

INSTALLATION INSTRUCTIONS

HEAVY INDUSTRY GRIPS, ELECTRONIC THROTTLE, CHROME

6122

THANK YOU FOR CHOOSING KURYAKYN!

Protect yourself and others from possible injury and property damage or loss. Pay close attention to all instructions, warnings, cautions, and notices regarding the installation, use, and care of this product.

WARNING THIS INDICATION ALERTS YOU TO THE FACT THAT IGNORING THE CONTENTS DESCRIBED HEREIN CAN RESULT IN POTENTIAL DEATH OR SERIOUS INJURY.

CAUTION THIS INDICATION ALERTS YOU TO THE FACT THAT IGNORING THE CONTENTS DESCRIBED HEREIN CAN RESULT IN MINOR OR MODERATE POTENTIAL INJURY.

NOTICE THIS INDICATION ALERTS YOU TO THE FACT THAT IGNORING THE CONTENTS DESCRIBED HEREIN MAY NEGATIVELY AFFECT PRODUCT PERFORMANCE AND FUNCTIONALITY OR DAMAGE THE PRODUCT ITSELF OR THE PRODUCT TO WHICH IT IS BEING ATTACHED.

ENSURE THAT THE FOLLOWING PARTS HAVE BEEN INCLUDED IN THE KIT:

- 1 Clutch Side Grip
- 1 Throttle Side Grip for Electronic Throttle
- 1 Tube of Adhesive

YOU WILL ALSO NEED:

Set of Torx Wrenches, Set of Hex Wrenches, Utility Knife, 80-100 Grit Sandpaper, Adhesive Solvent.

NOTICE

THESE INSTALLATION INSTRUCTIONS CONTAIN IMPORTANT INFORMATION. ENSURE THE END USER RECEIVES THIS COPY AND IS AWARE OF ITS IMPORTANCE FOR FUTURE USE.

THROTTLE SIDE PROCEDURE

STEP 1 Read and understand all steps in the instructions before starting the installation. Park the motorcycle on a hard, level surface and turn off the ignition. Let motorcycle cool.

WARNING A FACTORY SERVICE MANUAL WILL BE HELPFUL IN PERFORMING THIS INSTALLATION. DO NOT ATTEMPT TO PERFORM THIS INSTALLATION IF YOU ARE NOT CONFIDENT IN YOUR ABILITY TO COMPLETE ALL OF THE STEPS IN THE PROCEDURE; CONSULT A TRAINED TECHNICIAN. IMPROPER INSTALLATION COULD RESULT IN SERIOUS INJURY OR DEATH.

NOTE: Refer to your service manual for additional information on the following Steps.

STEP 2 Separate the switch housings by removing the two Torx screws; set them aside, they will be re-used. You may also have to loosen the screws on the brake clamp to separate the switch housing halves.

STEP 3 With the switch housings separated, slide the stock handgrip assembly off the handlebars. This will not be re-used.

STEP 4 Refer to FIG 1. Slide on the new grip assembly in the desired orientation making sure the teeth on the inside of the grip assembly are positively engaged in the teeth of the sensor, and the flange is seated inside the switch housing.

STEP 5 Reassemble the switch housings using the two Torx screws that were removed in STEP 2. Tighten the screws on the brake clamp if they were loosened.

WARNING ROTATE THROTTLE AND CHECK THAT IT MOVES FREELY AND RETURNS TO CLOSED BEFORE STARTING BIKE. FAILURE TO PROPERLY ADJUST THE THROTTLE CABLES COULD RESULT IN LOSS OF CONTROL CAUSING SERIOUS INJURY OR DEATH.

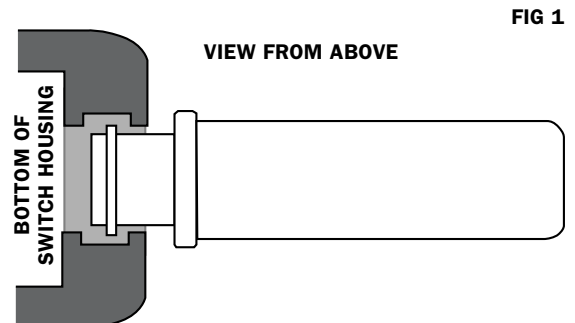

INSTALLATION INSTRUCTIONS

HEAVY INDUSTRY GRIPS, ELECTRONIC THROTTLE, CHROME

6122

-CONTINUED-

NOTICE

IT IS THE INSTALLER'S RESPONSIBILITY TO ENSURE THAT ALL OF THE FASTENERS (INCLUDING PRE-ASSEMBLED) ARE TIGHTENED BEFORE OPERATION OF THE MOTORCYCLE. KURYAKYN WILL NOT PROVIDE WARRANTY COVERAGE ON PRODUCTS OR COMPONENTS LOST DUE TO IMPROPER INSTALLATION OR LACK OF MAINTENANCE. PERIODIC INSPECTION AND MAINTENANCE ARE REQUIRED ON ALL FASTENERS.

CLUTCH SIDE PROCEDURE

CAUTION

USE EXTREME CARE WHEN USING THE GLUE INCLUDED WITH THIS KIT. READ ALL PRECAUTIONS AND AVOID CONTACT WITH SKIN OR EYES.

NOTICE

COVER ANY AREA OF THE MOTORCYCLE WHERE THE GLUE COULD POSSIBLY DRIP DURING INSTALLATION.

NOTE: Refer to your service manual for additional information on the following Steps.

STEP 1 Separate the switch housings by removing the two Torx or Hex screws depending on the year of your motorcycle); set them aside, they will be re-used. You may also have to loosen the clutch control clamp to allow the switch halves to separate.

STEP 2 Remove the clutch side grip. A sharp knife may be used to cut the grip lengthwise allowing you to "peel" the stock grip from the handlebar.

STEP 3 Sand the clutch side handlebar surface with 80-100 grit sandpaper or emery cloth to remove any previous glue or rubber residue. This provides a pristine metal surface for the new adhesive and the roughness provides the adhesive a better surface to adhere to.

STEP 4 With an ammonia based cleaner or similar degreasing agent and a clean rag, wipe off the exposed handlebar and the inside of the grip to remove any contaminants. Take the supplied tube of adhesive and squeeze a good amount of glue onto the inner side walls of the clutch grip. Rotating the grip while applying the glue will help distribute it evenly. Make sure you get the glue all the way to the end of the rubber insert in the grip.

STEP 5 Refer to FIG 2. In one smooth motion, slide the grip onto the handlebar and into position. Rotate it back and forth slightly as you slide it on to help distribute the glue evenly and keep the grip from "plowing" the glue up against the switch housing. Be sure to line up the new grip to match the throttle side. You must work quickly to get the desired position before the glue dries. (Approx. 6 seconds)

NOTICE

THE ADHESIVE SUPPLIED SETS UP ALMOST INSTANTLY IN THE ABSENCE OF AIR. THERE IS ENOUGH TIME TO SLIDE THE GRIP INTO PLACE, BUT ONCE IT STOPS MOVING, IT CANNOT BE ADJUSTED.

STEP 6 Once in place, squeeze the grip firmly to press the rubber against the bar and hold for 15 seconds. Allow at least 30 minutes to cure before operating the motorcycle. **ENSURE PROPER OPERATION AND CLEARANCE BEFORE OPERATING THE MOTORCYCLE.**

STEP 7 Re-assemble the switch housing halves and secure them with the screws removed in Step 1. Tighten the clutch control clamp if it was loosened in Step 1.

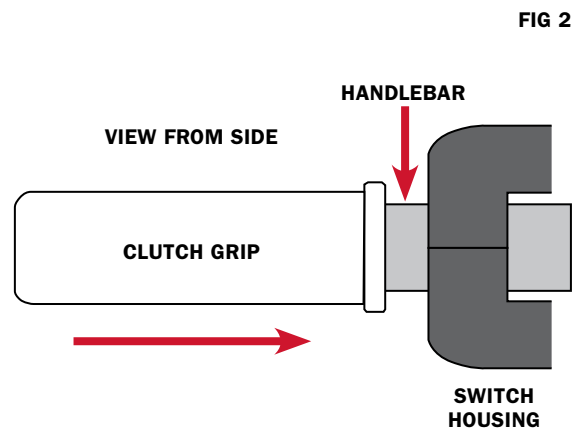



INSTALLATION INSTRUCTIONS

HEAVY INDUSTRY GRIPS, ELECTRONIC THROTTLE, CHROME

6122

-CONTINUED-

NOTICE

IT IS THE INSTALLER'S RESPONSIBILITY TO ENSURE THAT ALL OF THE FASTENERS (INCLUDING PRE-ASSEMBLED) ARE TIGHTENED BEFORE OPERATION OF THE MOTORCYCLE. KURYAKYN WILL NOT PROVIDE WARRANTY COVERAGE ON PRODUCTS OR COMPONENTS LOST DUE TO IMPROPER INSTALLATION OR LACK OF MAINTENANCE. PERIODIC INSPECTION AND MAINTENANCE ARE REQUIRED ON ALL FASTENERS.
