



STILETTO FOOTPEGS

4476

PARTS INCLUDED

- 1 Left Stiletto Peg without Adapter
- 1 Right Stiletto Peg without Adapter
- 1 Installation Instructions

Please read and understand entire instructions before starting installation.

THANK YOU FOR CHOOSING KÜRYAKYN!

IN ORDER TO PROTECT YOU AND OTHERS FROM POSSIBLE INJURY AND/OR PROPERTY DAMAGE OR LOSS, PLEASE PAY CLOSE ATTENTION TO ALL INSTRUCTIONS, WARNINGS, CAUTIONS AND NOTICES REGARDING THE USE AND CARE OF THIS PRODUCT.

WARNING

THIS INDICATION ALERTS YOU TO THE FACT THAT IGNORING THE CONTENTS DESCRIBED HEREIN CAN RESULT IN POTENTIAL DEATH OR SERIOUS INJURY.

NOTICE

This indication alerts you to the fact that ignoring the contents described herein may negatively affect product performance and functionality.

NOTICE

IF INSTALLING THIS PRODUCT FOR ANOTHER PARTY, PLEASE MAKE SURE THEY RECEIVE THIS COPY OF THE INSTALLATION INSTRUCTIONS SO THEY ARE AWARE OF THE IMPORTANT INFORMATION CONTAINED IN THEM.

TOOLS SUGGESTED

Set of Combination Wrenches, Set of Hex Wrenches

STRICTLY OBSERVE THE FOLLOWING GUIDELINES IN ORDER TO USE THE PRODUCT PROPERLY AND AVOID POTENTIALLY DANGEROUS ACCIDENTS.

STEP 1 Read and understand all steps in the instructions before starting the installation. Park the motorcycle on a hard, level surface and turn off the ignition. Let cool.

NOTE: These pegs require the separate purchase of the appropriate Kuryakyn footpeg adapter for your model.

NOTE: Optional domed end caps are available to replace the pointed end caps. (Sold separately)

WARNING

YOU WILL BE WORKING AROUND THE ENGINE AND EXHAUST SYSTEM DURING INSTALLATION. ENSURE THAT THE ENGINE AND EXHAUST SYSTEM HAVE FULLY COOLED TO PREVENT INJURY.

WARNING

A FACTORY SERVICE MANUAL WILL BE HELPFUL IN PERFORMING THIS INSTALLATION. DO NOT ATTEMPT TO PERFORM THIS INSTALLATION IF YOU ARE NOT CONFIDENT IN YOUR ABILITY TO COMPLETE ALL OF THE STEPS IN THE PROCEDURE; CONSULT A TRAINED TECHNICIAN. IMPROPER INSTALLATION COULD RESULT IN SERIOUS INJURY OR DEATH.

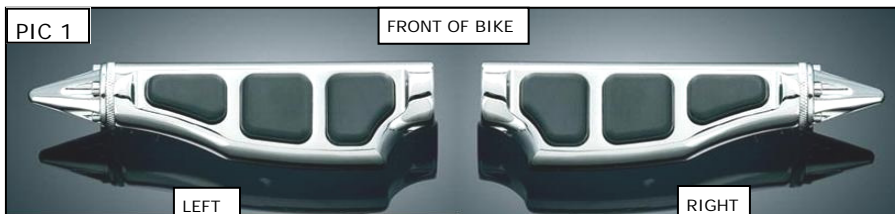

STEP 2 Remove the stock peg from the clevis. Pay attention to any spacers or washers installed between the male mount and the clevis, it may be helpful later. Set this hardware aside, it may be reused.

NOTE: PIC 1 shows the correct orientation of the left and right (sitting on bike) peg.

STEP 3 Install the new peg adapters as per the instructions with the peg adapters. Check that the peg adapters are installed correctly and able to fold upward.

WARNING FOOTPEGS MUST BE INSTALLED SO THEY WILL FOLD UPWARD AND REARWARD IF HIT BY ANY OBJECT. FAILURE TO ADJUST THE FOOTPEGS TO OPERATE IN THIS MANNER COULD RESULT IN SERIOUS INJURY OR DEATH.

WARNING YOU MUST COMPLETE THE FOLLOWING STEPS. IT IS IMPERATIVE THE 5/16"–18 X 2" SOCKET HEAD CAP SCREWS (FIG 1-D) ARE TIGHTENED SECURELY SO THE PEGS CANNOT ROTATE OR FALL OFF DURING WHILE IN USE. FAILURE TO DO SO COULD RESULT IN SERIOUS INJURY OR DEATH.

ATTACHING OR ADJUSTING THE POSITION OF THE FOOTPEG:

STEP 4 With a hex wrench, remove the #5–40 x 3/8" socket head cap screws, FIG 1-A, pointed end cap, FIG 1-B, and knurled trim ring, FIG 1-C from one of the Stiletto Pegs. Remove the end rubber from the peg body, FIG 1-F, to expose the 5/16"–18 x 2" socket head cap screw FIG 1-D.

STEP 5 Place the peg on the adapter in the desired position so the rider's or passenger's foot rests squarely on the rubber pads when seated on the motorcycle. With a long hex socket, thread the 5/16"–18 x 2" socket head cap screw to the adapter. With the peg in the correct position, securely tighten the 5/16"–18 x 2" socket head cap screw.

WARNING CHECK TO MAKE SURE THAT THERE IS PROPER GROUND CLEARANCE WHEN CORNERING. LOSS OF CONTROL OF THE MOTORCYCLE AND SERIOUS INJURY MAY OCCUR IF THE FOOTPEG IS NOT POSITIONED PROPERLY. REPOSITION THE FOOTPEG IF NECESSARY SO THAT THERE IS ADEQUATE CORNERING CLEARANCE.

STEP 6 Reinstall end rubber, knurled trim ring, end cap, and the #5–40 x 3/8" socket head cap screws.

STEP 7 Repeat STEP 4 through STEP 6 for the other Peg.

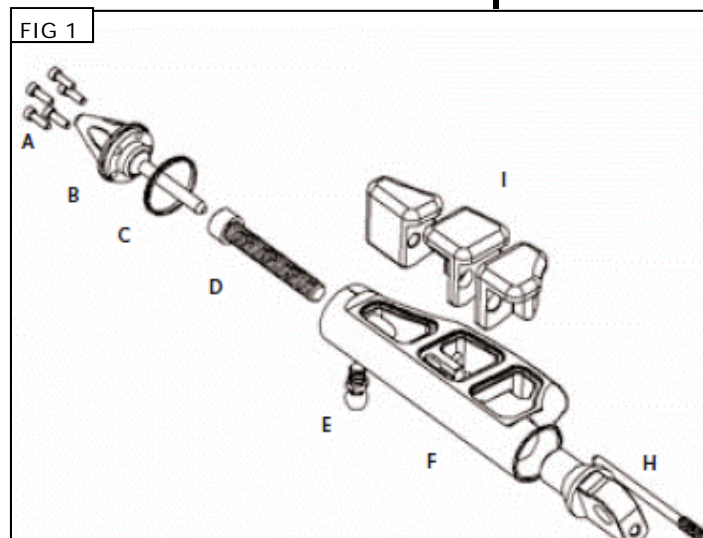

NOTICE It is the installer's responsibility to ensure that all of the fasteners (including pre-assembled) are tightened before operation of the motorcycle. Küryakyn will not provide warranty coverage on products or components lost due to improper installation or lack of maintenance. Periodic inspection and maintenance are required on all fasteners.