

PACK CONTENTS

1 x OS-BASE CRF 1100L
2 x M8 70mm bolts
2 x CRF Alloy Mounts
2 x 100mm bolt-on loops
2 x 75mm bolt-on loops
2 x side panel protective film
6 x M8 washers

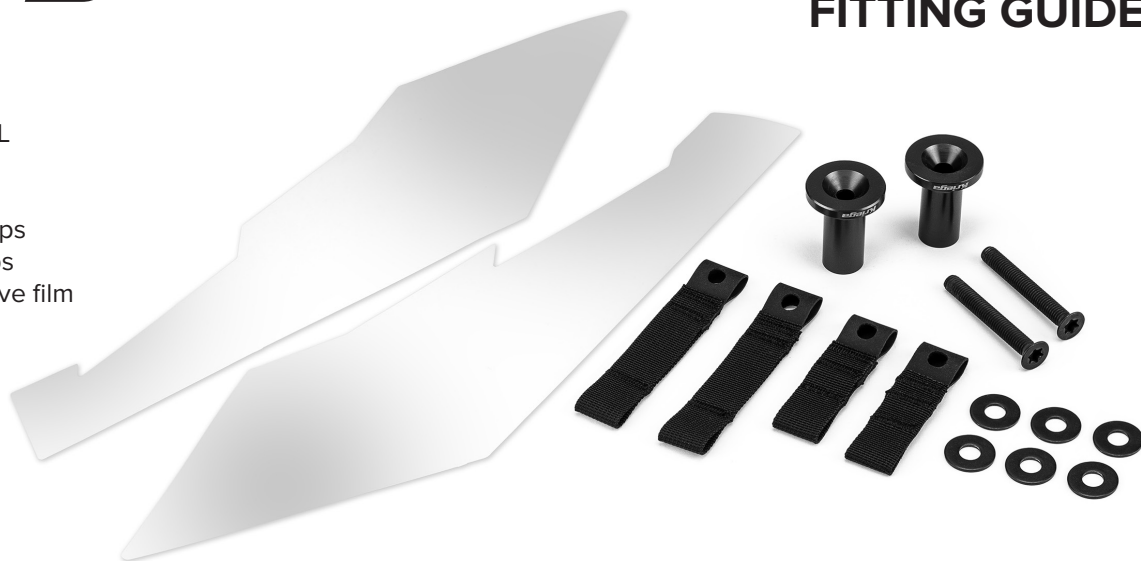

TOOLS REQUIRED

Torx driver T-40
10mm socket driver
Thread Lock

BEFORE YOU CAN FIT THE OS-BASE TO THE BIKE YOU WILL NEED TO MAKE SOME MINOR ADJUSTMENTS TO THE BIKE HARDWARE.

Remove the two rear Honda bolt hole covers and mount the Kriega CRF Alloy Mounts using the 70mm M8 bolts provided.

We recommend using thread lock on these bolts.

ALLOW THE THREAD LOCK TO CURE BEFORE USE (24hrs)

CENTRE PACK

The optional 75mm bolt-on loops and M8 washer should also be attached at this point if you wish to mount a centre pack (see back page for more details)

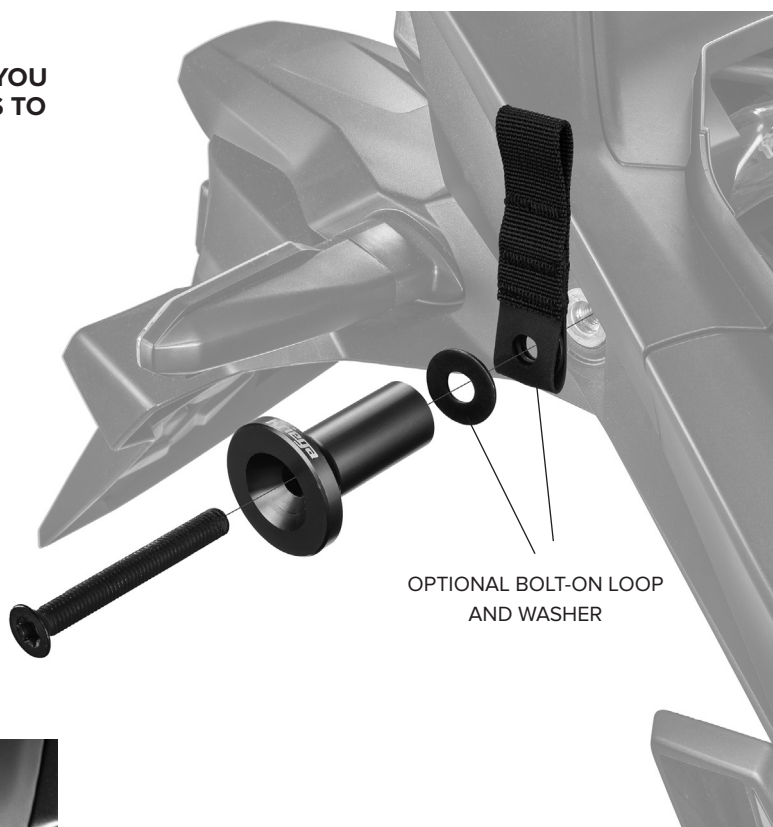

PROTECTIVE FILM

Apply the pre-cut panel protective film to the left and right rear side panels. To achieve good adhesion, clean the panels with a degreaser or methylated spirits before application.

Spray a solution of water and washing-up liquid onto the area to be fitted. Peel off the backing sheet avoiding touching the adhesive when dry, as this will leave a fingerprint in the film. Lay the film onto the panel and slide into position.

Once you are happy with the positioning use a squeegee to remove any fluid and air bubbles, this will secure the film into place. Finally, use a hair dryer or similar to warm up film to ensure adhesion especially around edges.

FIT A PAIR OF OS-ADV PACKS TO THE OS-BASE BEFORE INSTALLING THE COMPLETE SET-UP ON THE BIKE.

Choose a pair of OS-PACKS to meet your carrying capacity requirements:

- 2 x OS-6 = 12 litres
- 2 x OS-12 = 24 litres
- 2 x OS-18 = 36 litres

The modular system allows packs to be changed to a different size at a later date. There are also options to add an additional centre pack or mount one of the OS-PACKS as a stand alone pack for single day rides without the OS-BASE. (see back page for more details)



To fit an OS-PACK start by threading the roll-top quick release strap through the top loop. (see **fig A**)

Push the top 2 loops on the rear of the bag through the top 2 slots on the OS-BASE and hook-on the compression straps.

Push the bottom 2 loops on the rear of the bag through the corresponding 2 slots on the OS-BASE depending which size pack and hook-on the compression straps.

Then repeat on the other side. Once the OS-PACKS are connected, you have your SET-UP ready to fit onto the bike.

fig A



EXAMPLE OS-6 FITTING

MOUNTING OS-BASE SET-UP ON THE BIKE



1 Lay the OS-BASE over the motorcycle seat, forward from the final fitting position. Pass the front hook strap around the bike frame and attach the hook to the web loop so the hook is pointing down. Repeat on the other side.



2 Set the top straps to the longest length and loop over the alloy mounts on each side.



3 Standing at the rear of the bike hold both loose strap ends and pull until the OS-BASE is firmly mounted on the seat. A strong tap downwards on each OS-PACK will help the OS-BASE slide further onto the seat.



4 Once the OS-BASE is tight, fold over the loose strap ends and place them in the elastic loops.

You are ready to go.

To remove, simply loosen the straps and unhook, the complete set-up is off the bike in seconds.

MOUNTING A CENTRE PACK

The CRF BOLT-ON LOOPS included attach to the bike frame under the seat and fit behind the CRF alloy mounts to provide 4 hook-on points for a stand alone OS-PACK or US-Drypack.



Used in conjunction with the additional loops on the OS-BASE they provide various mounting locations for a 3 or more bag set-up.



To fit remove the rear seat and unscrew the two Honda seat strap bolts. Remove the seat strap but retain the 10mm bolts and washers. Slide an M8 washer inside the hypalon end of the two longer loops, then using the Honda bolts and washers fit to the seat strap mounting location.



Place an M8 washer inside of the hypalon end of the two shorter bolt-on loops. Add another M8 washer and mount behind the CRF Alloy Mounts as illustrated on the front page.

Replace the seat and you are ready to mount a centre pack without the need for a rack.

BODYWORK DAMAGE DISCLAIMER

Even though most of the OS-BASE mounts on the seat, the sides can rub against the plastic side panels of the bike, resulting in minor abrasion. This can be further exaggerated if mud and dust get in between the OS-BASE and the plastics. We have included pre-cut adhesive film with this kit to mitigate this issue as much as possible.

*It is the owner's responsibility to ensure the OS-BASE is attached in such a way that it does not damage or put at risk the owner or the property of the owner.
Do not exceed the UK legal speed limit.
This product has only been tested for up to UK road legal speeds.*

Kriega®

Learn more about motorcycle luggage systems and saddlebags on our website.