



• Thank you for purchasing the TNT-B meter for Yamaha Bolt®. Before installing, please read the instruction carefully and keep it for future reference.

⚠ Attention!

- For installation, please follow the steps described in manual. Any damage caused by wrong installation shall be imputed to the users.
- Don't break or modify the wire. To avoid the short circuit, please don't pull the wire when installing.
- Do not disassemble or change any parts excluding the manual description.
- The interior examination or maintenance should be executed by our professionals.

© MARK MEANING:

NOTE You could get the installation details from the information behind the mark.

⚠ Some processes must be followed to avoid the affection caused by wrong installation.

⚠ **WARNING!** Some processes must be followed to avoid damages to yourself or the public.

⚠ **CAUTION!** Some processes must be followed to avoid the damage to the vehicle.



FLASH



LIGHT ON



PRESS THE
BUTTON
ONCE



PRESS THE
BUTTON 3
SECONDS

1 Accessories

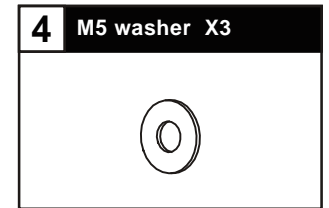
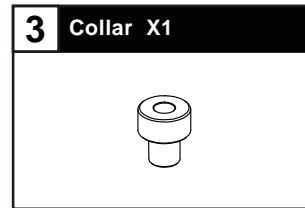
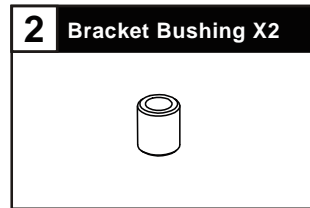
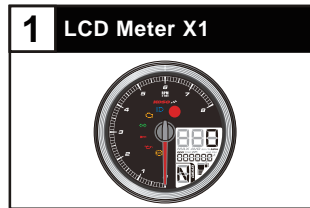

NOTE Contact your local distributor, if the items received in the box are not the same as the items listed above.

2-1 Installation description

Please proceed as follows

- 1 Bracket Bushing (Accessories 2)
- 2 Collar (Accessories 3)
- 3 LCD Meter (Accessories 1)
- 4 M5 washer (Accessories 4)
- 5 M5 nut (Accessories 5)

NOTE Please refer to the icon to disassemble. And install according to the reverse order of disassembly.

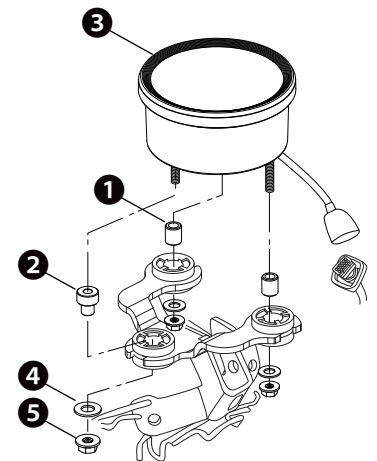
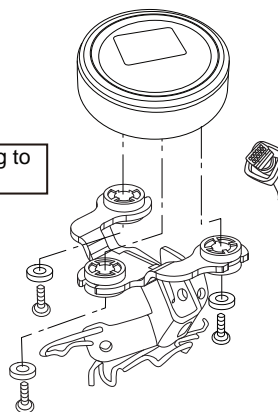
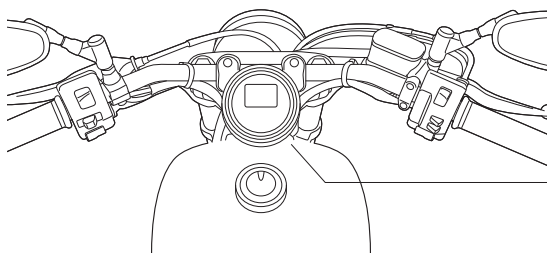

2-2 Installation description

Please proceed as follows

- 1 Bracket Bushing (Accessories 2)
- 2 Collar (Accessories 3)
- 3 LCD Meter (Accessories 1)
- 4 M5 washer (Accessories 4)
- 5 M5 nut (Accessories 5)

NOTE Please refer to the icon to disassemble. And install according to the reverse order of disassembly.

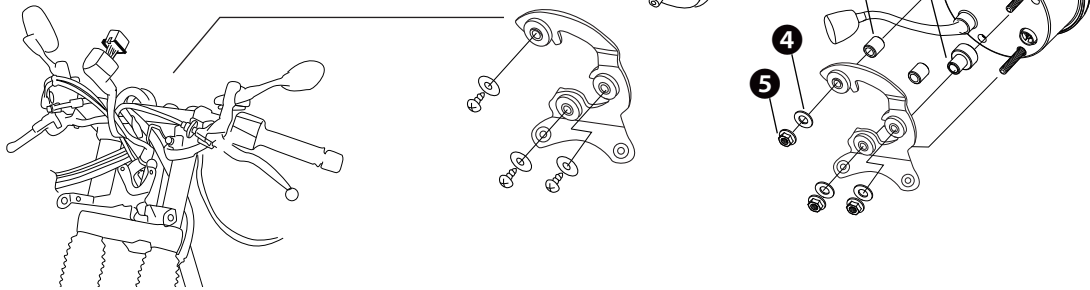

2-3 Wiring installation instructions

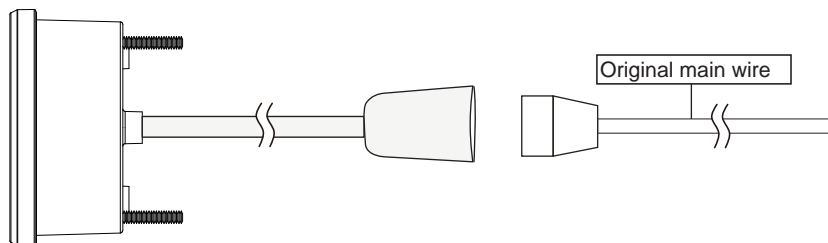

2-4 Actual wire installation precautions

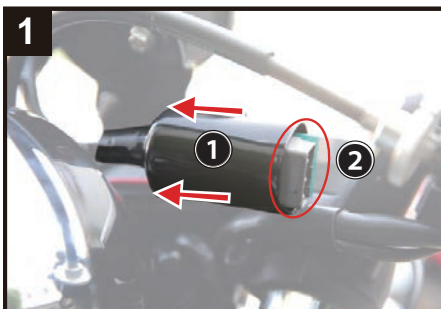

1. Push the waterproof cover of the KOSO BOLT Meter ① until the connector ② is exposed outside the cover.



2. ① plug the connector in with the vehicle main harness connector. ② The pull back the waterproof cover to fully cover the both connectors & vehicle main harness connector).

NOTE waterproof cover from KOSO BOLT Meter needs to be overlapped with vehicle main harness rubber connector cover.



3. Wrap up insulation tape on waterproof cover, wiring PVC pipe and the gap between the waterproof cover and original waterproof cover, as shown in the red circled part.

3-1 Basic function instruction

Tachometer
● Display range : 0 ~ 8,000 RPM

Indicator
● Round ● Turn signal ● ABS
● High beam ● Immobilizer system
● Engine Check ● Oil

Gear meter
● Display range : off, highest gear, N and highest gear, show all (N / 1 ~ 5)

Fuel Level
● Display range : ON / OFF / Flash

Odometer
● Display range : 000000 ~ 999999 km (miles) returns to zero upon exceed
● Setting unit : 1 km (mile)

Trip meter A/B
● Display range : 0000.0 ~ 9999.9 km (miles) returns to zero upon exceed
● Setting unit : 0.1 km (mile)

Fuel reserve tripmeter (TRIP-F)
● Display range : 0000.0 ~ 9999.9 km (miles) returns to zero upon exceed
● Display unit : 0.1 km (mile)

Max. speed record
● Display range : 0 ~ 360 km (0 ~ 255 miles)
● Display unit : 1 km (mile)

Speedometer
● Speedometer : 0~360 km (0~225 miles)
● Display unit : 1 km (mile)

Motor oil maintenance mileage
● Display range : User settings (500 ~ 16000 km / 300 ~ 10000 miles) ~ -999 km (miles), decrease according to the increase in total mileage
● Display unit : 1 km (mile)

Clock
● Display range : 12 / 24 hour format

Engine temp.
● Display range : -30 ~ 225 °C (-22 ~ 437 °F)

Voltmeter
● Display range : 8 ~ 18 V

Max. RPM
● Display range : 0 ~ 8,000 RPM
● Display unit : 100 RPM

Max. temperature record
● Display range : -30 ~ 225 °C (-22 ~ 437 °F)
● Display unit : 0.1 km (mile)

Max gear level record
● Display range : - (No display), N, 1 ~ 5 gear level
● Record gear level when at maximum RPM

3-2 Function, setting instructions

● Speedometer	Display range : 0 ~ 360 km (0 ~ 225 miles) Display unit : 1 km (mile)	○ Thermometer	Display unit : °C , °F , switchable
○ Display interval	Display range : <0.5sec	○ Engine temperature meter	Display range : -30 ~ 225°C (-22 ~ 437°F) Display unit : 1°C (°F)
○ Overspeed warning setting	Setting range : 30 ~ 360 km (19 ~ 225 miles) when above (including) setting value, warning light will light on Setting unit : 1 km (mile)	○ Display interval	Display range : <0.5 sec
○ Max. speed record	Display range : 0 ~ 360 km (0 ~ 225 miles)	○ Overheat warning setting	Setting range : 60 ~ 225°C (140 ~ 437°F) when above(including) setting value, warning light will lit.
○ Odometer	Display range : 0 ~ 999,999 km (miles) Display unit : 1 km (mile)	○ Max. temperature record	Setting unit : 1°C (°F)
○ Trip meter A/B	Display range : 0 ~ 9,999.9 km (miles) Display unit : 0.1 km (mile)	● Round indicator	Display range : -30 ~ 225°C (-22 ~ 437°F)
○ Motor oil maintenance	Setting range : Close / 500 ~ 16,000 km (300 ~ 10,000 miles) Setting unit : 100 km (miles)	○ Warning cause	speeding warning light, RPM shift light, over heat warning light, Low volt warning, Fuel warning, oil maintenance, Highest gear
○ Fuel reserve tripmeter	Display range : 0 ~ 9999.9 km (miles) Display unit : 0.1 km (mile)	○ Warning method	Lit. (L), Slow flash (S), Flash (F)
● Tire percentage	Setting range : 50 ~ 200% Setting unit : 1%	● Fuel meter	Display range : (ON) / (OFF) / Flash
● Gear meter	Display range : - (No display), N, 1 ~ 5 gear level	● Clock	Setting range : 12 / 24 hour format
○ Display interval	Display range : < 0.5 sec	● Under voltage warning	Setting range : 8.0 ~ 18.0 V Setting unit : 0.1V
○ Max. gear level record	Display range : - (No display), N, 1 ~ 5 gear level Record gear level when at maximum RPM	● Back light brightness	Setting range : 1 - 5 (darkest) ~ 5 - 5 (brightest) Setting unit : Each level represents 20%
● RPM	Display range : 0 ~ 8,000 RPM Display unit : 100 RPM	○ Back light color	Setting range : red, orange, yellow, green, blue, light blue, purple, white, loop switch
○ Display interval	Display range : <0.5 sec.	● Operating voltage	DC 12 V
○ Shift light warning setting	Setting range : 1,000 ~ 8,000 RPM when above (including) setting value, warning light will light on Setting unit : 100 RPM	○ Operating temperature	-10 + 60°C
○ Digital tachometer	Display range : 0 ~ 8,000 RPM Display unit : 100 RPM	○ Specification	JIS D 0203 S2
		○ Meter Size	94.7 x 94.7 x 69.2 mm
		○ Meter Weight	Around 217 g
		○ Indicator	Round (red light), High beam (blue light), Check Engine (yellow light), Turn signals (green light), Immobilizer system indicator light (red light), Oil (red light), ABS (yellow light)
		● ABS indicator setting	Setting range : Close (OFF) / Open (ON)

3-3 Main menu functions

● In the total mileage screen, press the **SELECT button once** to switch to Trip A screen. ◦

● When the engine switch is ON condition, hold the **SELECT button for 3 seconds** to enter settings.
(Please refer to video operation settings)

● Trip A screen, press the **SELECT button once** to switch to Trip B screen.

● Hold the **SELECT button for 3 seconds** to clear the Trip A recordings.

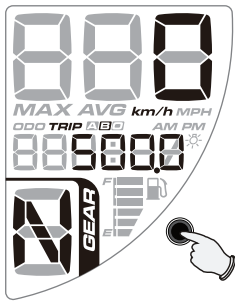

• Trip B screen, press the **SELECT** button **once** to switch to the mileage maintenance screen.

• Hold the **SELECT** button for 3 seconds to clear the Trip B recordings.

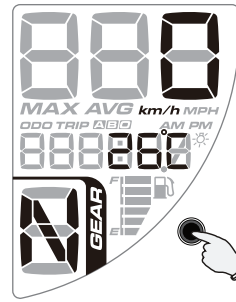

• In the temperature screen, press the **SELECT** button **once** to switch to the voltage screen.

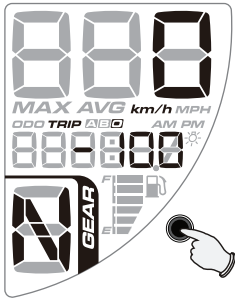

• In the mileage maintenance screen, press the **SELECT** button **once** to switch to the clock screen.

• Mileage maintenance will count down from setting value, when it reaches 0, the screen will blink to indicate the mileage reached.



• Hold the **SELECT** button for 8 seconds to clear the mileage maintenance recordings.



◦ In the 0 second, start holding the button.



◦ In the 3rd second, the inform feature will blink once.



◦ During 4 ~ 7 seconds, releasing the button will cancel the process.



◦ On the 8th second, the mileage maintenance record is cleared.

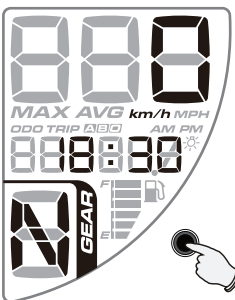

• In the clock screen, press the **SELECT** button **once** to switch to the temperature screen.

• Hold the **SELECT** button for 3 seconds to enter the time setting screen.

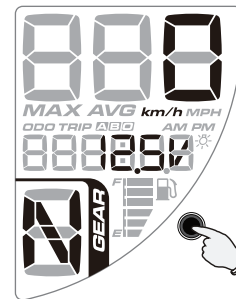

• In the voltage screen, press the **SELECT** button **once** to switch to the Max. Speed Record display screen.

• If fuel volume warning symbol is displayed, press the **SELECT** button to switch to fuel reserve screen.

P.S.

- When main switch is turned on, the fuel volume warning symbol will automatically switch to fuel reserved screen.
- When finished refuel, the fuel volume warning symbol will disappear. If do not clear out reserved fuel manually, it will automatically clear out the reserved fuel after driving a certain distance.
- In fuel reserved screen, press the **SELECT** button to switch to MAX record screen.
- Hold the **SELECT** button for 3 seconds to clear out fuel reserved records.

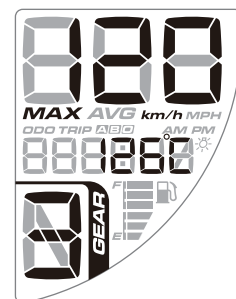

• In the Max. Speed record display screen, press the **SELECT** button **once** to return to total mileage screen.

• Hold the **SELECT** button for 3 seconds to clear the Max. Speed Record display.

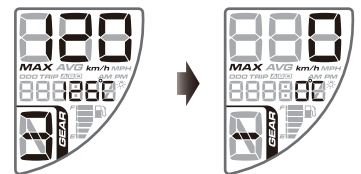

4-1 Setting screen operation settings

YAMAHA BOLT multifunction chronograph - setting screen operation setting

4-2 Tire percentage settings

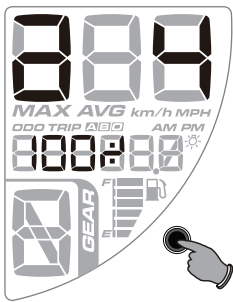

- In tire percentage screen, press and hold the **SELECT** button for 3 seconds to enter settings screen.
- Press the **SELECT** button to enter the gear learning setting screen.

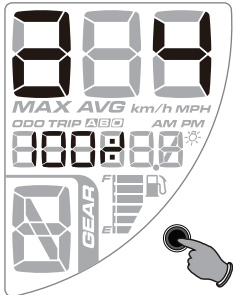

⚠ Please reset this setting value when you change a different size tire.

EX. The new tire circumference is 2180 mm. The calculation equation is as below.

The new tire circumference 2180 mm ÷ the original tire circumference 2080 mm X (100%) = The setting value (105%).

Press and hold the **SELECT** button for 3 seconds and release it until it move to the setting digital you want.



NOTE Cursor's order : hundred > ten > digit

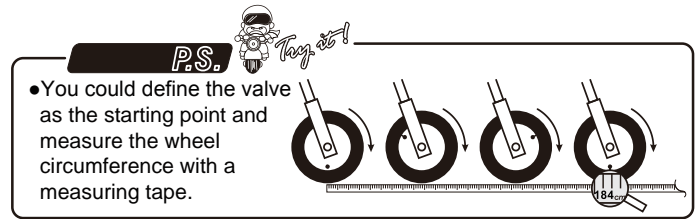

- You could define the valve as the starting point and measure the wheel circumference with a measuring tape.

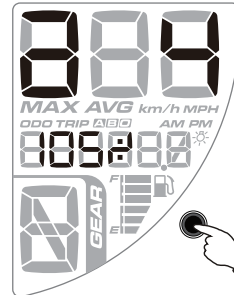

- Press the **SELECT** button to change the value.



- EX. The tire percentage setting is changed from 100 % to 105 %.

NOTE Setting range : 50 ~ 200 .



When switching gear or tire size, can adjust the tire percentage (%) parameter to calibrate speed.

1. When switching tire size

$$\text{Tire percentage (\%)} = \frac{2180}{2080} \times 100 = 105$$



Tire size from small to large

Standard



Tire size from large to small

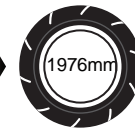

$$\text{Tire percentage (\%)} = \frac{1976}{2080} \times 100 = 95 \%$$

4-3 Gear level learning settings

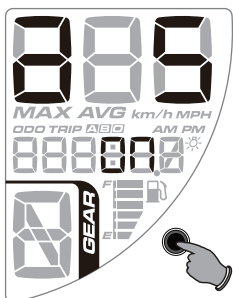

- In gear learning screen, press and hold the **SELECT** button for 3 seconds to enter settings screen.

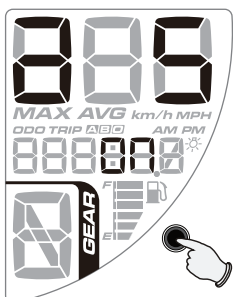

- Press the **SELECT** button once to choose turn on or off the gear indicator display.



NOTE If any changes happen to tires circumference then the gear indicator will need to re-learn the gear positioning.

NOTE Setting range : ON \ OFF .

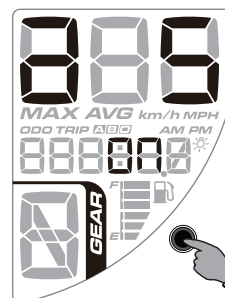

- When gear level display is "ON", hold the **SELECT** button for 3 seconds to enter gear level learning screen.
- When gear level display is "OFF", hold the **SELECT** button for 3 seconds to return to gear level learning setting screen.
- EX. Setting gear display from "OFF" to "ON".

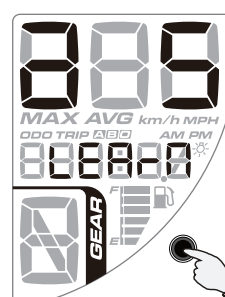

- EX. When chronograph display LEARN, it will blink.
- Press the **SELECT** button once to start the gear learning.

Note Press and hold the **SELECT** button for 3 seconds to quit the learning and return to the previous screen.

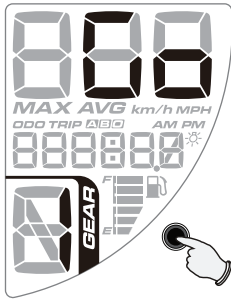

- Start the riding when "GO" is flashing.
- Press the **SELECT** button once to start the gear learning.

Note Press the **SELECT** button to quit the learning and return to the previous screen.

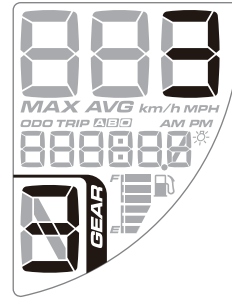

- When the number 3 is flashing, put the motorcycle in 3rd gear and start riding slowly until the meter detects the correct gear. Once the meter has detected 3rd gear, the screen will automatically switch to number 4.

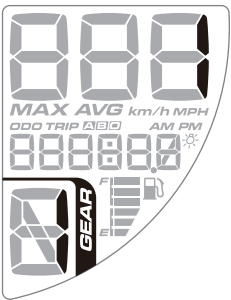

- When the number 1 is flashing, put the motorcycle in 1st gear and start riding slowly until the meter detects the correct gear. Once the meter has detected 1st gear, the screen will automatically switch to number 2.

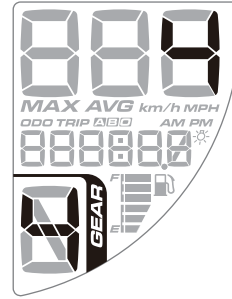

- When the number 4 is flashing, put the motorcycle in 4th gear and start riding slowly until the meter detects the correct gear. Once the meter has detected 4th gear, the screen will automatically switch to number 5.

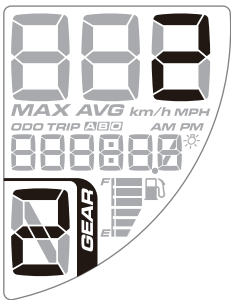

- When the number 2 is flashing, put the motorcycle in 2nd gear and start riding slowly until the meter detect the correct gear. Once the meter has detected the 2nd gear, the screen will automatically switch to number 3.

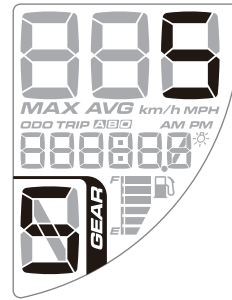

The main screen now displays the number 5, slow down and wait until the meter goes back to the main screen.

5 Troubleshooting

The following situation do not indicate malfunction of the meter. Please check the following points before taking it in for repair.

Trouble	Check item	Trouble	Check item
The meter doesn't work when the power is on.	<ul style="list-style-type: none"> • The power is not supplied properly to the meter. → Make sure the wiring harness is connected correctly. The wiring and fuse might be broken. → The battery is too old to supply enough DC 9V power to make the meter work. 	Speed, RPM or temperature does not display or displays error.	<ul style="list-style-type: none"> • Please confirm the wiring is properly connected. if displays error code, please refer to the original manual.
The meter shows wrong information.	<ul style="list-style-type: none"> • Please confirm wire is connected properly, if displays error code, please refer to the original manual. 	Fuel meter does not display or displays error.	<ul style="list-style-type: none"> • Please confirm the wiring is properly connected, if unable to display, please check if the vehicle fuel signal wire is broken.

※ If the problems still can't be solved, please contact your local distributor to get assistance.