



Thank you for purchasing KOSO's Harley Davidson Oil Temperature meter. Before operating this unit, please read the instructions thoroughly and retain them for future reference.

### ⚠ Notice

1. This meter only functions with DC 12V.
2. Any damages caused by faulty installation shall be imputed to the users.
3. To avoid a short circuit from occurring, do not pull or modify the wires during installation.
4. Dissassembling this unit will void your warranty. Maintenance and repairs should be executed by Professionals only.

### SYMBOL MEANING:

⚠ Some procedures must be followed in order to avoid faulty installation.

⚠ **WARNING!** Some procedures must be followed to avoid damages from occurring to yourself and others.

⚠ **CAUTION!** Some procedures must be followed to avoid damages from occurring to the vehicle.



FLASH



LIGHT ON



PRESS THE BUTTON ONE TIME



PRESS THE BUTTON 3 SECONDS

## 1 Accessories

### 1 LCD Meter X 1

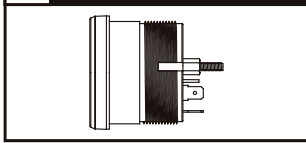

### 2 Power wire set X 1

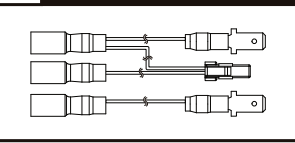

### 3 Sensor wire set X 1

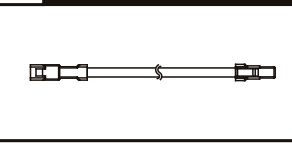

### 4 PT1/2 - 20UNF sensor X 1

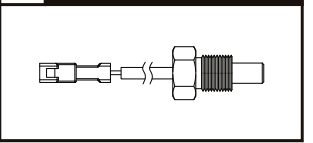

## 2-1 Gauge location

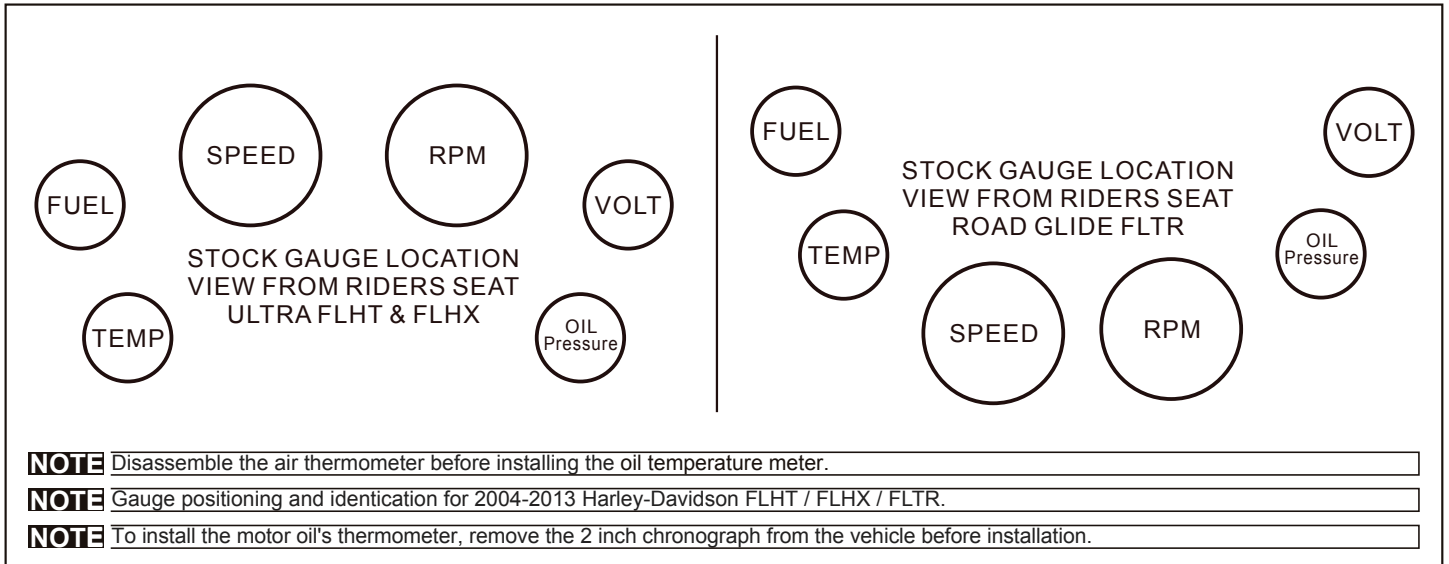

**NOTE** Disassemble the air thermometer before installing the oil temperature meter.

**NOTE** Gauge positioning and identification for 2004-2013 Harley-Davidson FLHT / FLHX / FLTR.

**NOTE** To install the motor oil's thermometer, remove the 2 inch chronograph from the vehicle before installation.

## 2-2 Disassembling Instructions



1. Disconnect the ground (-) (negative pole of the battery) from the vehicle's battery.



2. Remove the mounting screw and remove the fairing.

5. Remove the mounting hardware.



3. Disconnect the headlight connector.



6. Remove the meter from the inner fairing.



4. Disconnect the wiring from the speedometer, tachometer, ambient temp. meter, volt meter, fuel meter, and oil pressure meter.

7. Replace the meter with the new KOSO version.

**NOTE** The installation will be the same procedure backwards

## 2-3 Wiring Installation Instructions

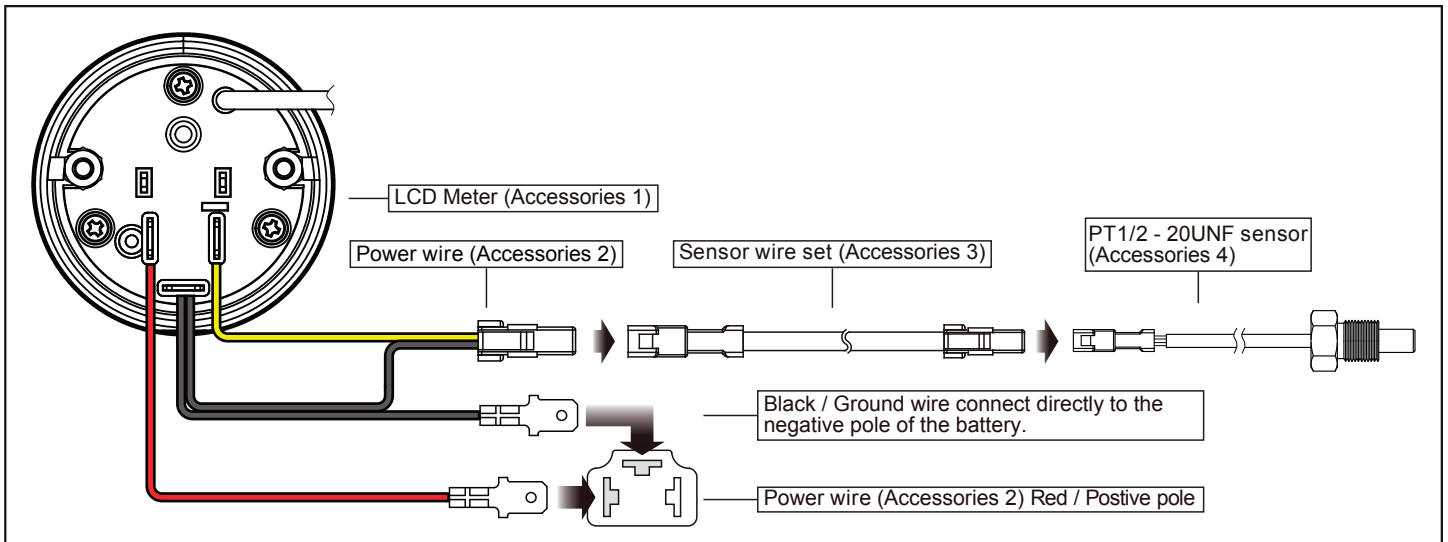

## 2-4 Installation Instructions

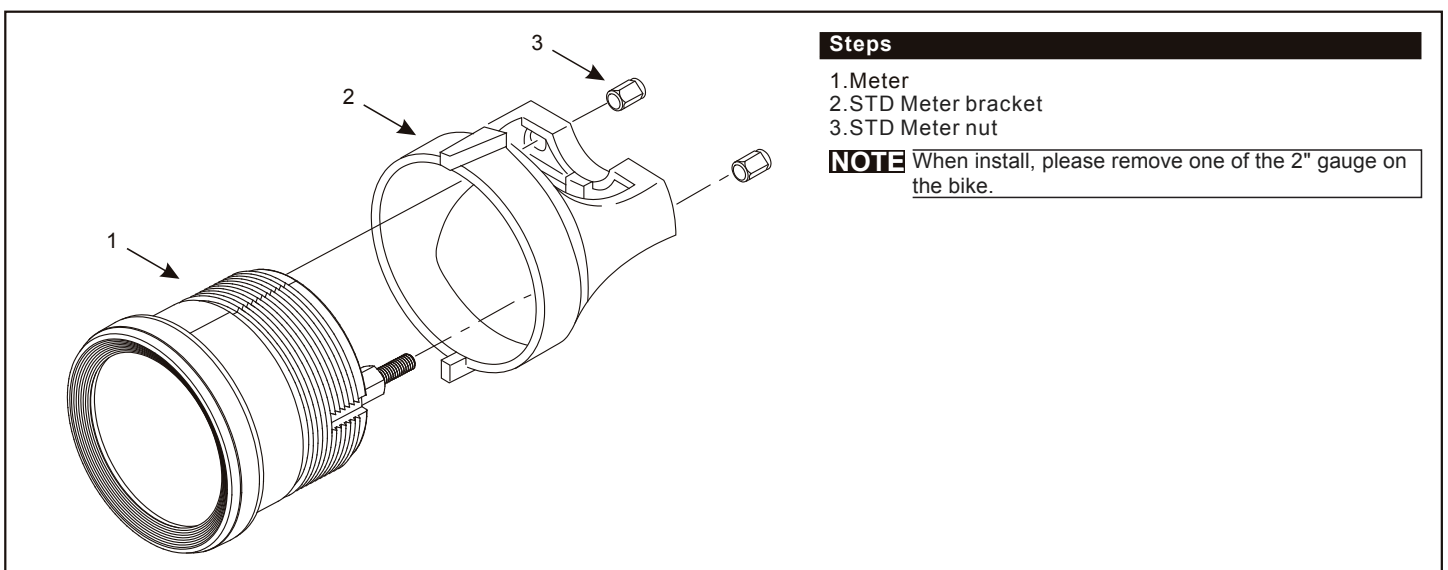

## 3-1 Overview

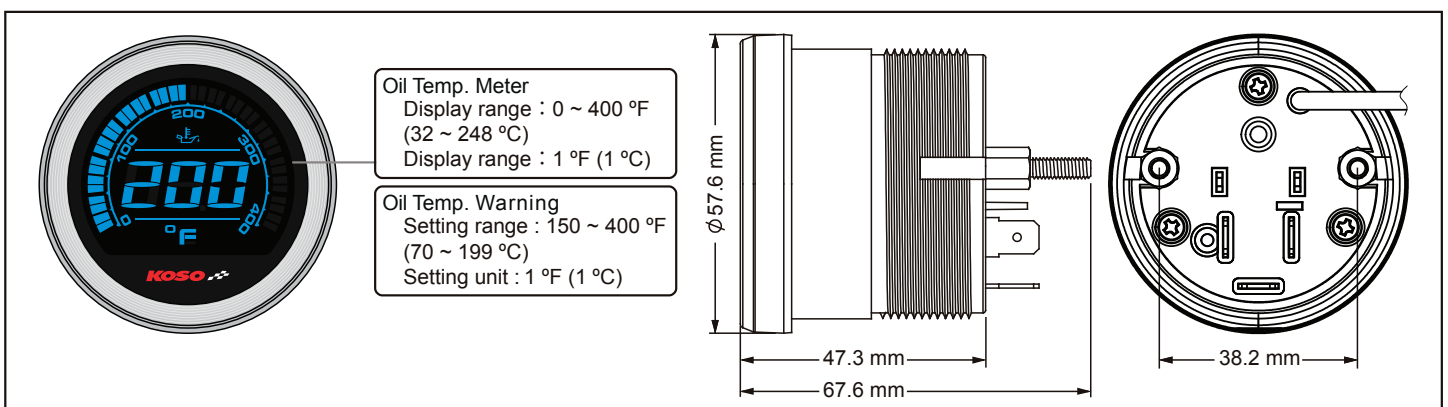

## 3-2 Function, setting instruction

Oil Temp. Meter	Display range : 0 ~ 400 °F (32 ~ 248 °C) Display unit : 1 °F (1 °C)	Backlight color	Setting range : Blue / Red
Oil Temp. warning	Setting range : 150 ~ 400 °F (70 ~ 199 °C) Setting unit : 1 °F (1 °C)	Backlight setting	Setting range : 1~5
Effective voltage	DC 12 V	Effective temperature range	-10 ~ 60 °C
		Meter standard	JIS D 0203
		Meter size	D57.5 X 47.3 mm
		Meter weight	86 g

**NOTE** Design and specifications are subject to change without notice!

**NOTE** Please be advised this meter was programmed according to original factory parameters. If the vehicle has been modified or customized and the parameters have been change, then the meter display might not be accurate

**NOTE** The backlight adjustment (brightness and color) must be done through the Speedometer housing with the communication harness.

## 4 Entering the settings

\* To enter the gauge settings mode, you must follow the steps below :

**A** : The key must be switched to ON/ACCESSORIES (1).

**B** : The Engine OFF/Run must be OFF (2).

**C** : The speedometer must be displaying ODOMETER (3).

**D** : Press and hold the Trip/Reset button down for 3 seconds to enter the settings (4).

**E** : Use the Trip/Reset button to navigate through the settings (4).

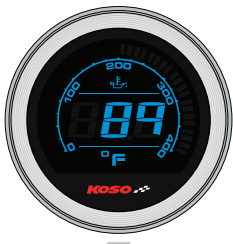
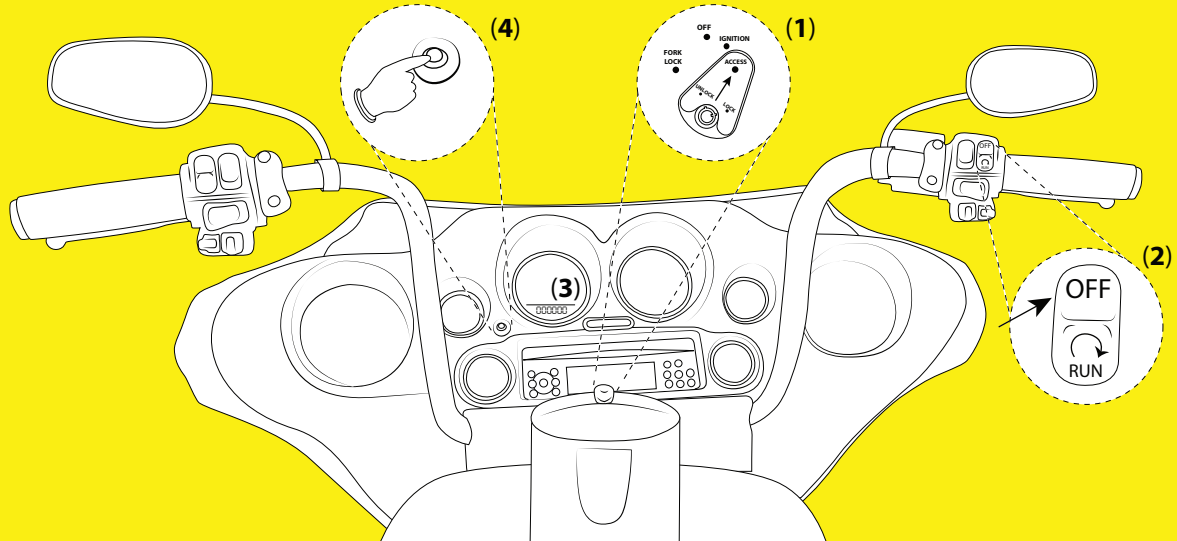

In the main screen, hold the **button for 3 seconds** to enter in the settings screen.

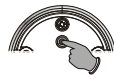

### 4-1 Temperature unit settings

EX. To change the setting to °C.  
Press the **button** to change the setting.

**NOTE** Default: °F

⚠ Now the default is flashing

**NOTE** Setting range: °F or °C



EX. To change the setting from °F to °C.  
Hold the **button for 3 seconds** to enter the Oil temp. warning setting screen.



### 4-2 Oil temp. warning settings

Press and hold the **button for 3 seconds** to move to the digit you want to set.



EX. Oil temp. warning is 212 °F.  
Press the button to change the setting.

⚠ Now the default is flashing.

**NOTE** Default : 212 °F

**NOTE** Setting range : 150 ~ 400 °F



EX. You want to set the oil temp. warning at 212 °F to 215 °F.

Press and hold the **button for 3 seconds** to enter the backlight color setting screen.



### 4-3 Backlight color settings

Press the button to change the setting.



EX. You want to set the backlight color at rE (Red).  
Press hold pressing the **button for 3 seconds** to enter the backlight setting screen.

**NOTE** Default : bu (Blue)

⚠ Now the default is flashing

**NOTE** Setting range : bu (Blue) and rE (Red)



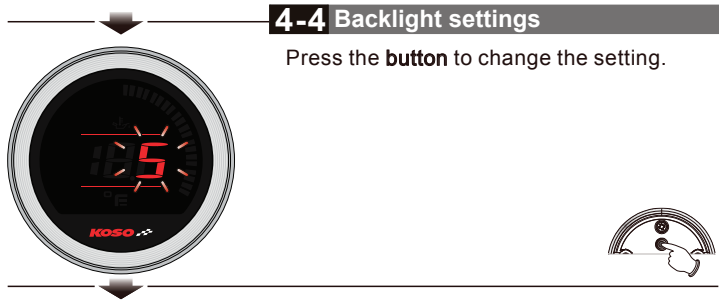

#### 4-4 Backlight settings

Press the **button** to change the setting.



EX. You want to set the backlight at 3 .  
Press and hold the **button for 3 seconds**  
to go back to the main screen.

**NOTE** Default : 5

⚠ Now the default is flashing

**NOTE** Setting range : 1 ~ 5

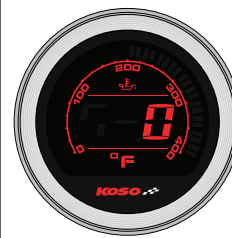

Main screen.

### 5 Oil temperature sensor

Remove the drain plug and replace it with the Koso oil temperature sensor (Item #4). Remove the O-ring from the drain plug and install it on the temperature sensor to avoid any oil leak. However, we do recommend that you install a new O-ring to ensure proper use.

Torque the Sensor at 1/4. Apply pressure of 10 to 12 ft lbs.

Once installation is complete, warm up the engine and verify that there is no oil leak before riding your bike.

### 6 Troubleshooting

The following situations do not indicate malfunction of the meter. Please check the following points, before taking it in for repairs.

Trouble	Check item
The meter doesn't work when the power is on.	If there is no power being supplied to the meter. Make sure the wires are connected and that the wires and fuse are not broken. The battery is broken or the battery is too old to supply enough power (DC 12V) to make the meter work.
Temp does not appear or appears incorrectly.	Check the sensor. Is the wire or temperature sensor broken?