



INSTALLATION INSTRUCTIONS

PART NUMBER: RK-3955

Congratulations, you have purchased the finest custom air cleaner that money can buy. With proper care, this filter will last 1 million miles or more. This custom air cleaner replaces the stock air cleaner assembly. The following procedure **MUST** be followed to ensure a proper fit and seal of the custom air cleaner.

TOOLS NEEDED:

5/32 allen key
3/16 allen key
1/4 allen key
5/16 allen key
t-27 torx
7/16 socket
ratchet

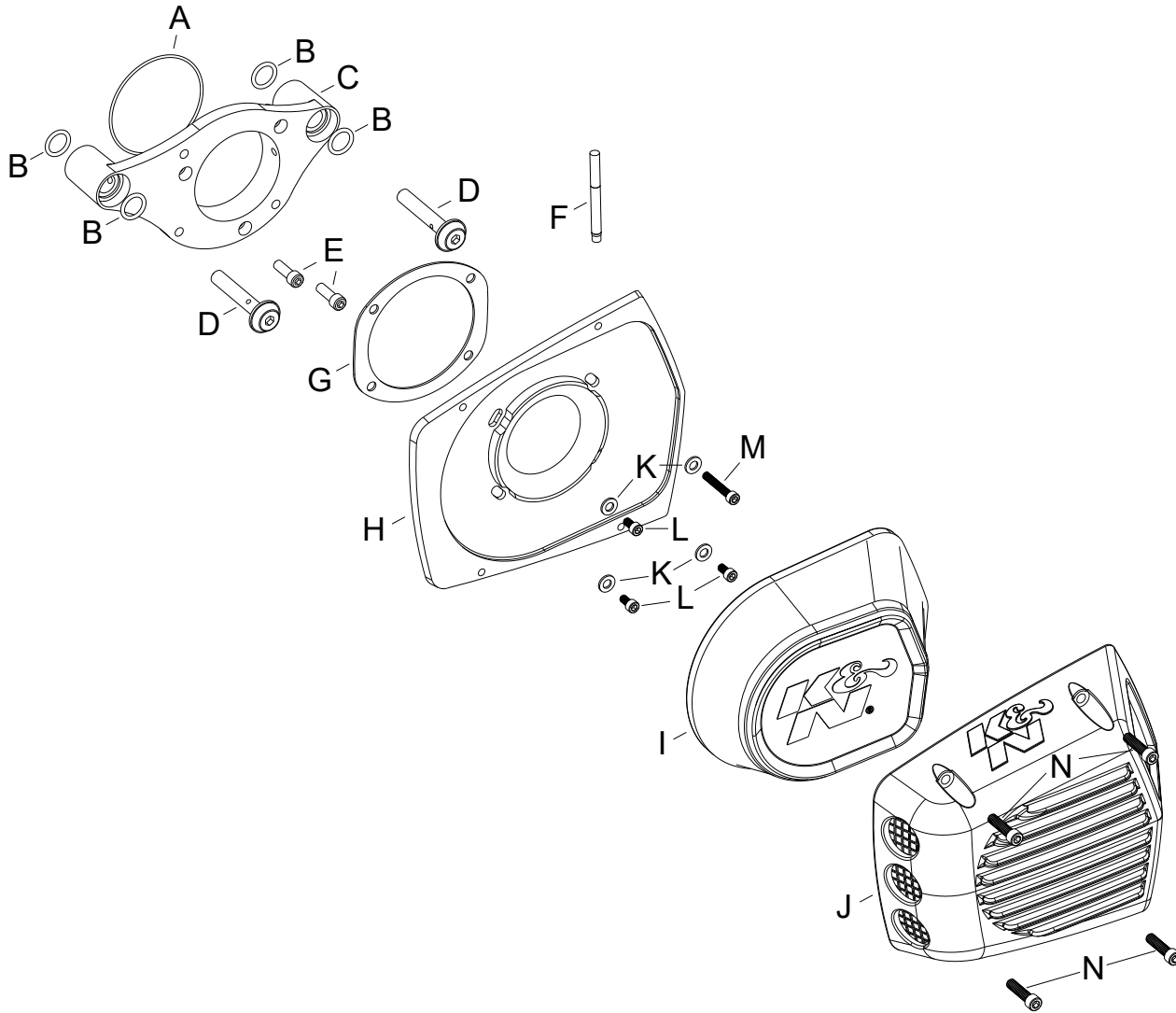

PARTS LIST:

Description	Qty.	Part #
A O-RING; 2.88"OD X 2.74"ID	1	09773
B O-RING; 9/16" ID, .10 THICK	4	07761
C BACK PLATE; HARLEY	1	63-1139-2B
D BREATHER BOLT	2	22243
E SCREW; 1/4-20 X 3/4" SOC.	2	07731
F THREAD LOCKER	1	482
G GASKET; 63-1134	1	63-1134-3
H AIR SCOOP BASE	1	RK-3950-2
I AIR FILTER	1	E-3987
J AIR SCOOP	1	RK-3950-1
K WASHER; FLAT M6 SS	4	1-3016
L SHCS 1/4-20 X 3/8"	3	22246
M SHCS 1/4-20 X 1 1/4"	1	22247
N SHCS 1/4-20 X 1"	4	077009

NOTE: FAILURE TO FOLLOW INSTALLATION INSTRUCTIONS AND NOT USING THE PROVIDED HARDWARE MAY DAMAGE THE INTAKE TUBE, THROTTLE BODY AND ENGINE.

TO START:

1. Turn off the ignition and disconnect the negative battery cable.



2. Remove air filter cover bolt and air filter cover as shown.



3. Loosen the three air filter retaining bolts as shown.



4. Remove the air filter from the vehicle and disconnect the crankcase breather tubes.



5. Remove the two breather/air filter base mounting bolts as shown.
NOTE: K&N Engineering, Inc. recommends that customers do not discard the factory air intake components.



6. Remove the air filter base from the vehicle as shown.
NOTE: K&N Engineering, Inc. recommends that customers do not discard the factory air intake components.



7. Install three of the O rings provided onto the back side of the K&N® back plate as shown.



8. Install the remaining two o rings onto the front of the back plate as shown.



9. Using the two provided crankcase breather bolts; install the back plate onto the vehicle. Do not tighten bolts at this time. Make sure O rings do not fall out during this operation. Install the two allen bolts and tighten all bolts at this time.

NOTE: Apply one drop of the provided thread locker onto the bolts.



10. Install the air scoop base gasket and base plate with the provided hardware. Slightly tighten at this time. Using the air filter cover clock the filter base in position then finish tightening filter base plate.

NOTE: Apply one drop of the provided thread locker onto the studs.



11. Install the K&N® air filter and filter cover with provided bolts.

NOTE: Apply one drop of thread locker onto provided bolts.

12. Reconnect the vehicle's negative battery cable. Double check to make sure everything is tight and properly positioned before starting the vehicle.

13. It will be necessary for all K&N® custom air cleaners to be checked periodically for realignment, clearance and tightening of all connections. Failure to follow the above instructions or proper maintenance may void warranty.

ROAD TESTING:

1. Start the engine with the transmission in neutral. Listen for air leaks or odd noises. For air leaks secure hoses and connections. For odd noises, find cause and repair before proceeding. This kit will function identically to the factory system except for being louder and much more responsive.

2. Test ride the vehicle. Listen for odd noises or rattles and fix as necessary.

3. If road test is fine, you can now enjoy the added power and performance from your kit.

4. K&N Engineering, Inc., requires cleaning the intake system's air filter element every 50,000 miles. When used in dusty or off-road environments, our filters will require cleaning more often. We recommend that you visually inspect your filter once every 25,000 miles to determine if the screen is still visible. When the screen is no longer visible some place on the filter element, it is time to clean it. To clean and re-oil, purchase our filter Recharger® service kit, part number 99-5050 or 99-5000 and follow the easy instructions.