



INSTALLATION INSTRUCTIONS

PART NUMBER: RK-3951

This Assembly Fits:

SEE CATALOG FOR CURRENT APPLICATIONS

Congratulations, you have purchased the finest custom air cleaner that money can buy. This custom air cleaner replaces the stock air cleaner assembly. The following procedure **MUST** be followed to ensure a proper fit and seal of the custom air cleaner.

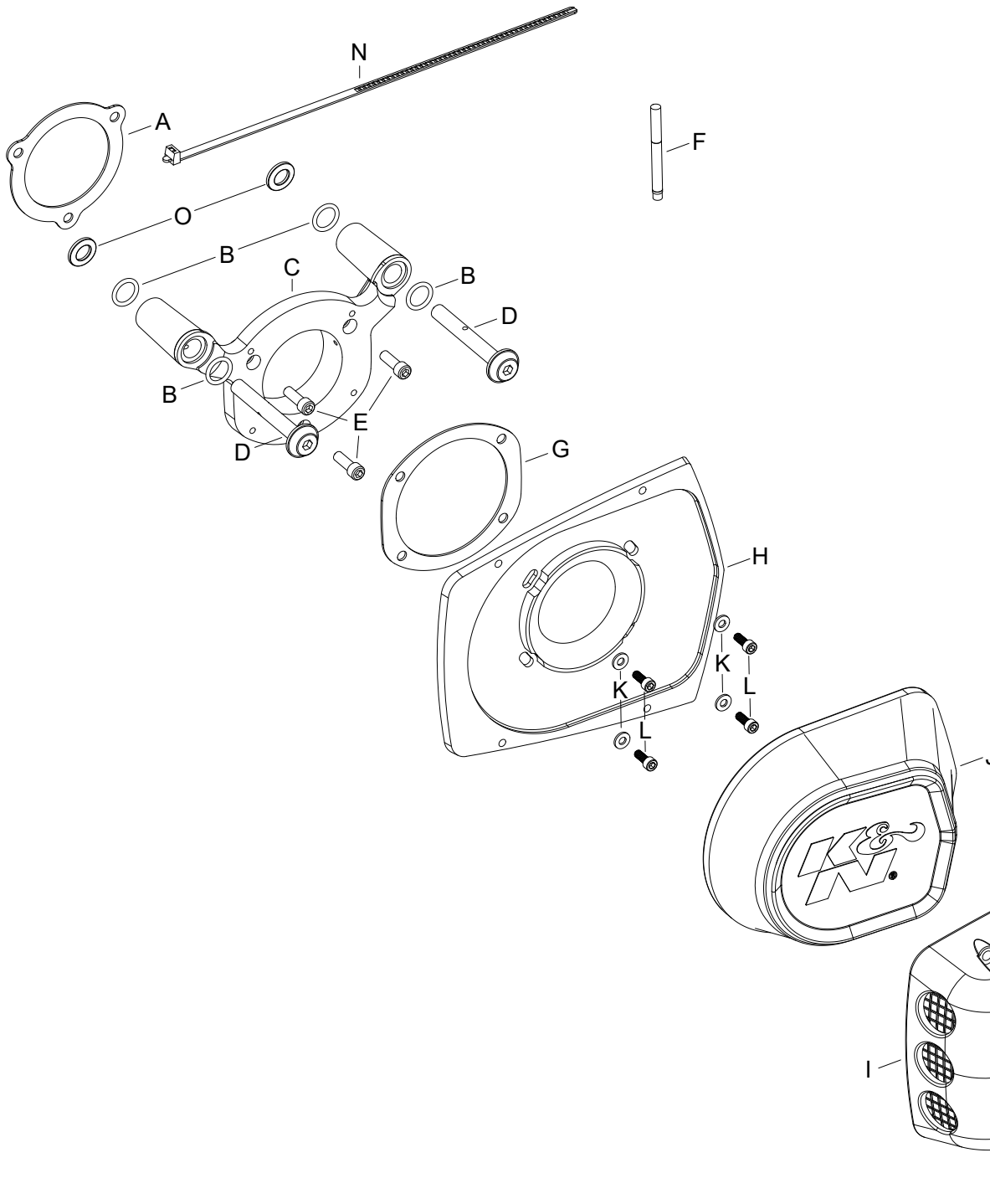

TOOLS NEEDED:

- 5/32 allen
- 3/16 allen
- 1/4 allen
- 5/16 allen
- t-27 torx
- 7/16 socket
- ratchet
- extension

PARTS LIST:

Description	Qty.	Part #
A GASKET; HARLEY DAVIDSON	1	09708
B O-RING; 9/16" ID, .10 THICK	4	07761
C BACK PLATE; HARLEY	1	63-1134-2B
D BREATHER BOLT	2	22248
E SCREW; 1/4-20 X 3/4" SOC.	3	07731
F THREAD LOCKER	1	482
G GASKET; 63-1134	1	63-1134-3
H AIR SCOOP BASE	1	RK-3950-2
I AIR SCOOP	1	RK-3950-1
J AIR FILTER	1	E-3987
K WASHER; FLAT #10 SS	4	08257
L SCREW: 10-32 X 1/2" SS SOC.	4	22240
M SCREW; 1/4-20 X 1" SS SOC.	4	077009
N CABLE TIE: 12"	1	22242
O SPACER	2	06536

NOTE: FAILURE TO FOLLOW INSTALLATION INSTRUCTIONS AND NOT USING THE PROVIDED HARDWARE MAY DAMAGE THE INTAKE TUBE, THROTTLE BODY AND ENGINE.

TO START:

1. Turn off the ignition and disconnect the negative battery cable.



2. Remove the air filter cover retaining bolt and then remove air filter cover as shown. Some models may have a number plate covering the bolts, if so firmly grip edge and remove.



3. Remove the three air filter retaining bolts as shown.



4. Remove the air filter with breather hoses as shown.



5. Remove the two crankcase bolts as shown.



6. Remove the air filter breather base as shown. **NOTE: K&N Engineering, Inc. recommends that customers do not discard the factory air intake components.**



7. Using the provided tie wrap, secure the loose pigtail to the throttle position switch wiring harness. Step 7 is not required on all models.



8. Install two o rings provided onto the back side of the K&N® back plate as shown.



9. Install the remaining two o rings onto the front of the back plate as shown.



10. Using the two provided crankcase breather bolts install the back plate onto the vehicle as shown. Do not tighten the breather bolts at this time.

NOTE: On applications that have had the support bracket removed, install the two provided spacers between the back plate and cylinder head at the breather holes and then install the breather bolts as shown



11. Install the provided gasket between the throttle body and back plate use the provided hardware to secure the back plate to the throttle housing. Tighten the crankcase breather bolts.

NOTE: Apply one drop of the provided thread locker onto the provided bolts.

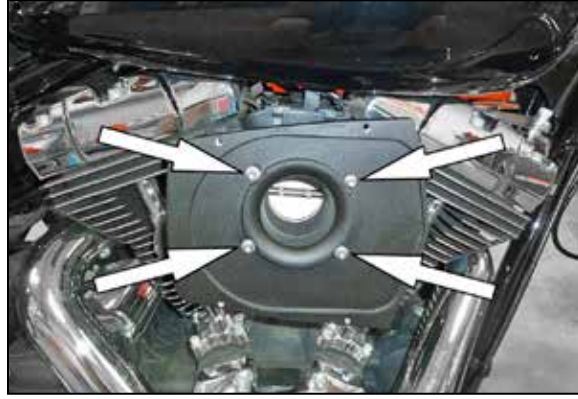

12. Install the provided gasket between the back plate and air filter base using provided hardware. Slightly tighten at this time. Using the air filter cover clock the filter base in position then finish tightening filter base plate.

NOTE: Apply one drop of thread locker onto provided bolts.



13. Install air filter and air filter cover with provided bolts.

NOTE: Apply one drop of thread locker onto provided bolts.

14. Reconnect the vehicle's negative battery cable. Double check to make sure everything is tight and properly positioned before starting the vehicle.

15. The C.A.R.B. exemption sticker, (attached), must be visible, so the emissions inspector can see it when the vehicle is required to be tested for emissions. California requires testing every two years, other states may vary.

16. It will be necessary for all K&N® custom air cleaners to be checked periodically for realignment, clearance and tightening of all connections. Failure to follow the above instructions or proper maintenance may void warranty.

ROAD TESTING:

1. Start the engine with the transmission in neutral. Listen for air leaks or odd noises. For air leaks secure hoses and connections. For odd noises, find cause and repair before proceeding. This kit will function identically to the factory system except for being louder and much more responsive.

2. Test ride the vehicle. Listen for odd noises or rattles and fix as necessary.

3. If road test is fine, you can now enjoy the added power and performance from your kit.

4. K&N Engineering, Inc., requires cleaning the intake system's air filter element every 50,000 miles. When used in dusty or off-road environments, our filters will require cleaning more often. We recommend that you visually inspect your filter once every 25,000 miles to determine if the screen is still visible. When the screen is no longer visible some place on the filter element, it is time to clean it. To clean and re-oil, purchase our filter Recharger® service kit, part number 99-5050 or 99-5000 and follow the easy instructions.