



# INSTALLATION INSTRUCTIONS

## PART NUMBER: RK-3947

This Assembly Fits:

**SEE CATALOG FOR CURRENT APPLICATIONS**

K&N are proud to offer a high quality product at the industries most competitive pricing!

Congratulations, you have purchased the finest custom air cleaner that money can buy. With proper care, this filter will last 1 million miles or more. This custom air cleaner replaces the stock air cleaner assembly. The following procedure **MUST** be followed to ensure a proper fit and seal of the custom air cleaner.

### TOOLS NEEDED:

ratchet  
extension  
7/16" socket  
5/16" hex key wrench  
3/32" hex key wrench  
t27 torx  
7/16" wrench

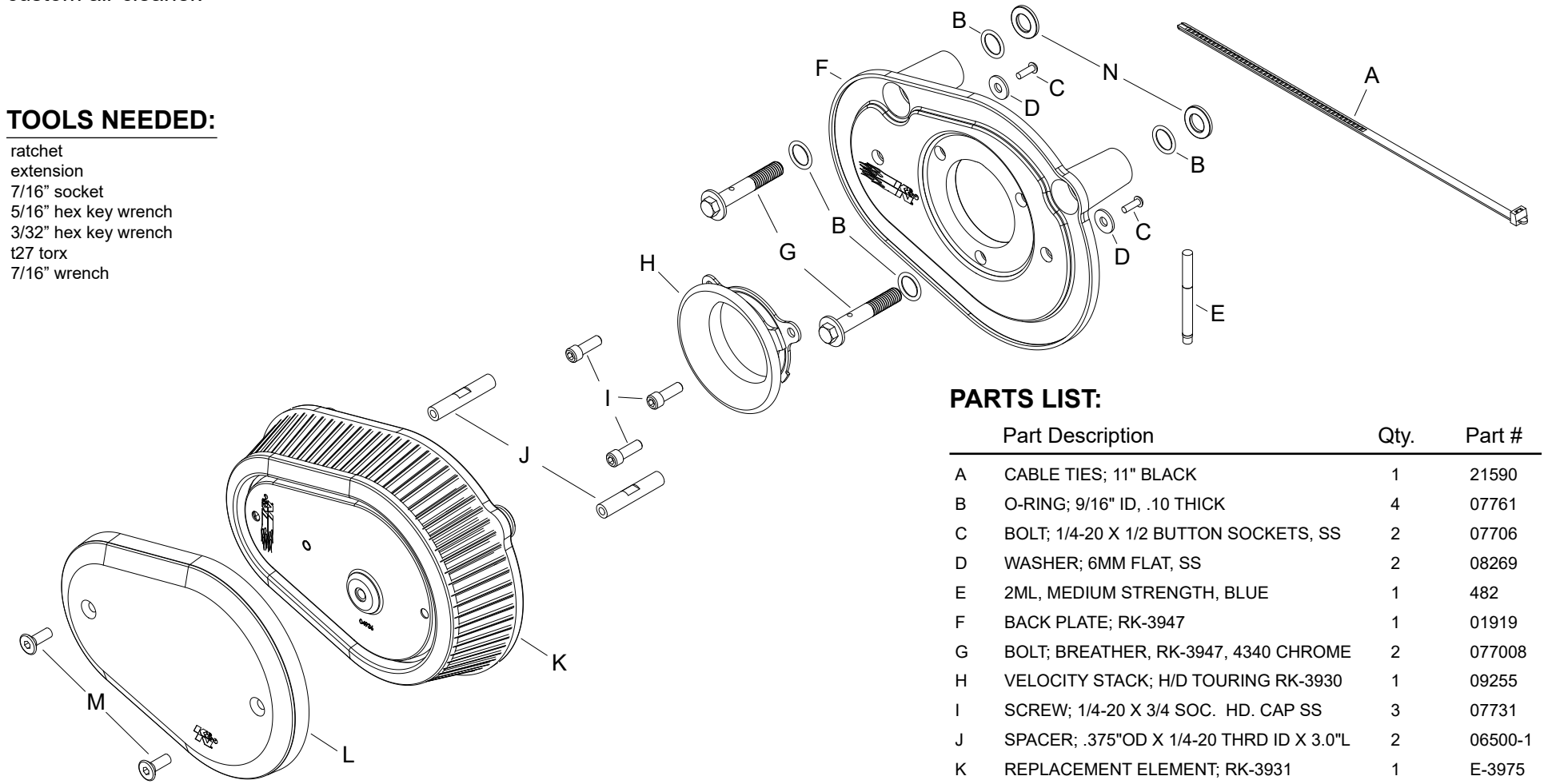

### PARTS LIST:

	Part Description	Qty.	Part #
A	CABLE TIES; 11" BLACK	1	21590
B	O-RING; 9/16" ID, .10 THICK	4	07761
C	BOLT; 1/4-20 X 1/2 BUTTON SOCKETS, SS	2	07706
D	WASHER; 6MM FLAT, SS	2	08269
E	2ML, MEDIUM STRENGTH, BLUE	1	482
F	BACK PLATE; RK-3947	1	01919
G	BOLT; BREATHER, RK-3947, 4340 CHROME	2	077008
H	VELOCITY STACK; H/D TOURING RK-3930	1	09255
I	SCREW; 1/4-20 X 3/4 SOC. HD. CAP SS	3	07731
J	SPACER; .375"OD X 1/4-20 THRD ID X 3.0"L	2	06500-1
K	REPLACEMENT ELEMENT; RK-3931	1	E-3975
L	TOP PLATE	1	01910
M	BOLT; 1/4-20 X 3/4 F/H/A, SS	2	22218
N	SPACER	2	06536

**NOTE: FAILURE TO FOLLOW INSTALLATION INSTRUCTIONS AND NOT USING THE PROVIDED HARDWARE MAY DAMAGE THE THROTTLE BODY AND ENGINE.**

### TO START:

1. Turn off the ignition and disconnect the negative battery cable.



2. Remove the bolt which secures the bonnet to the filter assembly and then remove the bonnet from the vehicle.

**NOTE: On some applications the engine cubic inch badge may cover the bolt, the badge is held on with Velcro. Peel the badge off to expose the bolt.**



3. Remove the three bolts which secure the air filter to the filter base and then remove the air filter along with the crank case breather tube and bonnet bracket.



4. Remove the two crank case breather bolts shown and then remove the air filter base from the throttle body.

**NOTE: Some models may have a wiring pigtail attached to the filter base. Unhook the wiring pig tail from the filter base. Using the provided tie wrap, secure the wiring pig tail to the throttle body wiring harness. On non US models, disconnect the intake valve solenoid.**

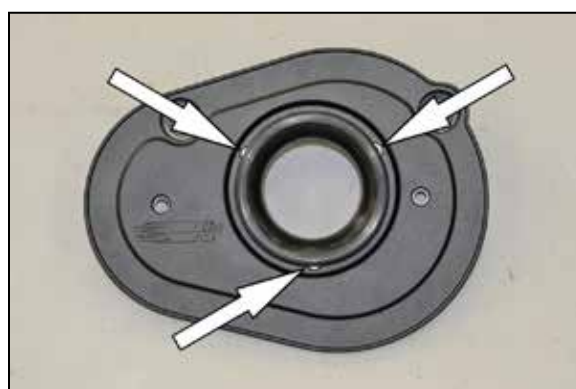

5. Install the provided venturi and the three throttle body mounting bolts into the back plate as shown. **NOTE: The bolts pass through the back plate and venturi on the back side.**



6. Install the two provided spacers onto the back plate as shown using the provided hardware. **NOTE: Place one drop of thread locker onto the threads of each bolt.**



7. Install two of the provided O-rings into the crank case breather plate as shown.



8. Install the back plate along with the two remaining O-rings, breather bolts, and throttle body mounting bolts as shown.

**NOTE: Be sure to place one drop of thread locker onto each bolt.**

**NOTE: On applications that have had the support bracket removed, install the two provided spacers between the back plate and cylinder head at the breather holes and then install the breather bolts as shown.**



9. Install the filter and top plate onto the back plate and secure with the provided hardware.

**NOTE: be sure to place one drop of thread locker to the mounting bolts.**



10. Double check to make sure everything is tight and properly positioned before starting the vehicle.

11. The C.A.R.B. exemption sticker, (attached), must be visible, so the emissions inspector can see it when the vehicle is required to be tested for emissions. California requires testing every two years, other states may vary.

12. It will be necessary for all K&N® high flow intake systems to be checked periodically for realignment, clearance and tightening of all connections. Failure to follow the above instructions or proper maintenance may void warranty.

#### ROAD TESTING:

1. Start the engine with the transmission in neutral or park. Listen for air leaks or odd noises. For air leaks secure hoses and connections. For odd noises, find cause and repair before proceeding. This kit will function identically to the factory system except for being louder and much more responsive.

2. Test drive the vehicle. Listen for odd noises or rattles and fix as necessary.

3. If road test is fine, you can now enjoy the added power and performance from your kit.

4. K&N Engineering, Inc., suggests checking the air filter element periodically for excessive dirt build-up. When the element becomes covered in dirt (or once a year), service it according to the instructions on the Recharger® service kit, part number 99-5050 or 99-5000.