



INSTALLATION INSTRUCTIONS

PART NUMBER: RK-3945

This Assembly Fits:

SEE CATALOG FOR CURRENT APPLICATIONS

Congratulations, you have purchased the finest custom air cleaner that money can buy. With proper care, this filter will last 1 million miles or more. This custom air cleaner replaces the stock air cleaner assembly. The following procedure **MUST** be followed to ensure a proper fit and seal of the custom air cleaner.

TOOLS NEEDED:

ratchet
extension
7/16" socket
t27 torx
3/32 allen key
5/16 allen key
7/16 wrench
7mm wrench

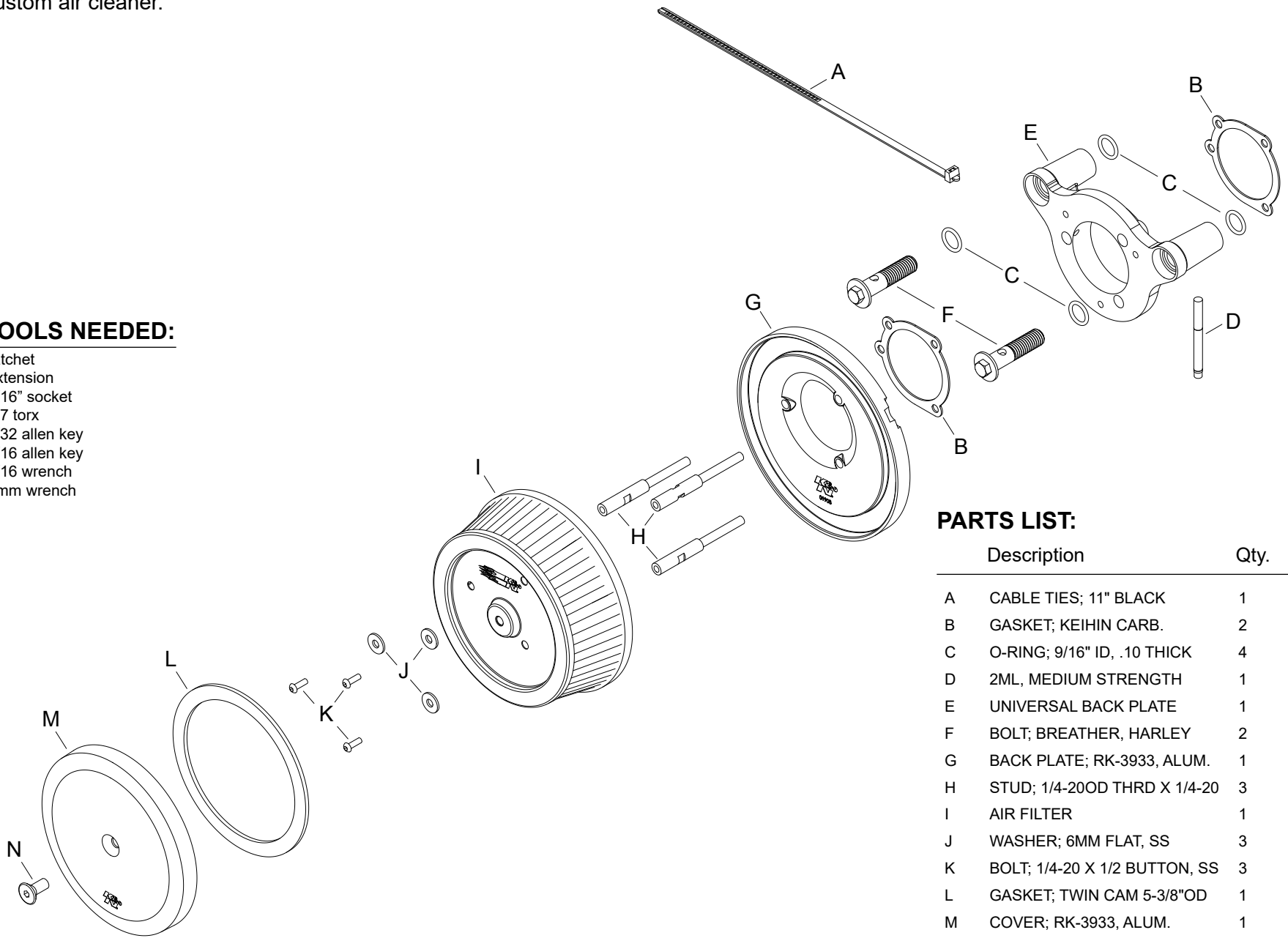

PARTS LIST:

	Description	Qty.	Part #
A	CABLE TIES; 11" BLACK	1	21590
B	GASKET; KEIHIN CARB.	2	09267
C	O-RING; 9/16" ID, .10 THICK	4	07761
D	2ML, MEDIUM STRENGTH	1	482
E	UNIVERSAL BACK PLATE	1	01933
F	BOLT; BREATHER, HARLEY	2	077007
G	BACK PLATE; RK-3933, ALUM.	1	01908
H	STUD; 1/4-20OD THRD X 1/4-20	3	070220
I	AIR FILTER	1	HD-0800
J	WASHER; 6MM FLAT, SS	3	08269
K	BOLT; 1/4-20 X 1/2 BUTTON, SS	3	07706
L	GASKET; TWIN CAM 5-3/8"OD	1	10486
M	COVER; RK-3933, ALUM.	1	01909
N	BOLT; 5/16-18 X 3/4 F/H/A, SS	1	22219

NOTE: FAILURE TO FOLLOW INSTALLATION INSTRUCTIONS AND NOT USING THE PROVIDED HARDWARE MAY DAMAGE THE INTAKE TUBE, THROTTLE BODY AND ENGINE.

TO START:

1. Turn off the ignition and disconnect the negative battery cable.



2. Remove the bolts securing the air filter bonnet and then remove the bonnet.

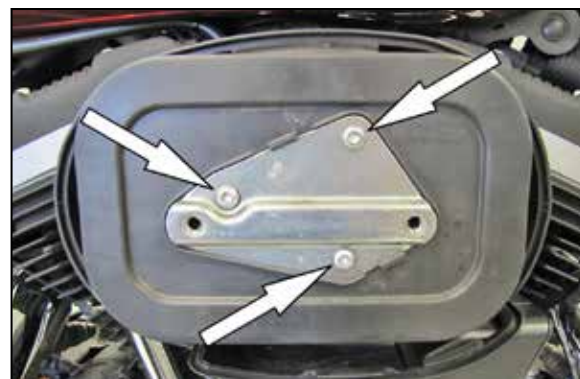

3. Remove the three bolts securing the factory air filter and bonnet bracket and then remove the factory air filter.



4. Remove the O-Rings from the breather bolts and then remove the breather bolts and rear air filter housing.

NOTE: K&N Engineering, Inc. recommends that customers do not discard the factory air intake components.



5. Remove the bolt securing the throttle body bracket and then remove the throttle body bracket from the vehicle.



6. Install two of the provided O-Rings into the K&N® throttle body bracket as shown.



7. Install the two remaining O-Rings into the front side of the K&N® throttle body bracket, then insert the two provided breather bolts through and attach the assembly to the cylinder heads but do not completely tighten. Insert the provided throttle body gasket and then install the filter spacer bolts to hold the gasket in place. Tighten the breather bolts and then remove the filter spacer bolts.

NOTE: Be sure to place one drop of thread locker onto the threads of the breather bolts.



8. Install the filter back plate and secure with the filter spacer bolts.

NOTE: be sure to place one drop of thread locker onto the threads of the spacer bolts.



9. Install the provided gasket onto the K&N® air filter as shown.



10. Install the K&N® air filter onto the back plate and secure with the provided hardware.

NOTE: Be sure to place one drop of the provided thread locker onto the threads of the bolts.



11. Install the filter cover and secure with the provided bolt.

NOTE: Be sure to place one drop of the provided thread locker onto the threads of the cover bolt.

12. Reconnect the vehicle's negative battery cable. Double check to make sure everything is tight and properly positioned before starting the vehicle.

13. The C.A.R.B. exemption sticker, (attached), must be visible, so the emissions inspector can see it when the vehicle is required to be tested for emissions. California requires testing every two years, other states may vary.

14. It will be necessary for all K&N® custom air cleaners to be checked periodically for realignment, clearance and tightening of all connections. Failure to follow the above instructions or proper maintenance may void warranty.

ROAD TESTING:

1. Start the engine with the transmission in neutral. Listen for air leaks or odd noises. For air leaks secure hoses and connections. For odd noises, find cause and repair before proceeding. This kit will function identically to the factory system except for being louder and much more responsive.

2. Test ride the vehicle. Listen for odd noises or rattles and fix as necessary.

3. If road test is fine, you can now enjoy the added power and performance from your kit.

4. K&N Engineering, Inc., requires cleaning the intake system's air filter element every 50,000 miles. When used in dusty or off-road environments, our filters will require cleaning more often. We recommend that you visually inspect your filter once every 25,000 miles to determine if the screen is still visible. When the screen is no longer visible some place on the filter element, it is time to clean it. To clean and re-oil, purchase our filter Recharger® service kit, part number 99-5050 or 99-5000 and follow the easy instructions.

INTAKE SYSTEMS FOR VEHICLES LISTED ARE 50 STATE LEGAL.