



INSTALLATION INSTRUCTIONS

PART NUMBER: RK-3932X

This Assembly Fits:

SEE CATALOG FOR CURRENT APPLICATIONS

Congratulations, you have purchased the finest custom air cleaner that money can buy. With proper care, this filter will last 1 million miles or more. This custom air cleaner replaces the stock air cleaner assembly. The following procedure **MUST** be followed to ensure a proper fit and seal of the custom air cleaner.

TOOLS NEEDED:

Ratchet
Extension
7/16" Socket
5/16" Hex Key Wrench
3/32" Hex Key Wrench
3/16" Hex Key Wrench
T27 Torx

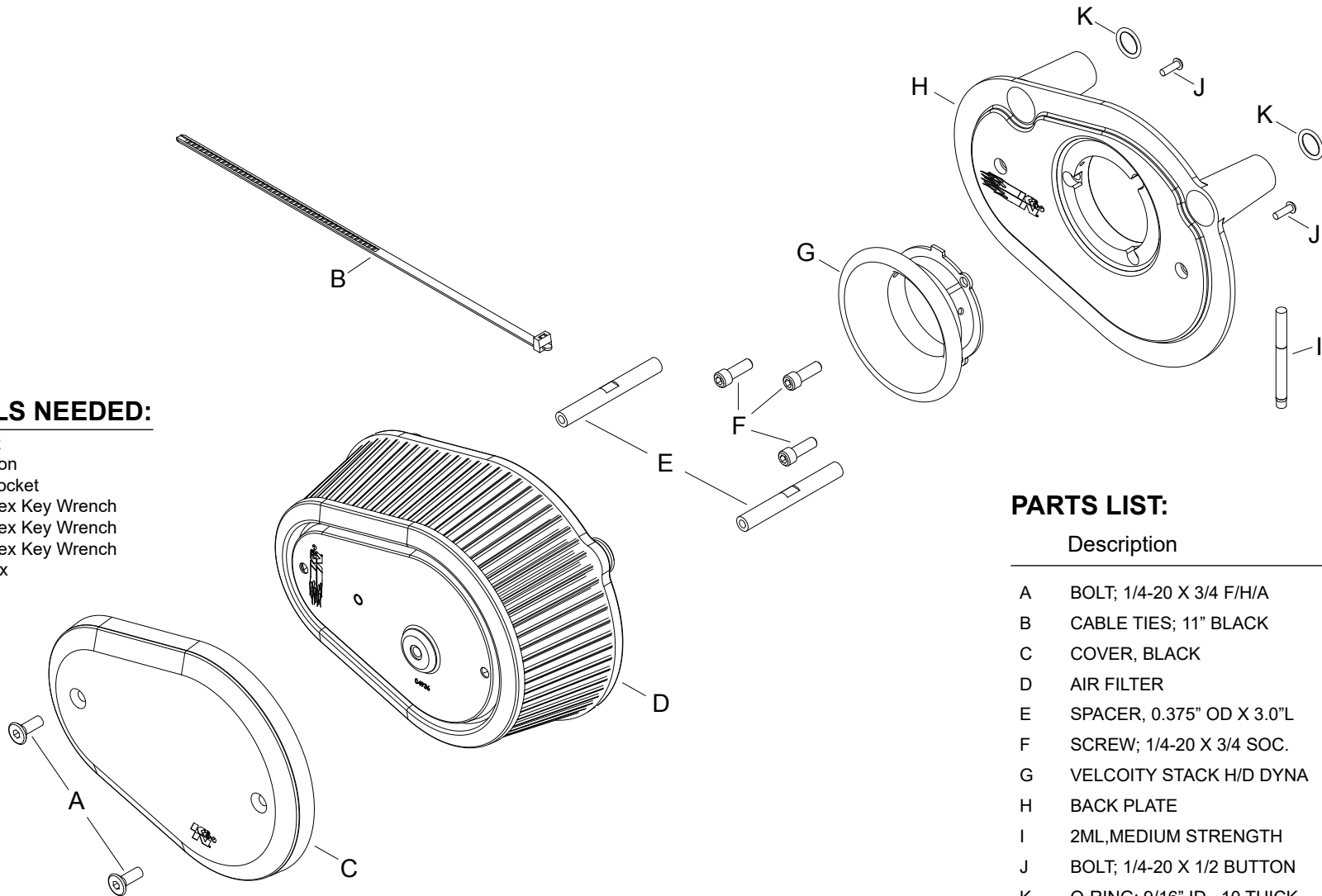

PARTS LIST:

Description	Qty.	Part #
A BOLT; 1/4-20 X 3/4 F/H/A	2	22218
B CABLE TIES; 11" BLACK	1	21590
C COVER, BLACK	1	01910
D AIR FILTER	1	E-3986
E SPACER, 0.375" OD X 3.0"L	2	06409
F SCREW; 1/4-20 X 3/4 SOC.	3	07731
G VELCOITY STACK H/D DYNA	1	08936
H BACK PLATE	1	01906TK
I 2ML, MEDIUM STRENGTH	1	482
J BOLT; 1/4-20 X 1/2 BUTTON	2	07706
K O-RING; 9/16" ID, .10 THICK	2	07761

NOTE: FAILURE TO FOLLOW INSTALLATION INSTRUCTIONS AND NOT USING THE PROVIDED HARDWARE MAY DAMAGE THE INTAKE TUBE, THROTTLE BODY AND ENGINE.

TO START:

1. Turn off the ignition and disconnect the negative battery cable.



2. Remove the bolt which secures the bonnet to the filter assembly and then remove the bonnet from the vehicle.

NOTE: The Bonnet may be a different style than pictured.

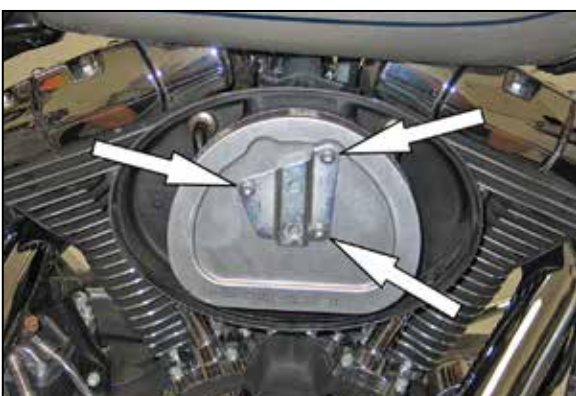

3. Remove the three bolts which secure the air filter to the filter base and then remove the air filter along with the crank case breather tubes.

NOTE: The factory air filter may differ from the picture; it may also have a bracket attached.



4. Remove the two crank case breather bolts shown.

NOTE: These bolts will be reused in a later step. There may also be two rubber tubes attached to the bolts that guide crank case vapor, these will need to be removed before the bolts can be removed.



5. Remove the air filter base from the throttle body and unhook the wiring pig tail from the filter base.

NOTE: Some models do not have the wiring pigtail.

NOTE: K&N Engineering, Inc. recommends that customers do not discard the factory air intake components.



6. On Models equipped with the electrical pigtail, using the provided tie wrap, secure the wiring pig tail to the throttle body wiring harness.



7. Install the venturi and three bolts provided into the filter base plate as shown.

NOTE: The bolts pass through the base plate and the venturi on the back side.



8. Install the two spacers onto the base plate as shown with the hardware provided.

NOTE: Place one drop of thread locker onto the threads of the bolts.



9. Install the two provided O-rings onto the filter base plate as shown.



10. Install the filter base plate onto the throttle body using the factory breather bolts and the throttle bolts installed during step #7. Alternate the tightening sequence between all five bolts until the base plate is completely tight.

NOTE: Apply one drop of thread locker to each bolt. Watch to make sure that the O-rings are seated into the receiver grooves as the base plate is tightened.



11. Set the top plate onto the air filter and then install the filter assembly onto the vehicle and secure with the provide hardware.

NOTE: apply one drop of thread locker to each bolt.



12. Reconnect the vehicle's negative battery cable. Double check to make sure everything is tight and properly positioned before starting the vehicle.

13. The C.A.R.B. exemption sticker, (attached), must be visible, so the emissions inspector can see it when the vehicle is required to be tested for emissions. California requires testing every two years, other states may vary.

14. It will be necessary for all K&N® custom air cleaners to be checked periodically for realignment, clearance and tightening of all connections. Failure to follow the above instructions or proper maintenance may void warranty.

ROAD TESTING:

1. Start the engine with the transmission in neutral. Listen for air leaks or odd noises. For air leaks secure hoses and connections. For odd noises, find cause and repair before proceeding. This kit will function identically to the factory system except for being louder and much more responsive.

2. Test ride the vehicle. Listen for odd noises or rattles and fix as necessary.

3. If road test is fine, you can now enjoy the added power and performance from your kit.

4. K&N Engineering, Inc., requires cleaning the intake system's air filter element every 50,000 miles. When used in dusty or off-road environments, our filters will require cleaning more often. We recommend that you visually inspect your filter once every 25,000 miles to determine if the screen is still visible. When the screen is no longer visible some place on the filter element, it is time to clean it. To clean and re-oil, purchase our filter Recharger® service kit, part number 99-5050 or 99-5000 and follow the easy instructions.

INTAKE SYSTEMS FOR VEHICLES LISTED ARE 50 STATE LEGAL.