



# INSTALLATION INSTRUCTIONS

## Part Number: KA-4018

This filter fits: SEE CATALOG FOR CURRENT APPLICATIONS

Congratulations, you have purchased the finest air filter that money can buy. With proper care, this filter will last 1 million miles or more. This filter can be used in a stock machine, with no modifications required. If any engine modifications have been made tuning/jetting adjustments may be required. There are special installation instructions, so please follow the procedures outlined below to ensure the K&N® Filtercharger® seals properly.

### INSTALLATION:

1. Remove the stock air filter from the air box. (Fig. 1)
2. Remove the screw from the stock air filter by pushing it out from the back side. (Fig. 2)
3. Install the screw that was removed in the above step into the K&N® filter as shown, using the supplied retainer. (Fig. 3)  
**NOTE: Be sure to fully thread the retainer onto the screw so it sits in the filter cavity.** (Fig. 4 & 5)
4. Install the K&N® filter into the air box and tighten the filter retaining screw. (Fig. 6)
5. Re-install the air box lid to complete installation.

**THESE INSTRUCTIONS MUST BE FOLLOWED EVERY TIME THE FILTER IS SERVICED, OTHERWISE THE FILTER MAY NOT SEAL, AND DAMAGE TO THE ENGINE COULD RESULT.**



Fig. 1



Fig. 2



Fig. 3

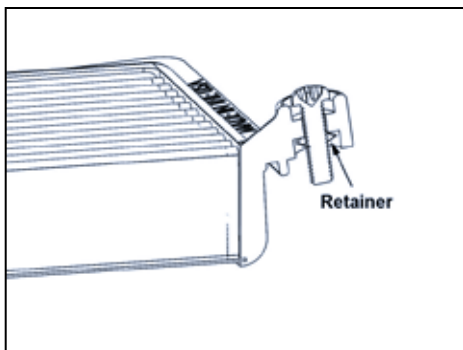

Fig. 4



Fig. 5



Fig. 6

### CLEANING:

K&N Engineering, Inc., suggests checking the air filter element periodically for excessive dirt build-up. Depending on your driving conditions, we recommend cleaning your air filter every 50,000 miles. To clean and re-oil, purchase our filter Recharger® service kit, part number 99-5050 or 99-5000 and follow the easy instructions.