



# AIRCHARGER®

## HIGH-FLOW INTAKE KITS

### INSTALLATION INSTRUCTIONS

63-1130

HARLEY DAVIDSON

2015 Street

750cc / 500cc

**TOOLS NEEDED:**

10mm wrench, 4mm allen key, 5mm allen key, Pliers

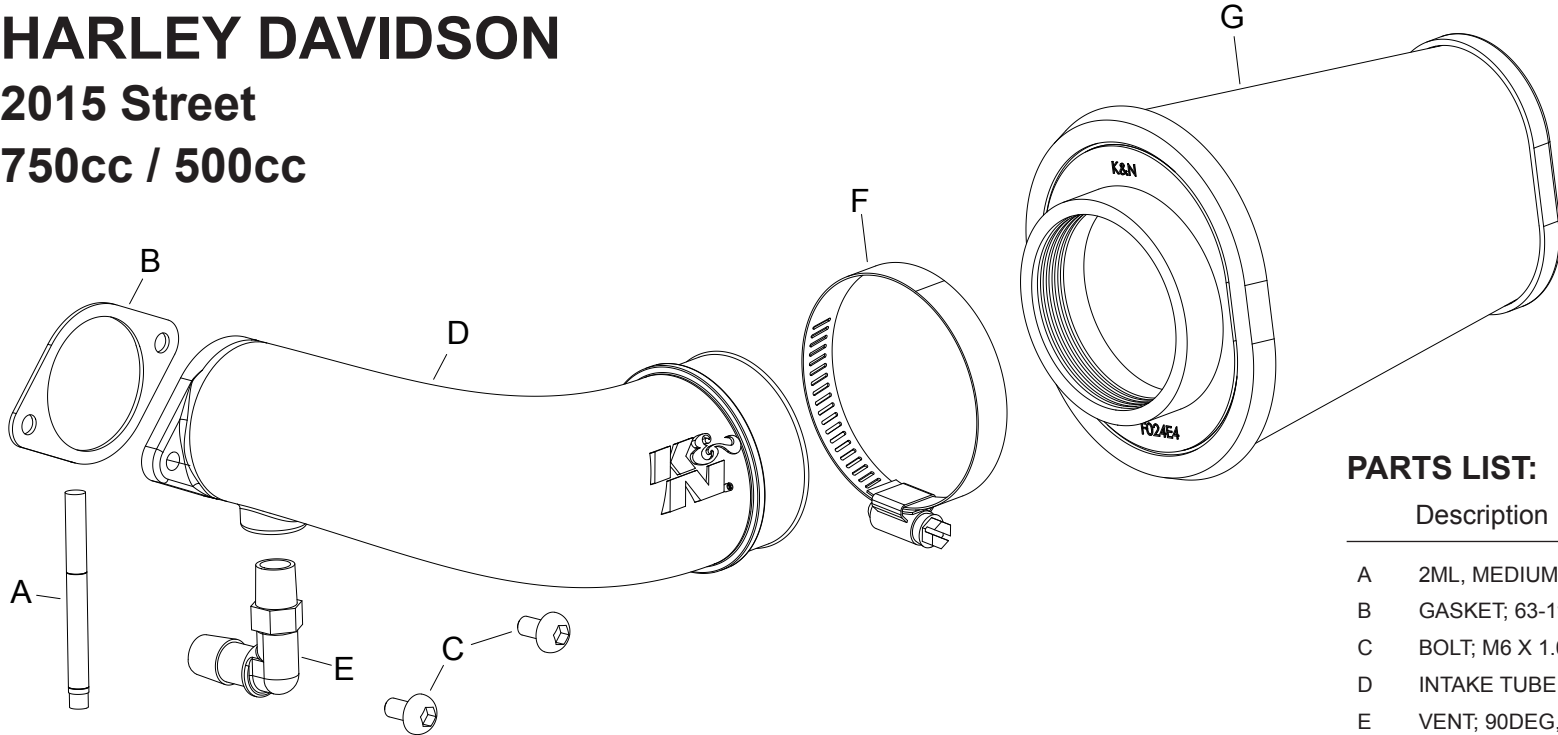

**PARTS LIST:**

	Description	Qty.	Part #
A	2ML, MEDIUM STRENGTH	1	482
B	GASKET; 63-1130, 1/16	1	09384
C	BOLT; M6 X 1.00" 12MM, SS	2	07794
D	INTAKE TUBE	1	088047
E	VENT; 90DEG, 1/2"HOSE, 1/4"	1	08110FK
F	HOSE CLAMP #40	1	08554
G	FILTER CHARGER	1	RE-0960

**NOTE: FAILURE TO FOLLOW INSTALLATION INSTRUCTIONS AND NOT USING THE PROVIDED HARDWARE MAY DAMAGE THE INTAKE TUBE, THROTTLE BODY AND ENGINE.**

**TO START:**

1. Turn off the ignition and disconnect the negative battery cable.  
**NOTE: Disconnecting the negative battery cable erases pre-programmed electronic memories. Write down all memory settings before disconnecting the negative battery cable. Some radios will require an anti-theft code to be entered after the battery is reconnected. The anti-theft code is typically supplied with your owner's manual. In the event your vehicles anti-theft code cannot be recovered, contact an authorized dealership to obtain your vehicles anti-theft code.**



2. Remove the bolt which secures the bonnet cover and then remove the bonnet.

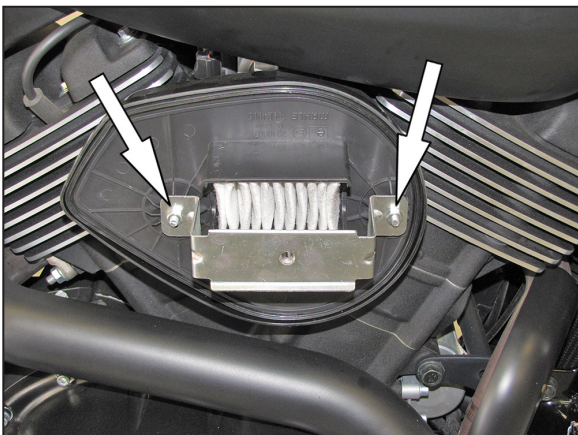

3. Remove the two nuts that secure the bonnet mounting bracket and factory air filter then remove the bracket and air filter.

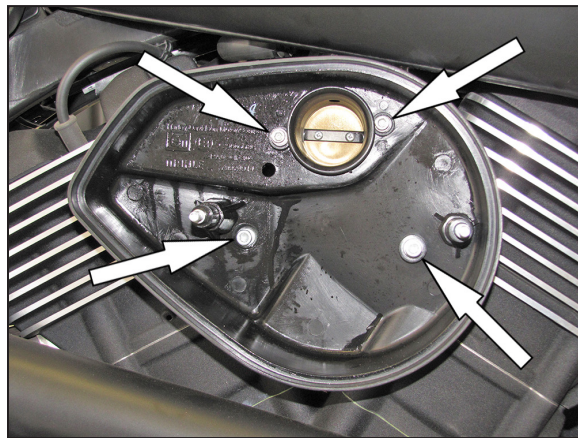

4. Remove the two throttle body bolts and the two filter back plate mounting bolts shown.  
**NOTE: The two throttle body bolts will be reused in a later step.**

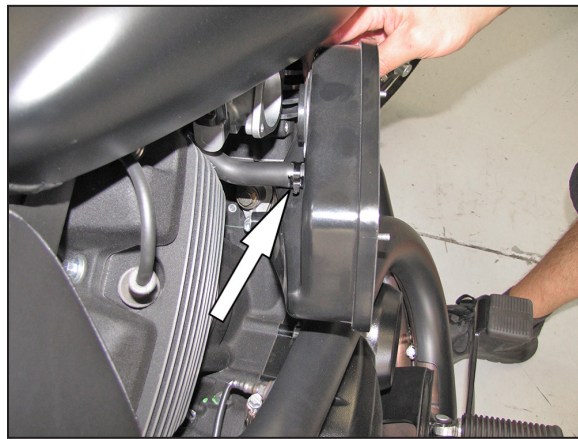

5. Pull the filter back plate away so that the crank case breather hose connection can be accessed. Release the spring clamp and then disconnect the crank case breather and remove the back plate from the vehicle.

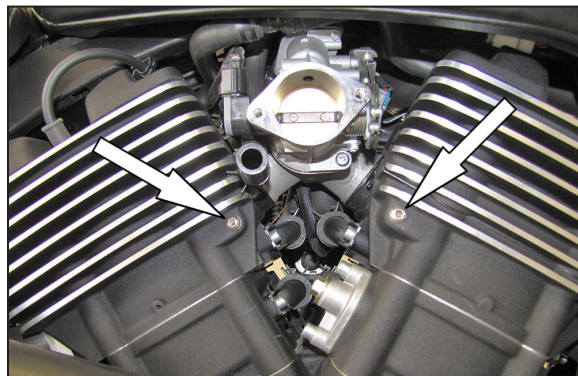

6. Install the two provided button head bolts into the factory air filter back plate mounting locations.



7. Install the provided 90° fitting into the K&N® throttle body adapter tube as shown.  
**NOTE: Plastic NPT fittings are easy to cross thread. Install the vent fitting "hand" tight, then turn it two complete turns with a wrench.**



8. Connect the factory crank case breather hose to the fitting installed into the K&N® throttle body adapter tube. Using the factory hardware and gasket, secure the throttle body to the throttle body as shown.

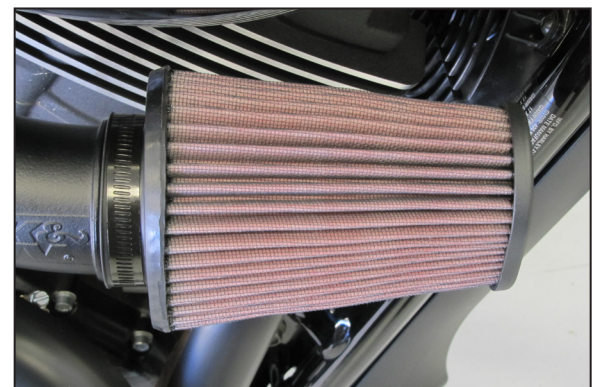

9. Install the K&N® air filter and secure with the provided hose clamp.



10. Reconnect the vehicle's negative battery cable. Double check to make sure everything is tight and properly positioned before starting the vehicle.

11. It will be necessary for all K&N® high flow intake systems to be checked periodically for realignment, clearance and tightening of all connections. Failure to follow the above instructions or proper maintenance may void warranty.

#### ROAD TESTING:

1. Start the engine with the transmission in neutral or park, and the parking brake engaged. Listen for air leaks or odd noises. For air leaks secure hoses and connections. For odd noises, find cause and repair before proceeding. This kit will function identically to the factory system except for being louder and much more responsive.

2. Test drive the vehicle. Listen for odd noises or rattles and fix as necessary.

3. If road test is fine, you can now enjoy the added power and performance from your kit.

4. K&N Engineering, Inc., requires cleaning the intake system's air filter element every 100,000 miles. When used in dusty or off-road environments, our filters will require cleaning more often. We recommend that you visually inspect your filter once every 25,000 miles to determine if the screen is still visible. When the screen is no longer visible some place on the filter element, it is time to clean it. To clean and re-oil, purchase our filter Recharger® service kit, part number 99-5050 or 99-5000 and follow the easy instructions.