



AIRCHARGER[®]

HIGH-FLOW INTAKE KITS

INSTALLATION INSTRUCTIONS

63-1126

63-1126P

HARLEY DAVIDSON

SEE CATALOG OR KNFILTERS.COM
FOR CURRENT APPLICATIONS

TOOLS NEEDED:

- Ratchet
- Extension
- 3/4" Socket
- 9/16" Allen Wrench
- 4mm Allen Wrench
- T27 Torx.
- Screwdriver

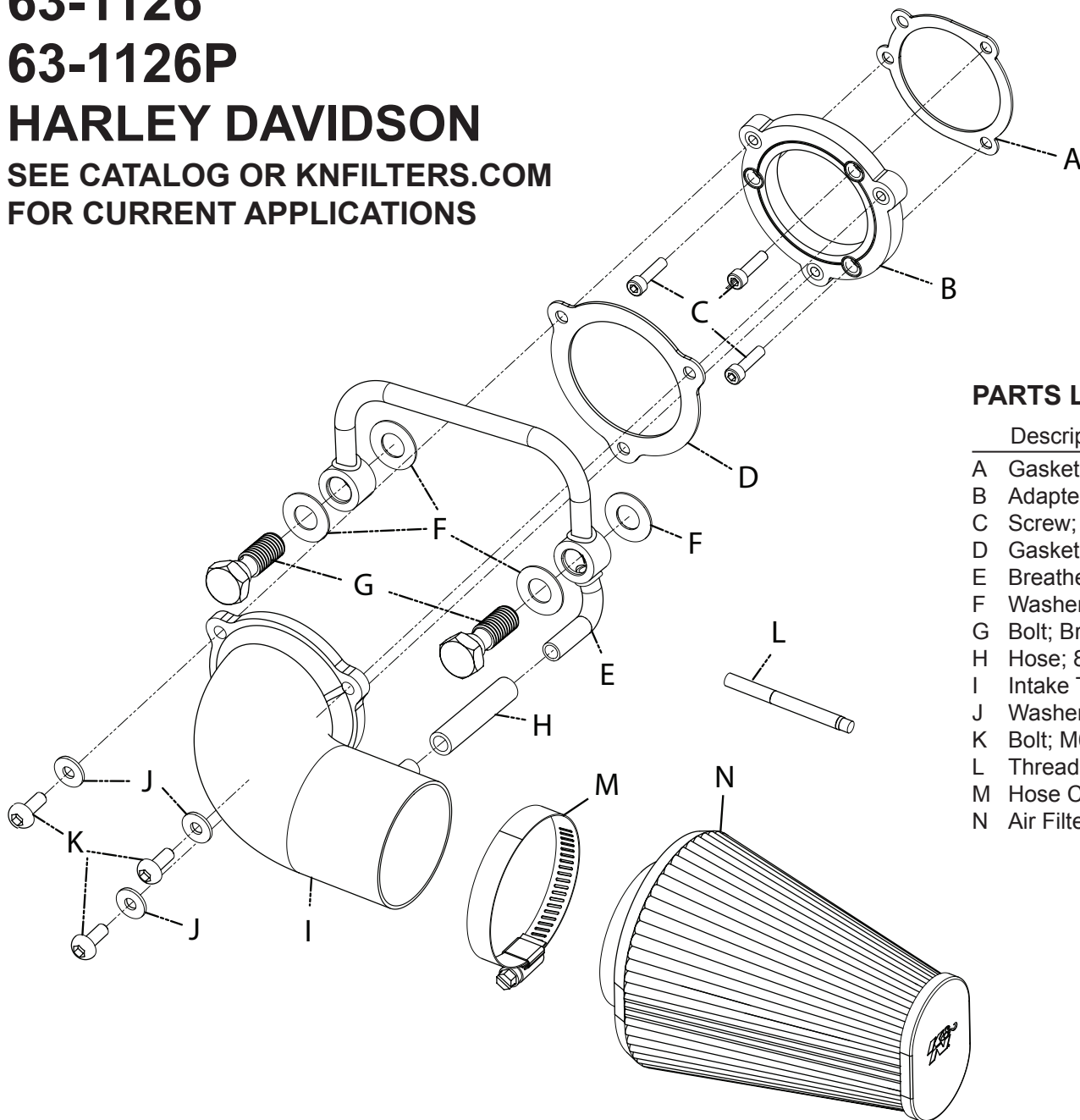

PARTS LIST:

Description	Qty.	Part #
A Gasket; Keihin Carb	1	09267
B Adapter; Harley Davidson	1	27318
C Screw; 1/4-20 X 3/4 Cap Screw, SS	3	07731
D Gasket; Harley Davidson,	1	09708
E Breather Tube; Harley Davidson	1	82627
F Washer; 1/2"ID, .040"THK	4	08322
G Bolt; Breather, Harley Davidson	2	22214
H Hose; 8MM ID X 2-1/4" L	1	08062
I Intake Tube	1	27405
J Washer; 6MM FLAT, SS	3	08269
K Bolt; M6 X 1.00 X 16MM, SS	3	07730
L Threadlocker,	1	482
M Hose Clamp# 40	1	08554K
N Air Filter	1	RE-0960 / RC-3680

NOTE: FAILURE TO FOLLOW INSTALLATION INSTRUCTIONS AND NOT USING THE PROVIDED HARDWARE MAY DAMAGE THE INTAKE TUBE, THROTTLE BODY AND ENGINE.

TO START:

1. Turn off the ignition and disconnect the negative battery cable.



2. Remove the two air filter cover mounting bolts and then remove the cover from the vehicle as shown.

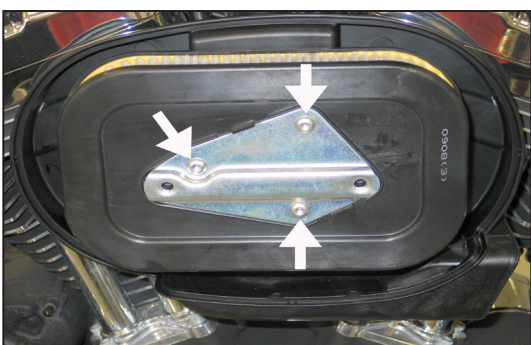

3. Remove the three air filter mounting bolts shown.



4. Remove the air filter as shown.

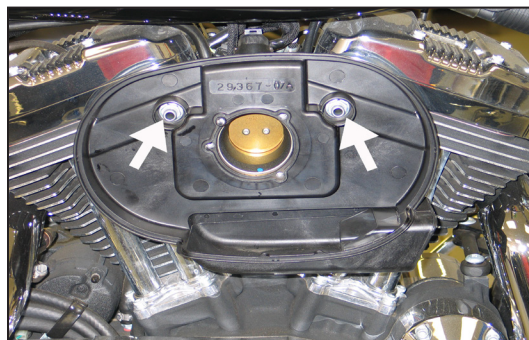

5. Remove the two breather bolts shown.



6. Remove the air filter base as shown.
NOTE: K&N Engineering, Inc. recommends that customers do not discard the factory air intake components.

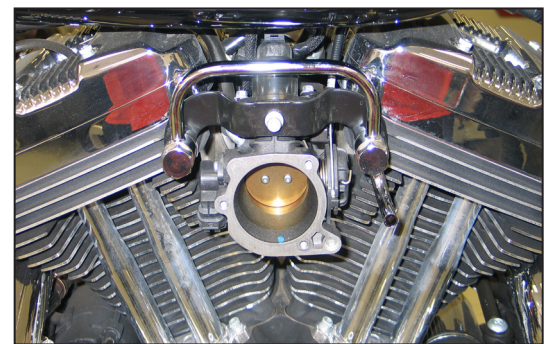

7. Install the K&N[®] crankcase breather tube onto the vehicle using the provided hardware.
NOTE: Do not completely tighten the breather bolts at this time.

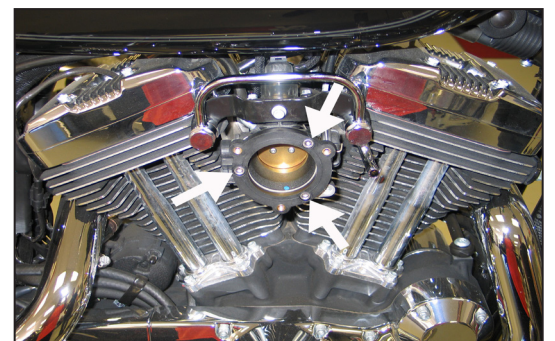

8. Install the K&N[®] intake tube adapter onto the throttle body using the provided hardware.
NOTE: Apply one drop of the provided thread locker to the three tube adapter mounting bolts.



9. Cut the provided crankcase vent hose to a length of 1.75" and install onto the K&N® intake tube as shown.

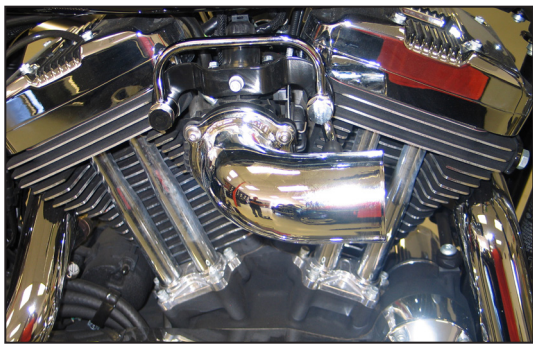

10. Install the K&N® intake tube onto the throttle body while attaching the vent hose to the vent tube and secure with the provided hardware.

NOTE: Apply one drop of the provided thread locker to the K&N® intake tube mounting bolts, adjust the vent tube and intake tube/throttle body for best fit, and tighten the mounting bolts.

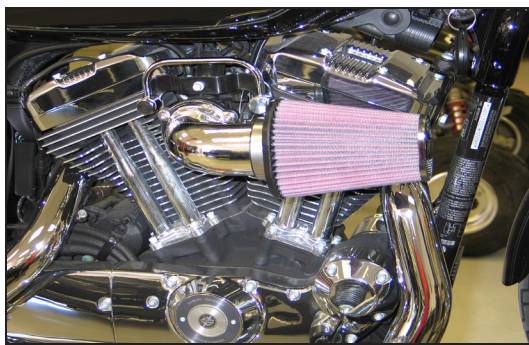

11. Install the K&N® air filter onto the K&N® intake tube and secure with the provided hose clamp. A black hose clamp is being supplied with kit. This clamp is intended to clamp the filter to the intake tube.

12. Double check to make sure everything is tight and properly positioned before starting the vehicle.

13. It will be necessary for all K&N® high flow intake systems to be checked periodically for realignment, clearance and tightening of all connections. Failure to follow the above instructions or proper maintenance may void warranty.

ROAD TESTING:

1. Start the engine with the transmission in neutral or park. Listen for air leaks or odd noises. For air leaks secure hoses and connections. For odd noises, find cause and repair before proceeding. This kit will function identically to the factory system except for being louder and much more responsive.

2. Test drive the vehicle. Listen for odd noises or rattles and fix as necessary.

3. If road test is fine, you can now enjoy the added power and performance from your kit.

4. K&N Engineering, Inc., suggests checking the air filter element periodically for excessive dirt build-up. When the element becomes covered in dirt (or once a year), service it according to the instructions on the Recharger® service kit, part number 99-5050 or 99-5000.