



INSTALLATION INSTRUCTIONS

PART NUMBER: RK-3934

Congratulations, you have purchased the finest custom air cleaner that money can buy. With proper care, this filter will last 1 million miles or more. This custom air cleaner replaces the stock air cleaner assembly. The following procedure must be followed to ensure a proper fit and seal of the custom air cleaner.

TOOLS:

- Ratchet
- Extension
- 7/16" Socket
- 5/16" Hex Key Wrench
- 3/32" Hex Key Wrench
- T27 Torx
- 7/16" Wrench

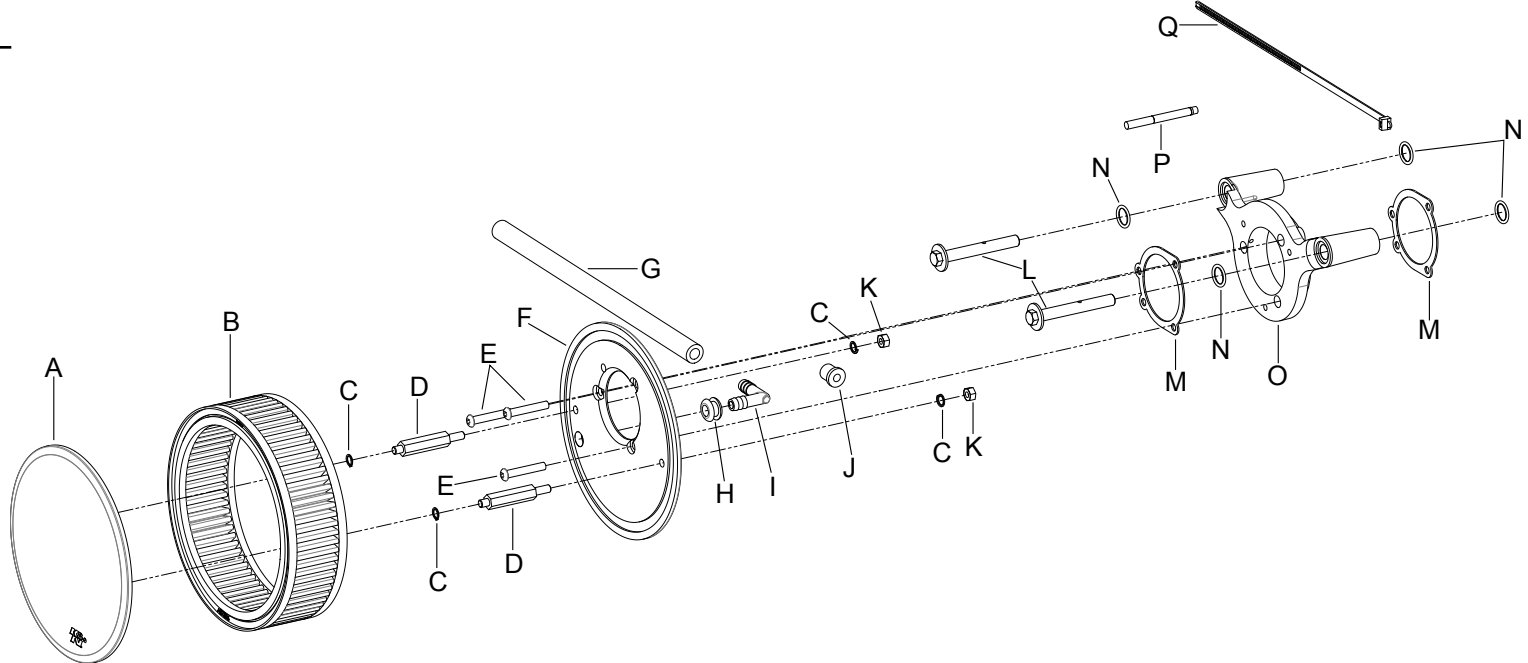

PARTS LIST:

Description	Qty.	Part #	Description	Qty.	Part #
A Front Plate, Smooth, Chrome Finish	1	05136	J Plug; Rubber	1	21678
B Element Parts Kit	1	E-3336	K Nut; 1/4-28, Zinc	2	07782
C Washer; 1/4" Lock, Zn	4	08198	L Bolt; Breather	2	22212
D Stud; 2.625 HX , BL/OX	2	08001	M Gasket; Keihin Carb.	2	09267
E Bolt; 1/4-20 X 1-1/2"L, Buttonhead, SS	3	22216	N O-ring; 9/16" ID, .10 Thick	4	07761
F Back Plate, Blk. Finish	1	01942	O Back Plate; Universal, Cast Alum. Machined, TK/PC	1	01907MTK
G Hose; 3/8" ID X 12" L	1	08412	P 2ML, Medium Strength, Blue	1	482
H Grommet; .750"OD, .375"ID, .500"Thk.	1	08060	Q Cable Ties; 11" Black	1	21590
I Vent; 90Deg., 3/8 X 3/8, Plastic	1	08121			

NOTE: FAILURE TO FOLLOW INSTALLATION INSTRUCTIONS AND NOT USING THE PROVIDED HARDWARE MAY DAMAGE THE THROTTLE BODY AND ENGINE.

TO START:

1. Turn off the ignition and disconnect the negative battery cable.



2. Remove the bolt which secures the bonnet to the filter assembly and then remove the bonnet from the vehicle.

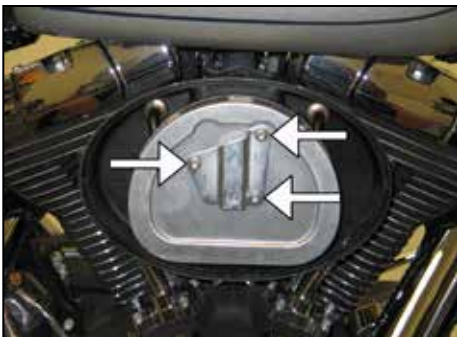

3. Remove the three bolts which secure the air filter to the filter base and then remove the [air filter](#) along with the crankcase breather tubes.

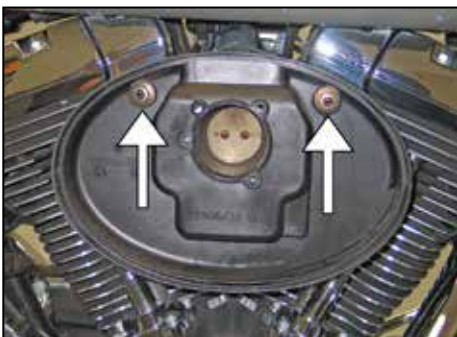

4. Remove the two crankcase breather bolts shown.



5. Remove the air filter base from the throttle body and unhook the wiring pig tail from the filter base. **NOTE: K&N Engineering, Inc. recommends that customers do not discard the factory air intake components.**

NOTE: Unhook the wiring pigtail from the rear of the filter base. On non-US models, disconnect the intake valve solenoid.

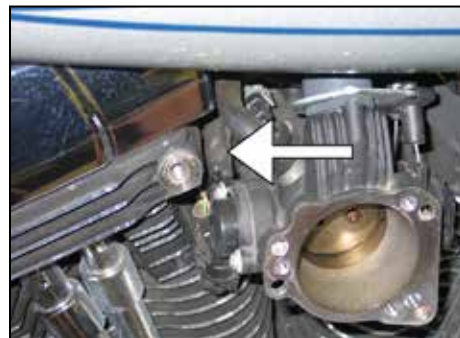

6. Using the provided tie wrap, secure the wiring pig tail to the throttle body wiring harness. **NOTE: On non-US models, a by-pass module (sold separately) will need to be installed onto the pigtail to eliminate an engine management light from turning on. (non-US models only)**

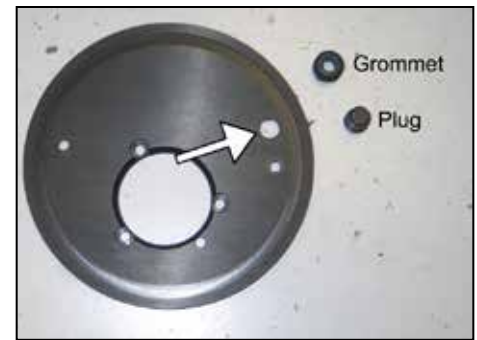

7. On vehicles equipped with a EVAP vent line, install the provided grommet into the hole shown. On vehicles not equipped with an EVAP vent line, install the provided plug into the hole shown from the back side of the base plate.



8. Install two of the provided O-rings into the crankcase breather plate as shown.



9. Install the crankcase breather plate along with the two remaining o-rings, mounting bolts (with one drop of thread locker) and throttle body gasket as shown.

NOTE: Install the three filter base plate bolts to hold the throttle body gasket in place until the two breather bolts are tightened, then remove the three filter base plate mounting bolts.



10. Install the three filter base plate mounting bolts into the base plate; install the remaining gasket and one drop of thread locker on each bolt. Secure the filter base plate to the breather plate as shown.

NOTE: On vehicles equipped with a EVAP vent line, connect the vent line to the base plate with the 90° hose mender and hose provided. Trimming of the hose will be necessary.

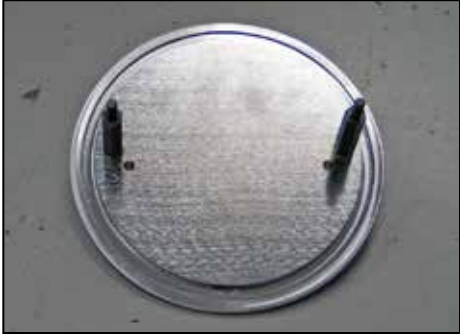

11. Apply thread locker to the two provided studs and then install the studs along with the lock washers onto the filter top plate as shown.



12. Install the K&N® air filter onto the top plate as shown.



13. Install the filter/top plate assembly onto the base plate and secure with the provided hardware and thread locker.



14. Reconnect the vehicle's negative battery cable. Double check to make sure everything is tight and properly positioned before starting the vehicle.

15. It will be necessary for all K&N® custom air cleaners to be checked periodically for realignment, clearance and tightening of all connections. Failure to follow the above instructions or proper maintenance may void warranty.

ROAD TESTING:

1. Start the engine with the transmission in neutral. Listen for air leaks or odd noises. For air leaks secure hoses and connections. For odd noises, find cause and repair before proceeding. This kit will function identically to the factory system except for being louder and much more responsive.

2. Test ride the vehicle. Listen for odd noises or rattles and fix as necessary.

3. If road test is fine, you can now enjoy the added power and performance from your kit.

4. K&N Engineering Inc., suggests checking the air filter element periodically for excessive dirt build-up. When the element becomes covered in dirt (or once a year), service it according to the instructions on the Recharger® service kit, part number 99-5050 or 99-5000.