



INSTALLATION INSTRUCTIONS

PART NUMBER: RK-3932

Congratulations, you have purchased the finest custom air cleaner that money can buy. With proper care, this filter will last 1 million miles or more. This custom air cleaner replaces the stock air cleaner assembly. The following procedure must be followed to ensure a proper fit and seal of the custom air cleaner.

TOOLS NEEDED:

Ratchet
Extension
7/16" Socket
5/16" Hex Key Wrench
3/32" Hex Key Wrench
3/16" Hex Key Wrench
T27 Torx

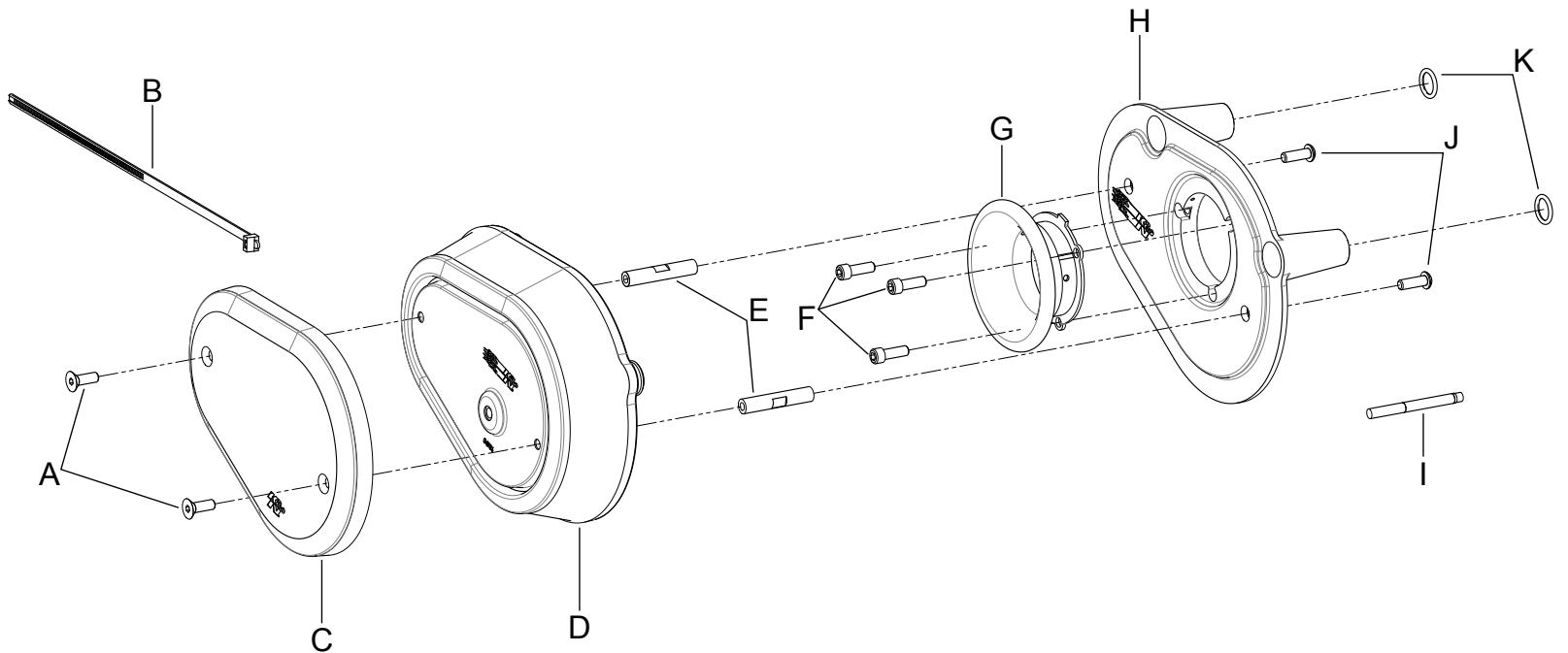

PARTS LIST:

Description	Qty.	Part #	Description	Qty.	Part #
A Bolt; 1/4-20 X 3/4 F/H/A, SS	2	22218	G Velcoity Stack H/D Dyna RK Kit	1	08936
B Cable Ties; 11" Black	1	21590	H Back Plate	1	01906TK
C Cover, Chrome	1	01910	I 2ML, Medium Strength, Blue	1	482
D Elements Parts Kit	1	E-3975	J Bolt; 1/4-20 X 1/2 Button Sockets, SS	2	07706
E Spacer, 0.375" OD X 0.25" ID X 2.0"L,	2	06500-1	K O-Ring; 9/16" ID, .10 Thick	2	07761
F Screw; 1/4-20 X 3/4 SOC. H/D Cap Screw, SS	3	07731			

NOTE: FAILURE TO FOLLOW INSTALLATION INSTRUCTIONS AND NOT USING THE PROVIDED HARDWARE MAY DAMAGE THE THROTTLE BODY AND ENGINE.

TO START:

1. Turn off the ignition and disconnect the negative battery cable.



2. Remove the bolt that secures the bonnet to the filter assembly and then remove the bonnet from the vehicle.

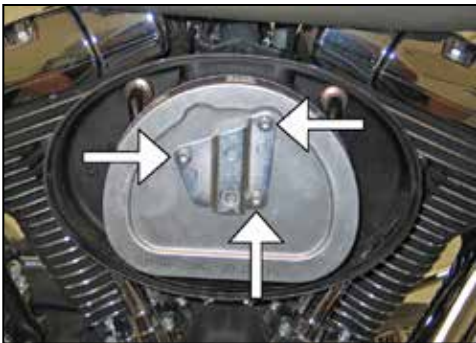

3. Remove the three bolts which secure the air filter to the filter base and then remove the [air filter](#) along with the crankcase breather tubes.



4. Remove the two crank case breather bolts shown.
NOTE: These bolts will be reused in a later step.



5. Remove the air filter base from the throttle body and unhook the wiring pig tail from the filter base.
NOTE: K&N Engineering, Inc., recommends that customers do not discard the factory air intake components.

NOTE: Unhook the wiring pigtail from the rear of the filter base. On non-US models, disconnect the intake valve solenoid.



6. Using the provided tie wrap, secure the wiring pig tail to the throttle body wiring harness.
NOTE: On non-US models, a by-pass module (sold separately) will need to be installed onto the pigtail to eliminate an engine management light from turning on. (non-US models only)



7. Install the venturi and three provided bolts into the K&N filter base plate as shown.
NOTE: The bolts pass through the base plate and the venturi on the back side.



8. Install the two spacers onto the K&N filter base plate with the provided hardware as shown.
NOTE: Place one drop of thread locker onto the threads of each bolts.



9. Install the two provided o-rings onto the K&N filter base plate as shown.



10. Install the K&N® filter base plate onto the throttle body using the factory breather bolts and the throttle bolts installed during step #7. Alternate the tightening sequence between all five bolts until the base plate is completely tight.

NOTE: Apply one drop of thread locker to each bolt. Watch to make sure that the o-rings are seated into the receiver grooves as the base plate is tightened.

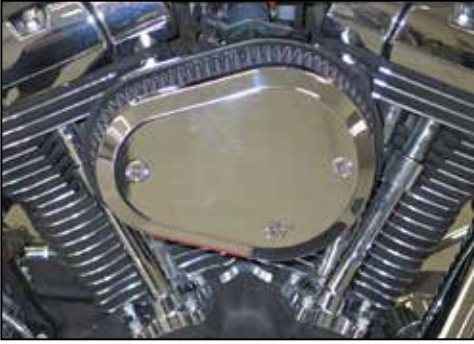

11. Set the top plate onto the K&N® air filter and install the filter assembly onto the vehicle, secure with the provided hardware.

NOTE: Apply one drop of thread locker to each bolt.



12. It will be necessary for all K&N® custom air cleaners to be checked periodically for realignment, clearance and tightening of all connections. Failure to follow the above instructions or proper maintenance may void warranty.

ROAD TESTING:

1. Start the engine with the transmission in neutral. Listen for air leaks or odd noises. For air leaks secure hoses and connections. For odd noises, find cause and repair before proceeding. This kit will function identically to the factory system except for being louder and much more responsive.

2. Test ride the vehicle. Listen for odd noises or rattles and fix as necessary.

3. If road test is fine, you can now enjoy the added power and performance from your kit.

4. K&N Engineering Inc., suggests checking the air filter element periodically for excessive dirt build-up. When the element becomes covered in dirt (or once a year), service it according to the instructions on the Recharger® service kit, part number 99-5050 or 99-5000.