



INSTALLATION INSTRUCTIONS

Part Number HA-6095

Congratulations, you have purchased the finest [air filter](#) that money can buy. With proper care, this filter will last 1 million miles or more. This filter can be used in a stock machine, with no modifications required. If any engine modifications have been made tuning/jetting adjustments may be required. There are special installation instructions, so please follow the procedures outlined below to ensure the K&N Filtercharger® seals properly.

INSTALLATION

1. Remove the stock air filter.
2. Remove the stock o-rings from the air box lid and base.
Note: The K&N Filtercharger® will not fit correctly with the o-rings in place.
3. Install the K&N Filtercharger® making sure it is completely seated into the grooves. **DO NOT FORCE THE AIR FILTER!**
Note: The K&N logo and part number will be facing down into the air box.
4. Insert the supplied baffle into the air box lid.
Note: The motorcycle will not run properly if this baffle is not installed. This baffle is designed to re-direct the incoming air.
5. Install the air box lid making sure the air filter sealing lip is completely seated into the groove.

THESE INSTRUCTIONS MUST BE FOLLOWED EVERY TIME THE FILTER IS SERVICED, OTHERWISE THE FILTER MAY NOT SEAL, AND DAMAGE TO THE ENGINE COULD RESULT.

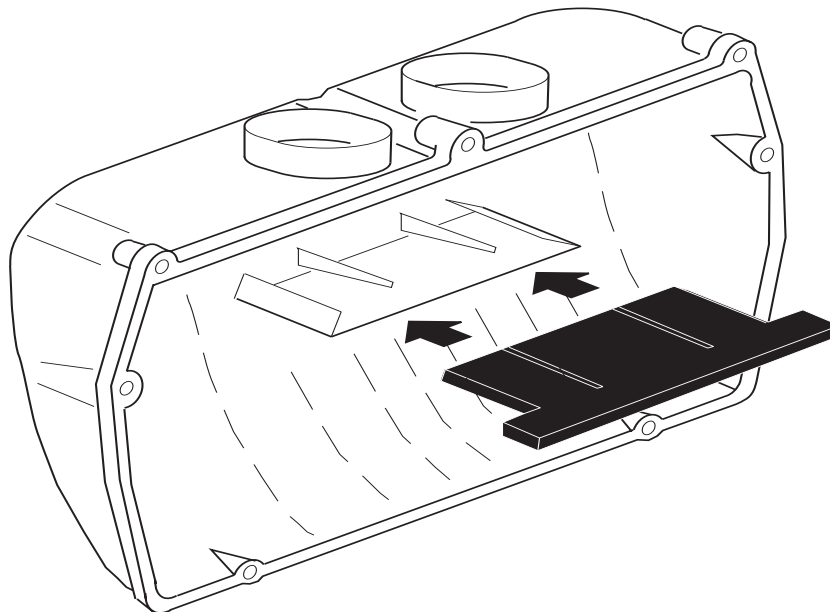

Fig. 1
