



INSTALLATION INSTRUCTIONS

PART NUMBER: HA-1008

Congratulations, you have just purchased the finest [air filter](#) that money can buy. With proper care, this filter will last 1 million miles or more. This filter can be used in a stock machine, with no modifications required. If any engine modifications have been made tuning/jetting adjustments may be required. There are special installation instructions, so please follow the procedures outlined below to ensure the K&N® air filter seals properly.

INSTALLATION:

1. Remove the stock air filter. Make sure to loosen three screws next to air horns.
2. Remove the two air filter screws from stock filter. (Fig.1)
3. Install the stock screw into provided steel filter plate and then install provided washer ensuring rounded side of washer sits against steel filter plate. Washer only needs to be threaded approximately half way onto screw. Repeat for other side of filter plate. (Fig.2)
CAUTION: The washers MUST installed correctly to keep the screws from backing out and going into the throttle body assembly.
4. Remove the stock o-ring where the air filter seats. (Fig.3)
5. Install the K&N® air filter into the groove in the air box. (Fig.4)
NOTE: Run your fingers along the perimeter of the air filter to make sure it is completely seated in the groove.
6. Install the air filter plate onto the K&N® air filter. The three tabs will go into the air filter retainers in the air box. (Fig.5)
7. Start the two screws on the filter plate first, drive the screws a majority of the way into the air box, then tighten the 3 screws next to the air horns. (Fig.6)
8. With the three screws next to the air horn tight, evenly tighten the two remaining screws on the filter plate.
NOTE: Do not apply too much pressure when tightening the last two screws on the filter plate.
9. Reinstall the air filter cover.

THESE INSTRUCTIONS MUST BE FOLLOWED EVERY TIME THE FILTER IS SERVICED, OTHERWISE THE FILTER MAY NOT SEAL, AND DAMAGE TO THE ENGINE COULD RESULT.

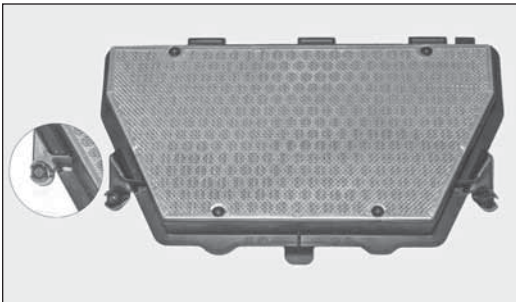

Fig 1.

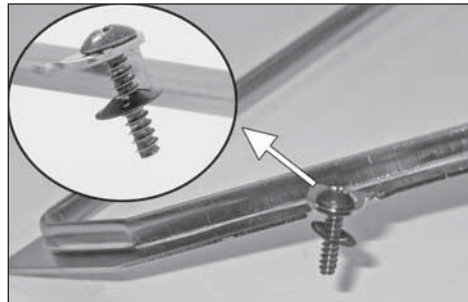

Fig 2.

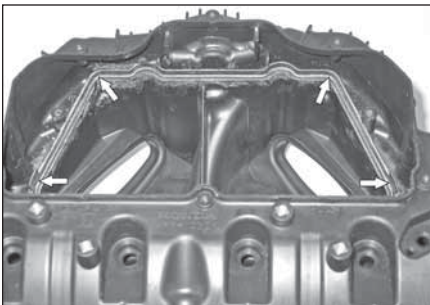

Fig 3.

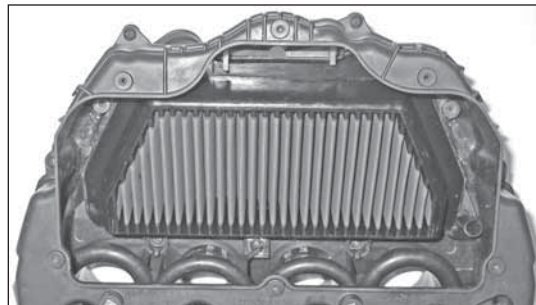

Fig 4.

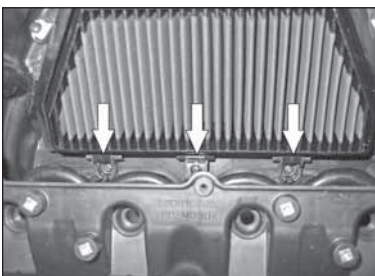

Fig 5.

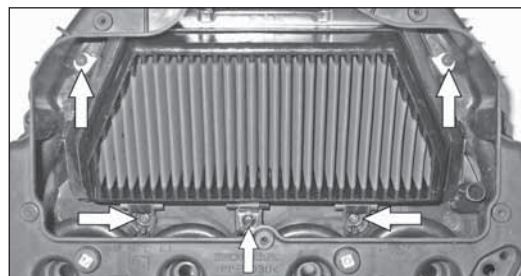

Fig 6.