



Installation Instructions

PART NUMBER: DU-6908

Congratulations, you have just purchased the finest [air filter](#) that money can buy. With proper care, this filter will last 1 million miles or more. This filter can be used in a stock machine, with no modifications required. If any engine modifications have been made tuning/jetting adjustments may be required. There are special installation instructions, so please follow the procedures outlined below to ensure the K&N air filter seals properly.

INSTALLATION:

1. Remove the stock air filter and holder from the air box. (Fig. 1)
2. Remove the stock air filter from the holder. (Fig. 2)
3. Clean the holder of any dirt.
4. Install the K&N Air Filter onto the holder making sure it is completely seated. (Fig. 3)
NOTE: The thin end will go into the base of the holder. (Fig. 3)
5. Install the filter case cover onto the K&N Air Filter. (Fig. 4)
6. Install the ring nut and tighten.
7. Install the air filter assembly into the air box making sure the three screw holes are lined up. (Fig. 5)
NOTE: The intake ducts on the filter case cover will line up with the ducts on the air box. (Fig. 5)
8. Install the three stock screws and tighten.

THESE INSTRUCTIONS MUST BE FOLLOWED EVERY TIME THE FILTER IS SERVICED, OTHERWISE THE FILTER MAY NOT SEAL, AND DAMAGE TO THE ENGINE COULD RESULT.

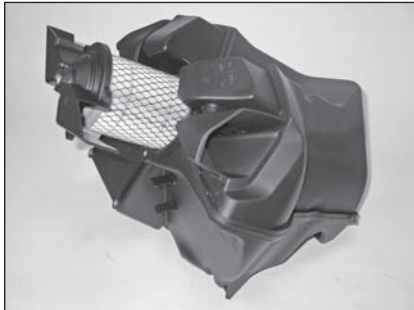

Fig. 1



Fig. 2



Fig. 3



Fig. 4

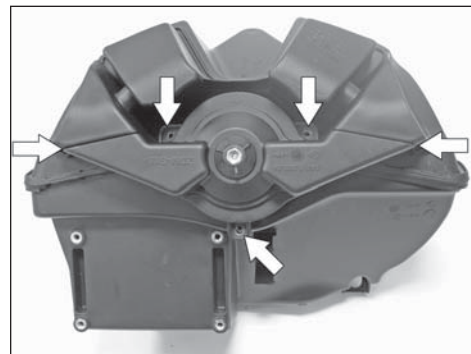

Fig. 5