



INSTALLATION INSTRUCTIONS

Part Number DU-0900

Congratulations, you have purchased the finest [air filter](#) that money can buy. With proper care, this filter will last 1 million miles or more. This filter can be used in a stock machine, with no modifications required. If any engine modifications have been made tuning/jetting adjustments may be required. There are special installation instructions, so please follow the procedures outlined below to ensure the K&N Filtercharger® seals properly.

INSTALLATION

1. Release all of the clips and completely remove the air box lid from the motorcycle.
2. Remove the stock air filter.
3. Carefully clean the inside of the air box.
4. Apply the provided K&N Sealing Grease to the air filter sealing surface of the air box and fill in each of the screw holes. (Fig. 1)
5. Install the K&N Filtercharger®.
6. Reinstall the air box lid.

THESE INSTRUCTIONS MUST BE FOLLOWED EVERY TIME THE FILTER IS SERVICED, OTHERWISE THE FILTER MAY NOT SEAL, AND DAMAGE TO THE ENGINE COULD RESULT.

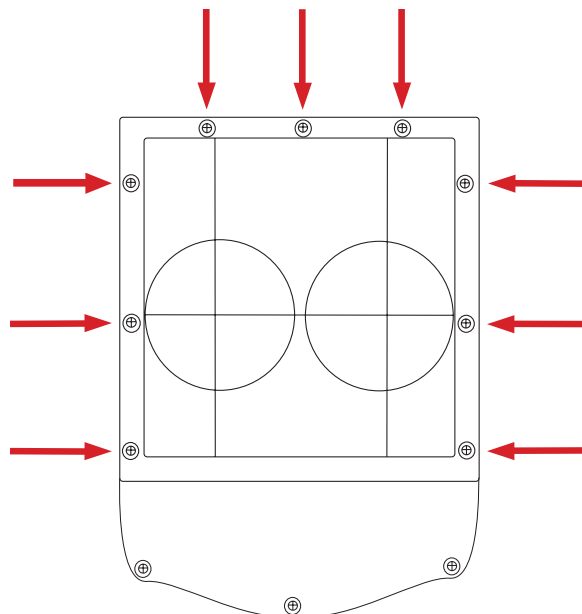

Fig. 1