

**CWTB**  
*Owner's Manual*

**CWTB8 | CWTB10**

LOADED WEATHER-PROOF ENCLOSURES

## CONTENTS

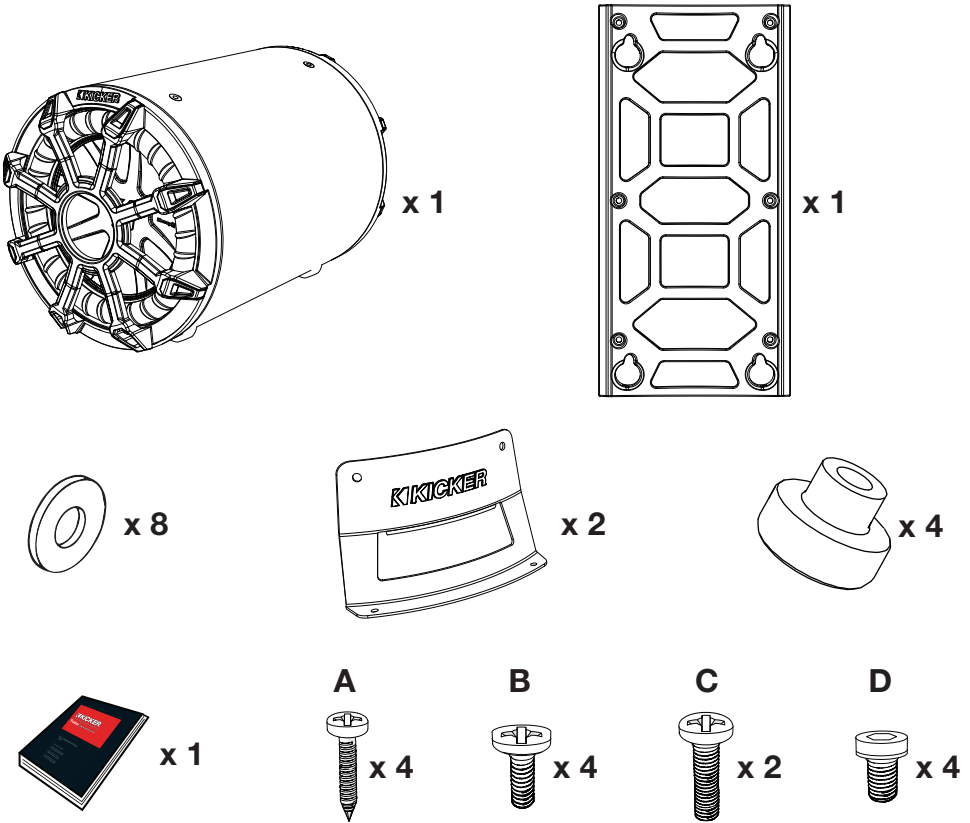

To avoid potential injury or possible death from forward movement of the enclosure during abrupt stops or accidents, the enclosure must be properly installed and securely fastened to your vehicle. You are solely responsible for securely fastening the enclosure in your vehicle.

# HORIZONTAL INSTALLATION

Mount the horizontal mounting plate to the vehicle.

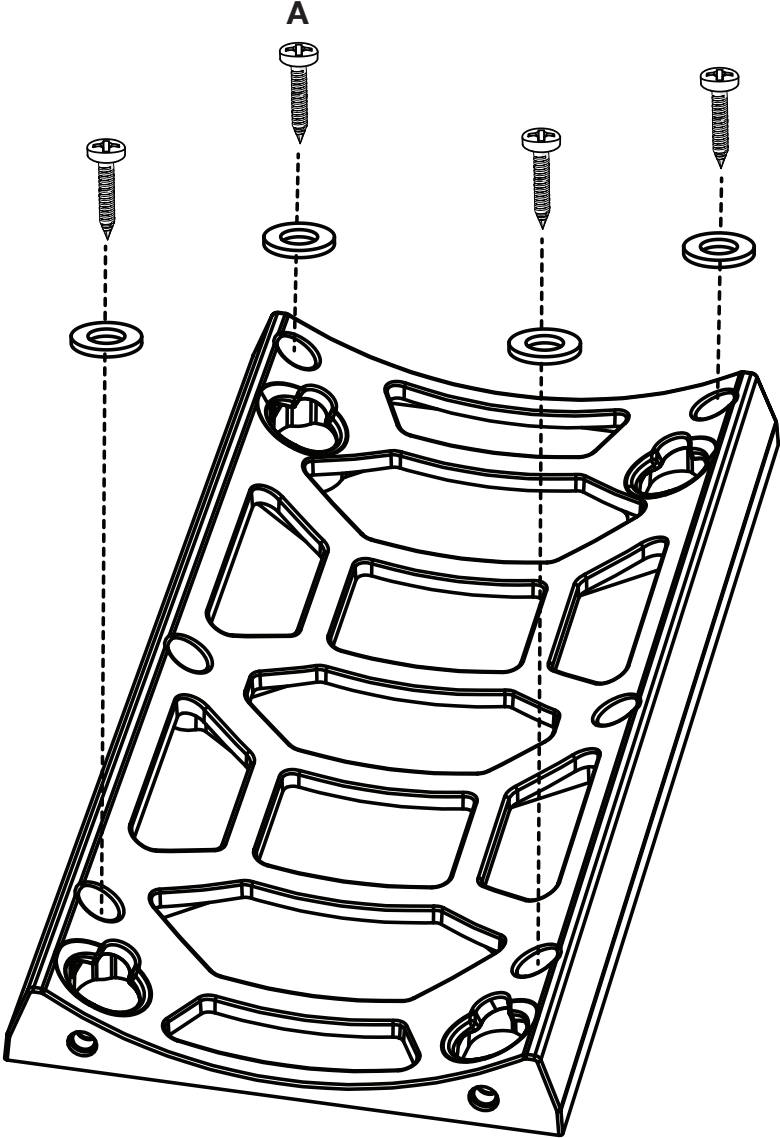

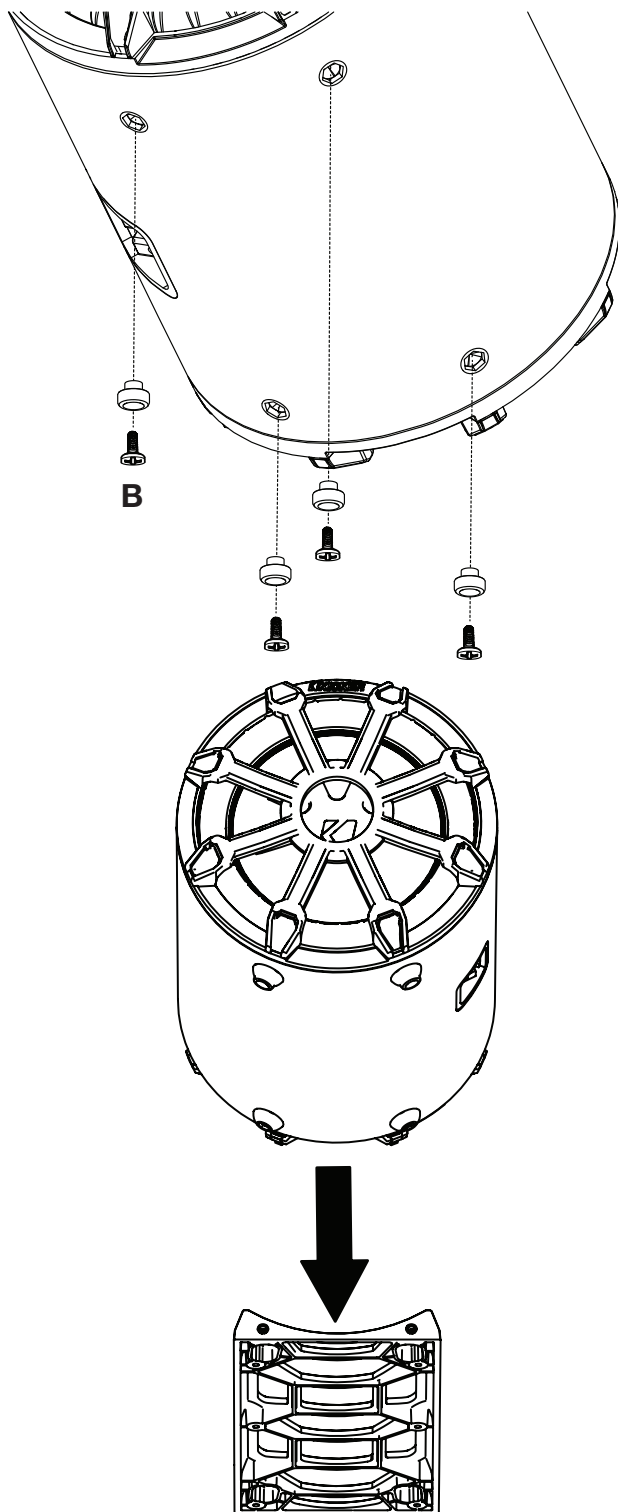

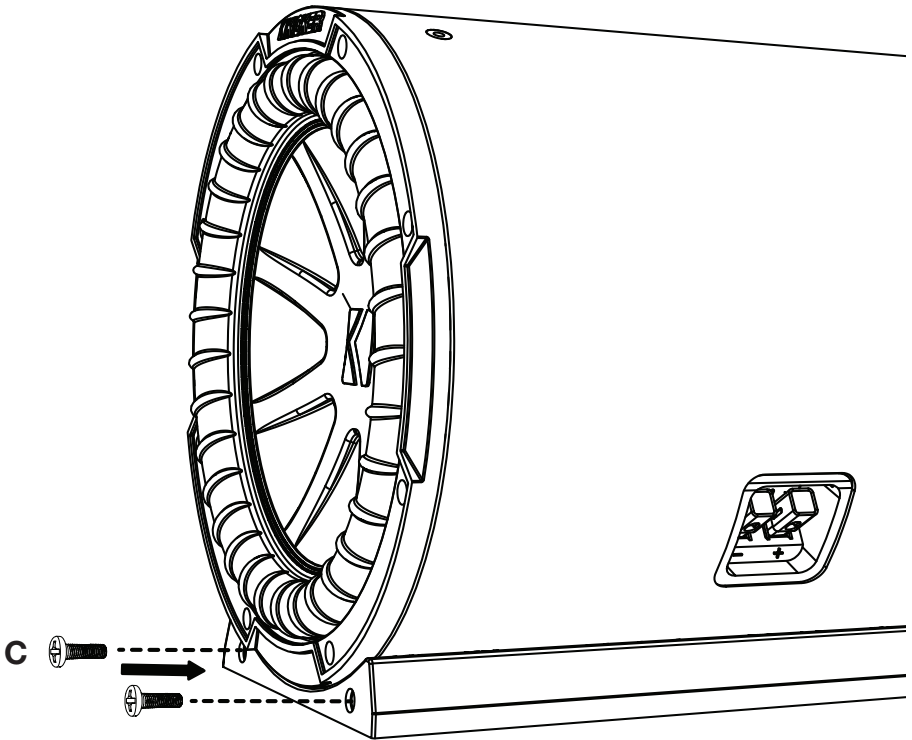
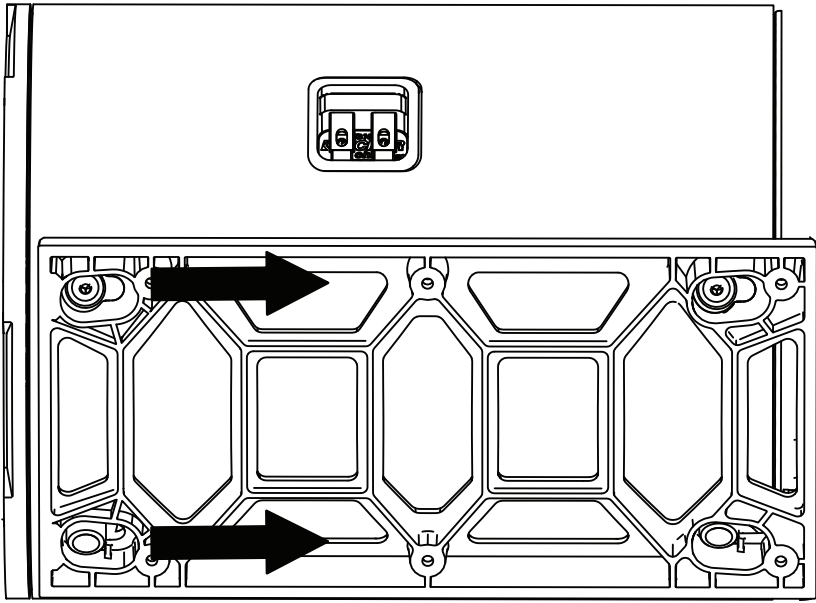

# VERTICAL INSTALLATION

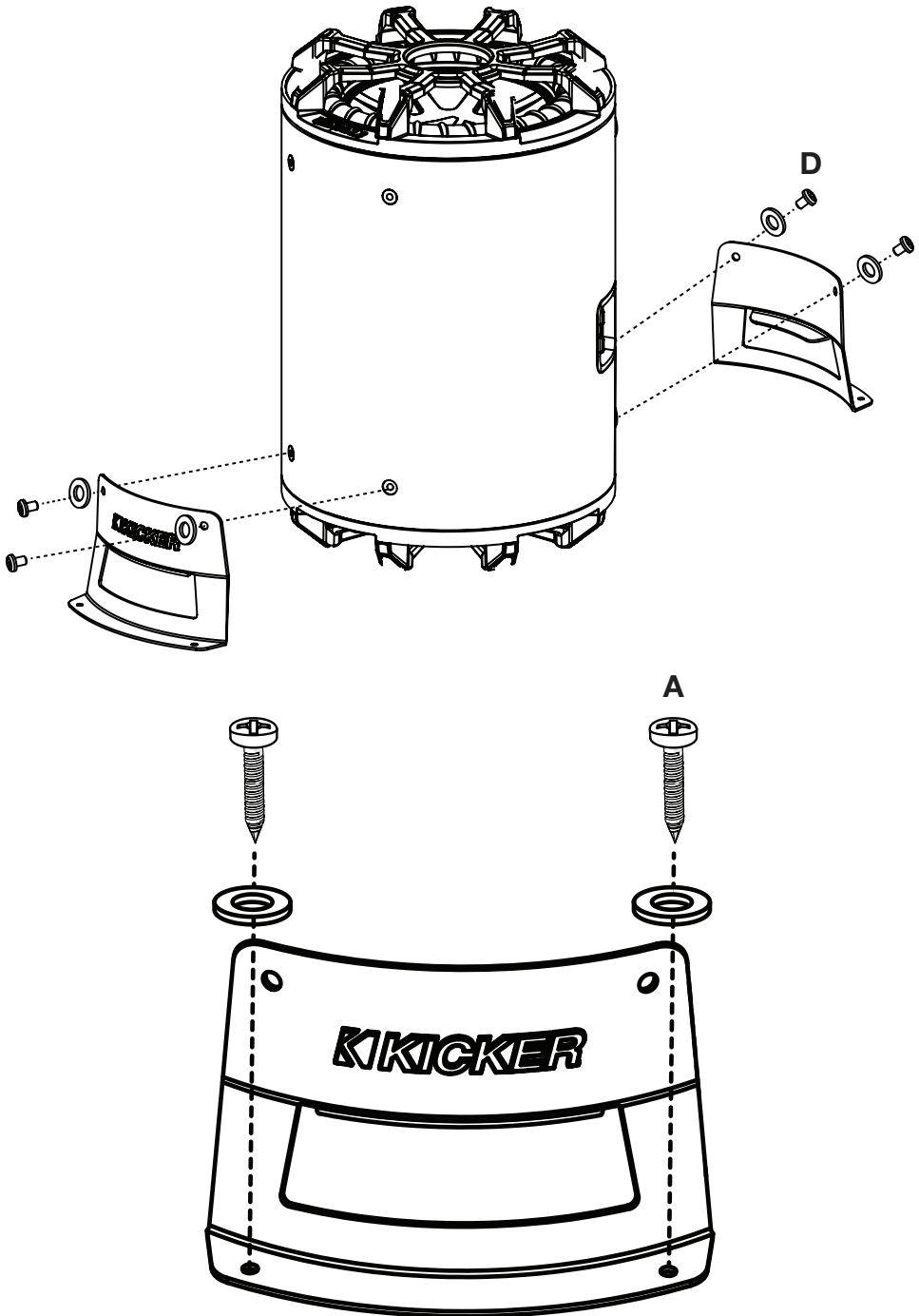

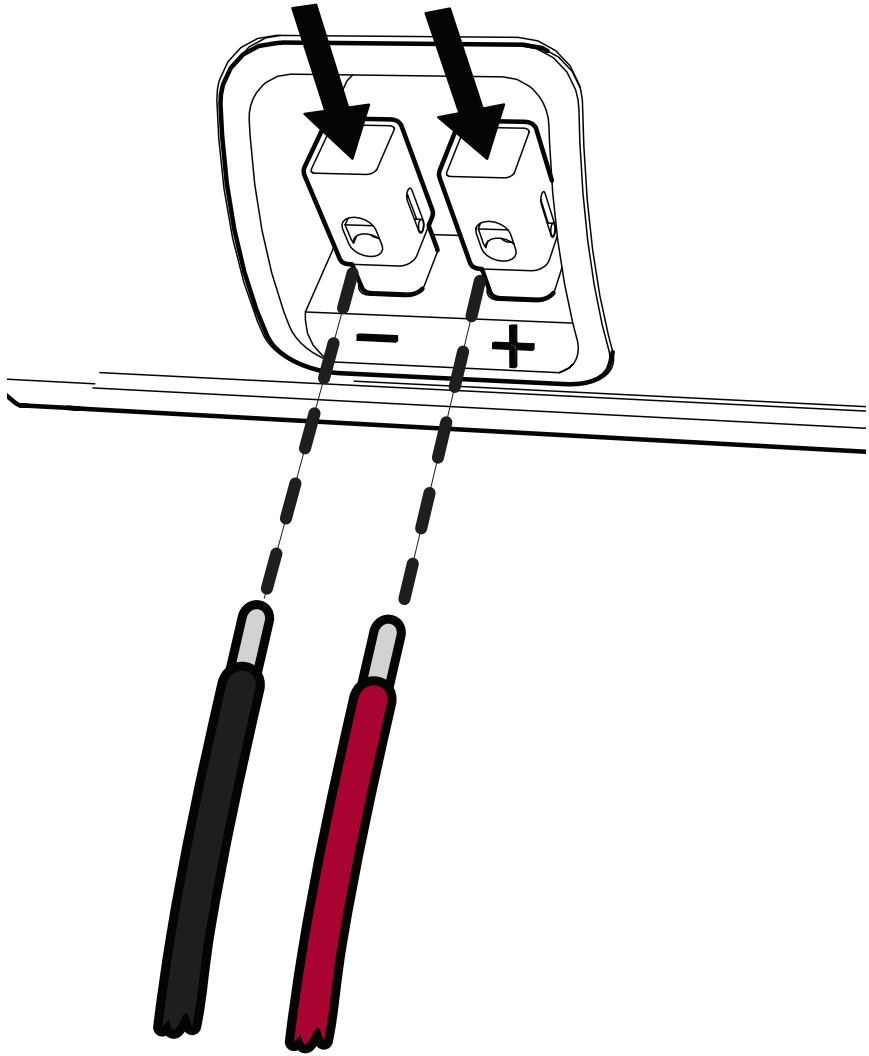

to amplifier  
amplificador  
verstärker

## **SPECIFICATIONS**

<b>Model</b>	<b>CWTB8</b>	<b>CWTB10</b>
Rated Impedance [ $\Omega$ ]	2 or 4	2 or 4
Sensitivity [1W, 1m]	84.4 dB	85.7 dB
Continuous Power Handling [Watts RMS]	300	400
Frequency Response [Hz]	30–500	25–500
Enclosure Diameter [in., cm]	8-1/2, 21.6	10-5/8, 27
Enclosure Depth [in., cm]	12-7/8, 32.8	16-9/16, 42.1
Enclosure Height (hor. mount) [in., cm]	8-3/4, 22.2	10-15/16, 27.7
Enclosure Height (vert. mount) [in, cm]	13-7/16, 34.1	17-1/16, 43.4

WARNING: KICKER products are capable of producing sound levels that can permanently damage your hearing! Turning up a system to a level that has audible distortion is more damaging to your ears than listening to an undistorted system at the same volume level. The threshold of pain is always an indicator that the sound level is too loud and may permanently damage your hearing. Please use common sense when controlling volume.

IMPORTANT SAFETY WARNING – PROLONGED CONTINUOUS OPERATION OF AN AMPLIFIER IN A DISTORTED OR CLIPPED MANNER CAN CAUSE YOUR AUDIO SYSTEM TO OVERHEAT, POSSIBLY CATCHING FIRE AND RESULTING IN SERIOUS DAMAGE TO YOUR COMPONENTS AND/OR VEHICLE.