



**ADVENTURE
FURTHER®**

**KC FLEX™ ERA 3
TRIM | LENS + O-RING**

INSTALLATION INSTRUCTIONS

IMPORTANT:

Please read all instructions before beginning installation. These guidelines are provided in good faith to help prevent any issues arising from errors during installation. The manufacturer of this product shall not be held responsible for any user actions taken or not taken during installation. There are many details of the installation that are assumed to be general mechanical knowledge to experienced installers; which are not detailed in these instructions. These installation guidelines are intended to serve as professional recommendations and are not as a step-by-step, fail-safe installation checklist. Selection of an experienced installer is the sole responsibility of the project owner.

STEP BY STEP INSTALLATION INSTRUCTIONS

IT IS HIGHLY RECOMMENDED THAT ALL SERVICING OF LED MODULES OCCUR OFF THE VEHICLE AND ON A CLEAN, FLAT SURFACE.

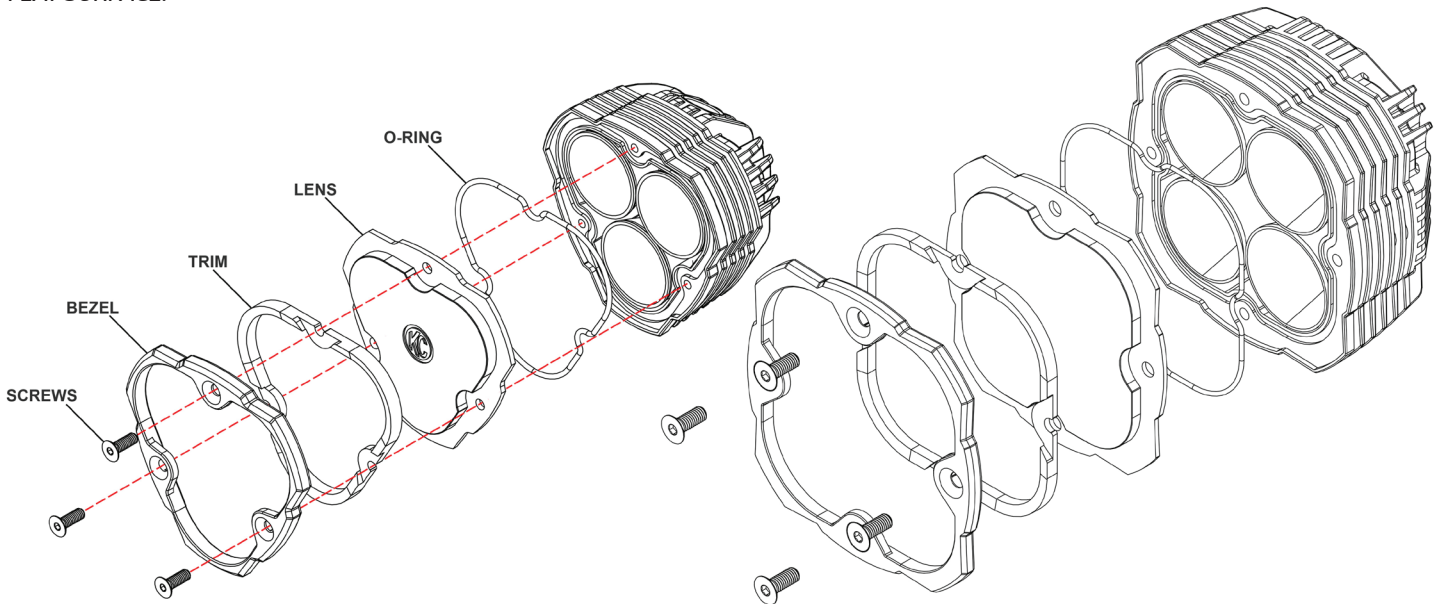

TRIM INSTALLATION:

1. Begin by using a 2.5 Hex/Allen Key to remove the M4 Flat Socket Cap Screws.
2. Remove BEZEL & TRIM from the assembly ONLY, leaving the LENS & O-RING in place.
3. Re-place the TRIM by seating it atop of the LENS.
4. Re-place the BEZEL over the TRIM.
5. Remove and Re-apply (Blue) Lock-Tite onto the screws.
6. Hand-tighten the M4 Flat Socket Cap Screw, evenly distributing the pressure.

Torque the Screws to 6.5lbf.in (7.5kgf.cm)

LENS + O-RING INSTALLATION:

1. Begin by using a 2.5 Hex/Allen Key to remove the M4 Flat Socket Cap Screws.
2. Remove BEZEL, TRIM, LENS + O-RING from the assembly.
3. Place 'new' O-RING in side the O-Ring Groove in Housing.
4. Place LENS atop the O-RING with the correct logo positioning.
5. Re-place the TRIM over the LENS.
6. Re-place the BEZEL over the TRIM.
7. Remove and Re-apply (Blue) Lock-Tite onto the screws.
8. Hand-tighten the M4 Flat Socket Cap Screw, evenly distributing the pressure.

Torque the Screws to 6.5lbf.in (7.5kgf.cm)



ADVENTURE
FURTHER®

2-LIGHT, 3-POLE, 40A RELAY (160W) WIRE HARNESS

INSTALLATION INSTRUCTIONS

IMPORTANT:

Please read all instructions before beginning installation. These guidelines are provided in good faith to help prevent any issues arising from errors during installation. The manufacturer of this product shall not be held responsible for any user actions taken or not taken during installation. There are many details of the installation that are assumed to be general mechanical knowledge to experienced installers; which are not detailed in these instructions. These installation guidelines are intended to serve as professional recommendations and are not as a step-by-step, fail-safe installation checklist. Selection of an experienced installer is the sole responsibility of the project owner.

STEP BY STEP INSTALLATION INSTRUCTIONS

Parts Included: (1) Wire Harness, (1) Switch, (1) Relay, (6) Wire Ties

1. Mounting Your Lights:

After choosing a location to mount your lights, install and loosely tighten before installing the wire harness.

2. Wiring Your Lights:

Before starting, make sure to remove the 3A fuse in-line to the switch and relay for safety.

1. Begin by routing the KC wire harness safely from the battery (or power source), away from any moving parts and connect the lights to the harness.
2. Next, route the three switch leads (spade connectors) toward the desired switch location. To install the switch, drill a 3/4" hole in the desired location to press the switch into. (**Note:** Do not install switch until you have the switch wires routed to the switch location, and then attach the switch wires accordingly before pressing the switch into the mounting hole). Connect the switch wires as follows: **WHITE** to Terminal-3 behind (=) indicator on switch, **YELLOW** to Terminal-2 (center), and **GREEN** to Terminal-1 behind (-) indicator on switch.
3. Mount the Relay close to the battery with blades facing down (sheet metal screw provided). Connect the Yellow Power lead (with ring terminal) to the (+) Positive side of the battery. Connect the Black Ground lead (with ring terminal) to the (-) Negative side of the battery or chassis ground.

3. Connect & Test:

After the harness has been secured and the Power & Ground properly connected. Re-install the removed 3A fuse and the relay. Test the lights by toggling both Low (-) and High (=) on the Rocker Switch.

