



A Division of Thiessen Products, Inc.

INSTRUCTION SHEET FOR TOOL No.786

CRUISE DRIVE (LATE H-D 6 SPEED TRANS) MAIN CASE SEAL INSTALLER

H-D's new 6 speed transmission is a very stout piece of engineering, using some of the best bearings made. These main case bearings are of such high precision that you must be very gentle when working with them. For this design JIMS has developed a seal installer that is used as a driver style and not a pushing or pulling type that can damage these bearings. This new tool installs the main seal without applying any stress to the new precision bearings, or new seals. This tool will also install seal No. **12074** to the correct depth.

No. **786** Use on all 6 speed Cruise Drive 2006 to present

Caution: Before installing any new parts, you and only you are responsible to make sure all components are within serviceable wear limits.

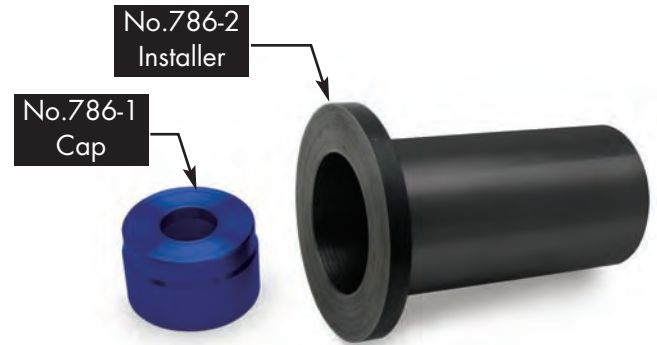

**NOTE: PLEASE READ ALL INSTRUCTIONS COMPLETELY BEFORE PERFORMING ANY WORK!
IF YOU DO NOT KNOW WHAT YOU ARE DOING, DO NOT DO IT!**

No information in this instruction sheet pertaining to motorcycle repair is represented as foolproof or even altogether safe. Even something safe, done incorrectly or incompletely can and will backfire. You and only you are responsible for the safety of your repair work and for understanding the application and use of repair equipment, components, methods and concepts.

Each and every step this tool is designed to do must be carefully and systematically performed safely by you. All information listed in this instruction sheet has been tested, re-tested and used daily in JIMS® Research and Development Department.

ALWAYS WEAR SAFETY GLASSES OR OTHER FACE AND EYE PROTECTION SUCH AS FULL FACE SHIELD. JIMS® IS NOT RESPONSIBLE FOR DAMAGE, INJURY, OR YOUR WORK. JIMS® IS NOT RESPONSIBLE FOR THE QUALITY AND SAFETY OF YOUR WORK.

TOOLS TO PERFORM THIS SERVICE

1. Service manual for the year and model you will be repairing.
2. Parts manual for the year and model you will be repairing.
3. A medium size brass hammer. JIMS No. **1080** or equivalent.

Installing new seal

1. Apply a small amount of Trans lube (the same lube you are using in the transmission) to the sealing surfaces of new seal. Also apply lube to the O.D. of No. **786-1** cap.
2. Gently place Cap No. **786-1** over mainshaft and over the end of main drive gear until it stops.
3. Pack the inside of new seal with grease in the groove with garter spring to prevent the spring from popping off when installing seal.
4. Gently slide new seal with the garter spring facing the Trans case over cap No. **786-1** and up to its bore. **See Fig 1.**
5. Next gently place Tool No. **786-2** over main shaft and up to new seal. With your brass hammer gently tap seal into its bore until it is making contact with trans case. **See Fig 1.**

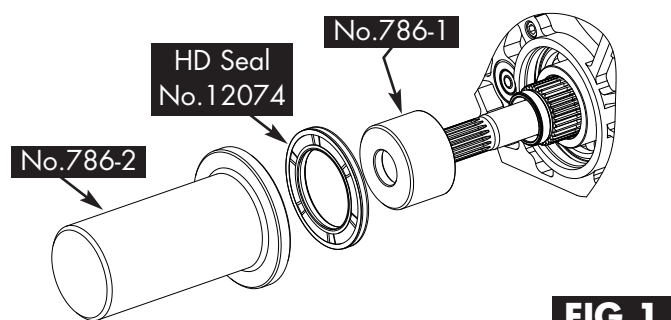

FIG 1

Performance Parts For Harley-Davidson Motorcycles