



A Division of Thiessen Products, Inc.

INSTRUCTION SHEET FOR No. 5468 & 5469

THE JIMS FORCEFLOW CYLINDER HEAD COOLER DESIGNED FOR 2017 - PRESENT TOURING MILWAUKEE 8 MODELS

NOTE: These instructions show the installation of this product on 2017 H-D M8 Touring Models. On other H-D Milwaukee 8 models you need to follow the same steps for installation. There are minor differences on other years or models installation. It is highly recommended that you use the correct H-D Service Manual for reference in this installation. Refer to last page for parts list and for bubble reference callouts.

OPERATION AND OPTIONS:

The **FORCEFLOW CYLINDER HEAD COOLER** comes with a thermostat that actuates at approximately 140°F along with an off switch. It is the installer's option to use the thermostat system we have designed and where we recommend you locate it. If you choose to relocate the thermostat, it is your responsibility to mount it properly. If you choose not to use the thermostat, it is your responsibility to safely disconnect this system. Since JIMS has not tested this product with optional changes or locations, JIMS cannot back any warranty issues in this application.

IMPORTANT SAFETY ISSUES:

We have designed the **FORCEFLOW CYLINDER HEAD COOLER** to operate only when the ignition system is turned on by the operator as a safety factor. **DO NOT MODIFY WIRING TO ALLOW THE COOLER TO OPERATE WITH THE IGNITION IN THE OFF POSITION.**

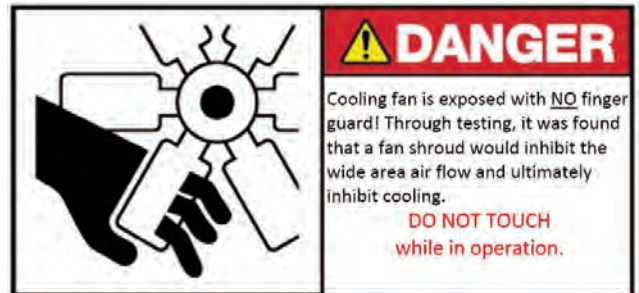

FIG. 1

Warning: KEEP HANDS AWAY FROM MOVING FAN BLADE!

JIMS R&D Department tested the **FORCEFLOW CYLINDER HEAD COOLER** with a protective shroud around the fan blade and found that it cooled better without a shroud. So with that said do not get your hands, etc. near the blade when in operation. **See Fig 1.**

NOTE: PLEASE READ ALL INSTRUCTIONS COMPLETELY BEFORE PERFORMING ANY WORK! IF YOU DO NOT KNOW WHAT YOU ARE DOING, DO NOT DO IT!

No information in this instruction sheet pertaining to motorcycle repair is represented as foolproof or even altogether safe. Even something safe, done incorrectly or incompletely can and will backfire. You and only you are responsible for the safety of your repair work and for you understanding the application and use of repair equipment, components, methods and concepts.

Each and every step this tool is designed to do must be carefully and systematically performed safely by you. All information listed in this instruction sheet has been tested, re-tested and used daily in JIMS® Research and Development Department.

ALWAYS WEAR SAFETY GLASSES OR OTHER FACE AND EYE PROTECTION SUCH AS FULL FACE SHIELD. JIMS® IS NOT RESPONSIBLE FOR DAMAGE, INJURY, OR YOUR WORK. JIMS® IS NOT RESPONSIBLE FOR THE QUALITY AND SAFETY OF YOUR WORK.

**CAUTION: WEAR SAFETY GLASSES OVER YOUR EYE'S.
SEE JIMS® CATALOG FOR HUNDREDS OF TOP QUALITY PROFESSIONAL TOOLS.
THE LAST TOOLS YOU WILL EVER NEED TO BUY.**

Performance Parts For Harley-Davidson Motorcycles



INSTRUCTION SHEET FOR No. 5468

TOOLS AND SUPPLIES RECOMMENDED FOR INSTALLING THE FORCEFLOW CYLINDER HEAD COOLER.

1. Common box end wrenches, ratchet, and socket set.
2. Quality ft-lb torque wrench.
3. Quality in-lb torque wrench
4. Box cutter, knife or diagonal cutter to modify the wiring trough.
5. The correct H-D Service Manual for year and model you're working on.
6. Blue Threadlocker.
7. Assorted zip ties.

PREPARATION AND INSTALLATION

1. Remove seat, and disconnect negative battery cable and remove maxi fuse per H-D Service Manual.

2. Remove fuel tank, saddlebags, and side covers per H-D Service Manual.

Note: The compact design of JIMS FORCEFLOW CYLINDER HEAD COOLER necessitates using a small horn inside the cover for function and aesthetics. Due to the small size of the horn, the tone is not as low as the stock horn. If you are unsatisfied with the tone of the horn, you can relocate the stock horn and use both horns simultaneously. The mounting location will depend on the year and model of the motorcycle. Some users have relocated the stock horn, without its cover, under the seat or in the nacelle or fairing. The installer must choose the best mounting location for each specific model.

3. Assemble the FORCEFLOW CYLINDER HEAD COOLER. Install the cooler assembly on the two rubber isolator mounts. Slide the threaded stud through the No 5473-1 Fan and backing plate assembly holes and place the No 5474 Logo Plate over the threaded studs, hand tighten the two No 5427 chrome acorn nuts with No. 2014 washers from kit to secure assembly. Use Blue Threadlocker on the acorn nuts. **See Fig 2**

Slide the two threaded studs on the No. 69712-92A vibration isolators through the short flange on the No. 5476 mounting bracket with the short flange pointed upwards. Attach with 2 No. 5470 5/16-18 Nylock nuts.

See Fig 3

4. Tighten the acorn nuts and the Nylocks to 12-15 ft-lbs.
5. Remove horn assembly with attached bracket per H-D Service Manual. Set aside the mounting bolts to use for the cooler installation.
6. Remove the top wire harness trough cover to gain access and to place the cooler wiring harness into.
7. Using a box cutter, knife or diagonal cutter cut a notch out of the left side of the plastic harness trough.



FIG. 2



FIG. 3



FIG. 4



A Division of Thiessen Products, Inc.

INSTRUCTION SHEET FOR No. 5468

The notch should be positioned directly above the normal horn position. When cutting the notch, be very careful not to cut any existing wiring. The notch should be an approximately 1" square cutout without any rough edges. Round off any sharp edges to prevent the wiring harness from being damaged. **See Fig 4 & Fig 5**

8. Locate the main wire harness No. **5463** supplied with FORCEFLOW CYLINDER HEAD COOLER and position it across the top frame rail on top of the existing wiring harness. You need to lay the cooler harness on the left side of the harness trough so that you have the thermostat with bracket and white connector near the original horn location. **See Fig 6**. To position it correctly you need to have the thermostat drop down to the old horn position. You need to have about a 9" lead hanging out of the harness trough or main wiring harness area as shown to connect the horn and cooler wiring.

**FIG.5**

9. Remove the left front cylinder rocker box screw.
10. Locate the thermostat with mounting bracket on the No. **5463** wiring harness hanging down between the cylinders. Mount the bracket No. **5434** with thermostat using No. **5478** hex head bolt, No. **1683** washer, and spacer No. **5477** to the rocker box cover as shown. Torque to 120-140 in-lbs using Blue Threadlocker. At this location the thermostat will activate the fan at approximately 140°F. The thermostat mount must be in contact with the rocker box for proper operation. **See Fig 7**.

**FIG.6**

11. Connect the wiring from the cooler housing to the harness before mounting the FORCEFLOW CYLINDER HEAD COOLER housing on the motorcycle. We suggest you have another person hold the FORCEFLOW CYLINDER HEAD COOLER housing while you connect to the horn wiring harness.
12. Connect the bikes two existing original horn connectors to the light blue plastic spade connectors coming from the housing backing plate rubber grommet. It does not matter what blade goes to which wire. **See Fig 8**

Note: For added insulation from weather, position existing shrink wrap and heat as required before doing the final positioning. You may add more shrink wrap if necessary.

13. Install the FORCEFLOW CYLINDER HEAD COOLER on engine. Place the mounting bracket holes over the corresponding horn mount holes on heads and insert the horn mounting bolts with washers. Hand tighten. The mounting bracket is provided with slots to allow minor adjustment of the FORCEFLOW CYLINDER HEAD COOLER. Position the FORCEFLOW CYLINDER

**FIG.7**

Performance Parts For Harley-Davidson Motorcycles



A Division of Thiessen Products, Inc.

INSTRUCTION SHEET FOR No. 5468

HEAD COOLER until the fan is centered between the cylinders and tighten the bolts to 35-40 ft/lbs.

See Fig 9

14. Locate the other wire coming out of the housing grommet. It has a four pin male white plastic connector that you connect to the cooler harness hanging down from the motorcycles main harness area.
16. Connect the two white plastic connectors together. They will only connect when positioned correctly. **See Fig 10**
17. Carefully position the horn and power wires in the area behind the FORCEFLOW CYLINDER HEAD COOLER assembly and up to the main wire trough. **See Fig 11**

Note: The wire harness needs to be routed over the top of the FORCEFLOW CYLINDER HEAD COOLER mount, not under. This routing will help keep wiring off cylinders when tie wrapped to the mounting bracket mount in final running position. The other end of the cooler harness with the relay, positive wire, Deutsch connector, & black negative eyelet should be routed back to the battery area.

Note: It is very important and is the installer's responsibility to route and anchor harness wiring away from the cylinders and fan blades. If not done correctly, electrical shorts causing fire, further damage, or bodily harm may occur. If you are not sure about this, take it to a qualified professional. JIMS cannot be responsible for your safety or workmanship.

Caution: *Always check the 3 cover screws for proper torque when installing the FORCEFLOW CYLINDER HEAD COOLER assembly. If you remove the cover, be sure to apply blue threadlocker to the screws and torque to 90 inch pounds.*

18. Check the wiring coming out of the back of cooler housing and take out any slack by lightly pulling on harness going up to the FORCEFLOW CYLINDER HEAD COOLER bracket and up to the notched out area of the harness trough. Do a visual check inside the cooler housing to see that all wiring has clearance. No wiring can come in contact with the fan blade or cylinders. Reposition any extra slack in the harness back to the battery area. Route wiring over mounting bracket to trough area and secure with zip ties for the final operating position.

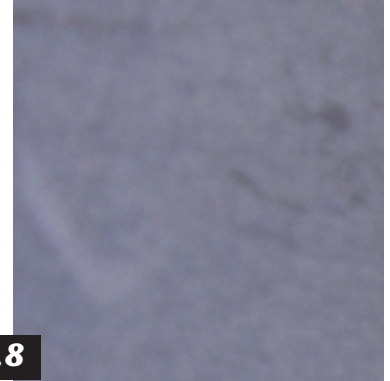

FIG. 8



FIG. 9



FIG. 10

CAUTION: WEAR SAFETY GLASSES OVER YOUR EYE'S.
SEE JIMS® CATALOG FOR HUNDREDS OF TOP QUALITY PROFESSIONAL TOOLS.
THE LAST TOOLS YOU WILL EVER NEED TO BUY.

Performance Parts For Harley-Davidson Motorcycles

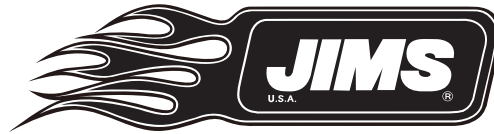

A Division of Thiessen Products, Inc.

INSTRUCTION SHEET FOR No. 5468

Caution: *DO NOT zip tie On/Off switch wires too tight! They need some slack to move so they don't break at the switch.*

See Fig. 12

After the FORCEFLOW CYLINDER HEAD COOLER is installed, take your finger and spin the fan blade to check for clearance. **See Fig. 13**

19. Tuck the cooler harness into the left side of the harness trough. Reinstall the wire harness upper trough cover back in its normal position per H-D Service Manual.
20. The power connector socket is not installed into the Deutsch connector. A moisture guard seal is on Deutsch connector, and only one position should be open on the 6 way connector. Insert the socket terminal into position 5 on the Deutsch connector, install the wedge lock into the connector. **See Fig. 14.**

Route the Deutsch connector harness down to the left side enclosure and plug into the 6 place accessory connector. **See Fig 15 and 16**

Note: If your vehicle does not have a Deutsch connector, use this wire to tap into any ignition accessory circuit.

21. Locate the negative battery cable and connect the negative wiring eyelet to it. Mount negative battery cable to the battery post as shown. **See Fig 17**
22. Pull aside the cooler wire harness relay section and install the ECM caddy cover as per H-D Service Manual. After the caddy cover is in place, lay the relay wire harness section right along the side of the frame as shown. You can anchor it if you like. **See Fig 18**
23. Reinstall the fuel tank, fuel lines, maxi-fuse, saddlebags and seat per H-D Service Manual.
24. Now you need to take a test ride and get the motor warmed up. Position cooler switch in the on position (left position is "OFF" and right is "ON"). The easiest way to check temperature is with an infrared thermometer. When your engine heats up enough to bring the top rocker box to approximately 140°F the cooler should turn on. Do not use a heat gun or any other heat source other than running the engine to get the thermostat hot enough to turn fan on. You will destroy the thermostat. If you find your fan motor is not turning on, move the toggle switch to the other position and see if that starts the fan motor.



FIG. 11

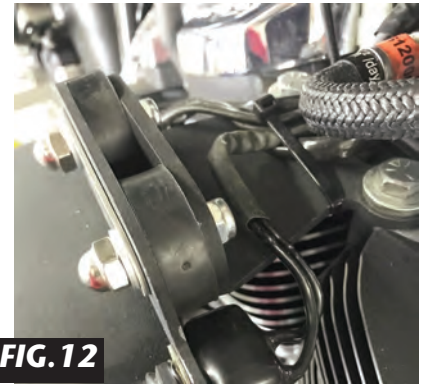

FIG. 12



FIG. 13

Performance Parts For Harley-Davidson Motorcycles



A Division of Thiessen Products, Inc.

INSTRUCTION SHEET FOR No. 5468

Note: If you're a Dealer Service Dept. installing this product for a customer please forward the JIMS Warranty Card to the customer or end user when completing service and advise to complete and mail in.

6 MONTH WARRANTY

JIMS will repair or replace at our option any product found to be defective in materials or workmanship for six (6) months from date of purchase. This warranty does not cover items damaged by accident, misuse, or neglect. Any implied warranties are expressly excluded, and JIMS shall not be liable for any loss of product use, or other consequential or incidental costs incurred by the user of our tools.



FIG. 14

FOR WARRANTY

All returns for warranty must be authorized by the sales department before returning product.

WARNING!!!

KEEP HANDS AND ALL OBJECTS CLEAR OF THE SPINNING FAN BLADE WHENEVER FORCEFLOW CYLINDER HEAD COOLER UNIT IS SWITCHED TO THE "ON" POSITION.



FIG. 15



FIG. 16



FIG. 17

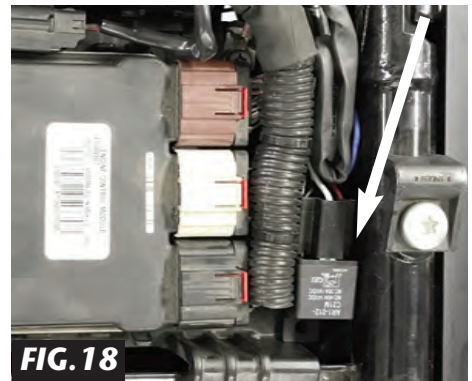
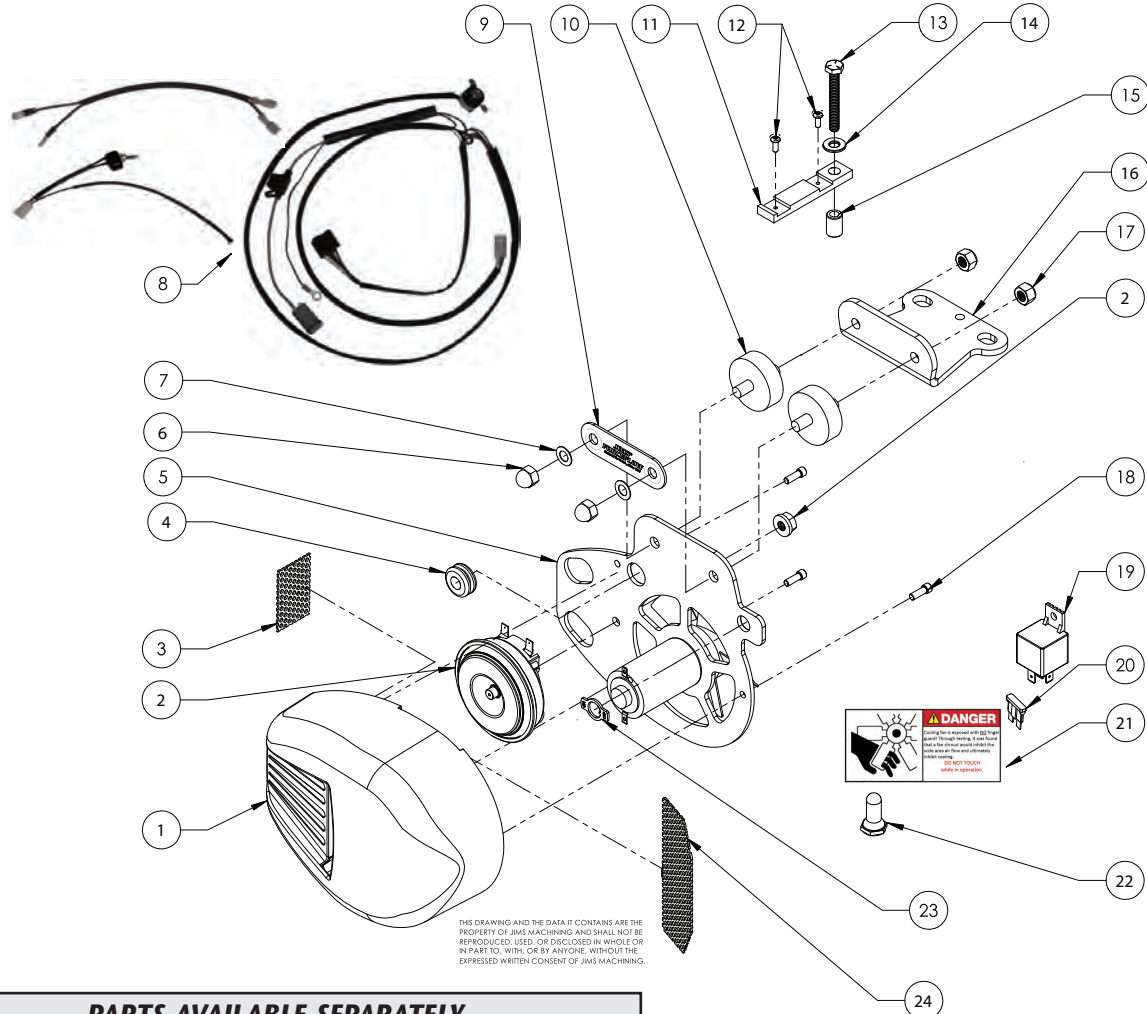

FIG. 18



A Division of Thiessen Products, Inc.

INSTRUCTION SHEET FOR No. 5468



THIS DRAWING AND THE DATA IT CONTAINS ARE THE PROPERTY OF JIMS MACHINING AND SHALL NOT BE REPRODUCED, USED, OR DISCLOSED IN WHOLE OR IN PART TO, WITH, OR BY ANYONE, WITHOUT THE EXPRESSED WRITTEN CONSENT OF JIMS MACHINING.

PARTS AVAILABLE SEPARATELY			
QTY	NO.	DESCRIPTION	PART NUMBER
1	1	COVER, CYLINDER COOLER, BLACK	5461-1
1	2	HORN, ROOT, W/FLANGE NUT	5410
1	3	SCREEN, FRONT	5399
1	4	GROMMET, 3/8" ID X 1/8" PANEL	5418
1	5	FAN AND BACKING PLATE ASSY, BLACK	5473-1
2	6	NUT, NICKEL, ACORN 5/16-18	5427
2	7	FLAT WASHER, 5/16 SAE	2014
1	8	FORCE FLOW COMPLETE WIRE HARNESS	5474
1	9	LOGO PLATE, SCREENED	5475
2	10	VIBRATION ISOLATOR, HD	69123-92A
1	11	MOUNT, THERMOSTAT	5434
2	12	SCREW, 6-32 X 3/16 BUTTON HEAD	5440
1	13	"1/4-20 X 2" HEX HEAD BOLT	5478
1	14	WASHER, 1/4", SAE	1683

1	15	"1/4" SPACER, 5/8" LONG CHROME	5477
1	16	MOUNTING BRACKET, PAINTED AND LASER	5476
2	17	5/16-18 NYLOCK NUT	5479
3	18	SCREW, 10-32 X 1/2" SHCS, BLACK	1294
1	19	RELAY, FORCE FLOW COOLER	5422
1	20	AMT, 15 AMP FUSE	5432
1	21	TAG WITH WARNING STICKER	5445
1	22	BOOT, SWITCH, BLACK	5417
1	23	ON/OFF SWITCH PLATE	5455
1	24	SCREEN, SCOOP	5411
1	25	WHITE CARTON, 12" X 12" X 6" (NOT SHOWN)	5425
1	26	FOAM SET, FORCEFLOW (NOT SHOWN)	5424
1	27	BOX LABEL (NOT SHOWN)	5446
1	28	WARRANTY CARD (NOT SHOWN)	5454
1	29	INSTRUCTION SHEET	5468-IS

Performance Parts For Harley-Davidson Motorcycles