



INSTALLATION INSTRUCTIONS

Part # 751-FP2300

IMPORTANT INFORMATION

This Jagg oil cooler must be installed following these instructions. Read the easy-to-follow instructions fully prior to starting the installation of the oil cooler kit. Correct installation is the only way to ensure proper operation of the oil cooler kit.

QTY.	KIT CONTENTS
1	Jagg FP2300 Fan-assisted oil cooler assy.
1	Jagg 4700 offset oil filter adapter assembly
2 ft	Jagg 30R7spec black oil hose
4	7/8" black worm-drive hose clamps
1	Jagg anti-rotation device
2	Bolts: 10-24 x 1-3/8" cap head, black
1	Stock-to-Jagg oil filter nipple
1	Jagg automatic fan switch, 190°F
1	Street-tee pipe fitting, NPT1/8 male to 2xNPT1/8 female
29"	Wiring harness for WeatherTek fan
30"	Convuluted wire cover
3	Plastic zip-ties
2	1/4-20x3/4" button head bolt
2	1/4-20 hex nut
2	1/4" flat washer
2	Regulator riser brackets

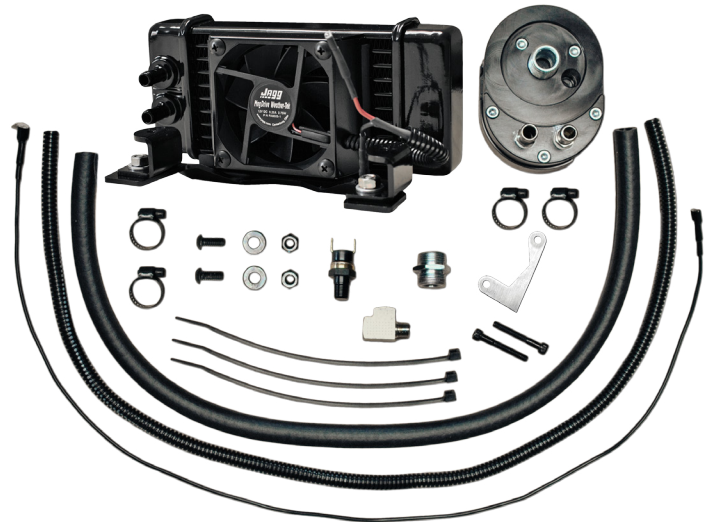

TOOLS NEEDED

Strap wrench or oil filter removal tool	5/32" Allen wrench
Phillips head screwdriver	1/4" Allen wrench
7/8" socket	7/16" Allen wrench (if removing a stock H-D oil cooler)
1" deep-well socket	Hose cutter or sharp knife
7/16" deep-well socket	Teflon pipe sealant (e.g., Loctite 592)
Needle-nose pliers	Dielectric grease

BASIC SYSTEM INSTALLATION GUIDELINES

- Route oil hose to avoid any hot surfaces or moving parts. Ensure all bends are smooth, with no sharp turns that may restrict oil supply to the engine.
- Oil cooler is designed to mount as detailed in these instructions. Any modifications may lead to decreased performance or item failure.
- When cutting oil hoses, always use a sharp knife, single-edge razor blade, or hose cutter. Make a straight, clean cut at 90° to the oil hose. This will ensure a proper fit where the oil hose attaches to its connection.
- Over tightening hose clamps may cause oil leaks.

CAUTION: ALLOW MOTORCYCLE TO COOL BEFORE ATTEMPTING INSTALLATION OR RISK SERIOUS INJURY.

Oil cooler plumbing

The Jagg offset oil filter adapter is used to access the oil supply for the installation of a Jagg oil cooler. The adapter features a built-in automatic thermostat to allow oil to by-pass the oil cooler, simply being filtered and returned to the engine, until the bike warms up to operating temperature. Once the bike reaches operating temperature, the thermostat will close the adapter's by-pass hole, sending hot, filtered oil to the oil cooler, and delivering cool, clean oil to the engine.

Part 1: Installing the offset oil filter adapter

1. Remove spin-on oil filter, and clean the filter mounting surface thoroughly.
2. If removing and upgrading a factory Harley-Davidson oil cooling system, uninstall the stock oil filter adapter by removing the flanged oil filter nipple that holds the adapter in place using a 7/16" Allen wrench. Locate the stock-to-Jagg oil filter nipple (shown at right) included in the kit. Install by inserting the orange-painted end into the port where the stock oil filter stem was removed. Using a 7/8" socket, tighten until the hex is flush against the oil filter housing.
3. Disassemble the Jagg offset oil filter adapter by removing the five Allen head bolts from the front face of the adapter using a 5/32" Allen wrench. Then remove the front half of the adapter (the portion with hose fittings attached).
4. With the longer/offset end of the adapter at the top, place the back half of the adapter (the portion with the flat rubber o-ring) over the threaded oil filter stem and tighten the included 1" lock-nut to finger-tight. The adapter's flat sealing rubber o-ring should face in, toward the stock oil filter housing, and be free of debris. (Do not apply oil to this o-ring.)
5. Locate part 4600AR-C Jagg anti-rotation device. Installation of this device will ensure the Jagg 4700 offset oil filter adapter will not



*Stock-to-Jagg
oil filter nipple*

rotate during future oil filter removal.

6. Place the anti-rotation device against the face of the front half of the adapter in the orientation shown below. The device affixes to the two lower holes on the right side and center of the adapter.
7. Insert the two black 10-24 Allen head bolts included with the anti-rotation device through the appropriate holes on the oil filter adapter.
8. Place the front half of the adapter over the already-installed back half and rotate the entire adapter to the left until the anti-rotation device makes contact with the engine case.
9. Remove the front half of the adapter and hold the back half of the adapter in its current orientation. Using a 1" deep-well socket securely tighten the 1" lock-nut so the back half of the adapter will not rotate and the sealing o-ring is tight against the stock filter mount. This may require a prying force applied against the adapter to allow tightening while retaining the chosen orientation.



*4600AR-C Jagg
anti-rotation device*

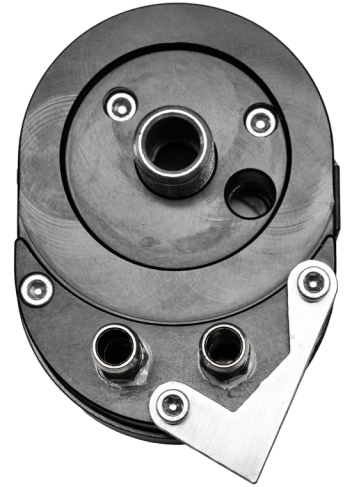

Anti-rotation device fitment

NOTE: On rubber-mounted engine models, allow adequate clearance to ensure that the adapter will not strike any object when the motor shakes.

Part 2: Installing the automatic fan switch

The Jagg WeatherTek fan operates via the included automatic fan switch. The automatic fan switch installs into the included street-tee pipe fitting to access hot oil



Automatic fan switch

flow from the oil filter adapter to activate the fan.

Oil flow from the adapter feeds the oil cooler from the fitting on the left side and returns to the fitting on the right side, as viewed from the front with the oil filter adapter fittings at the bottom.

- Using a 7/16" deep-well socket, remove the 3/8" push-on fitting from the left port of the oil filter adapter.
- Apply Teflon pipe sealant (e.g., Loctite 592) to the 1/8" male pipe threads on the fitting removed from the oil filter adapter.
- Install the pipe thread end of the removed fitting into female port #2 of the street-tee pipe fitting (shown below).

NOTE: 1/8" pipe threads should be installed to finger-tight, and then tightened an additional 2-to-2.5 turns.

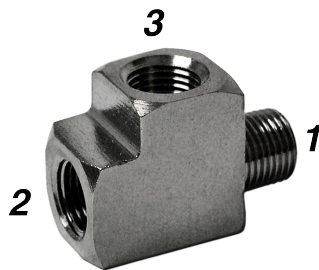

Street-tee pipe fitting

- Apply Teflon pipe sealant to the 1/8" male pipe thread on the #1 male port of the street-tee pipe fitting.
- Install the #1 male port of the street-tee pipe fitting into the left port of the oil filter adapter.

NOTE: It may be necessary to test fit the front half of the oil filter adapter to the motorcycle to determine the proper "clocking" orientation of the 1/8" female pipe port to ensure clearance of any obstruction. The final clocking position should be circa 7 o'clock relative to the front face of the oil filter adapter.

- Apply Teflon pipe sealant to the 1/8" male pipe thread on the automatic fan switch.
- Install the 1/8" male pipe thread end of the automatic fan switch into the #3 female port of the street-tee pipe fitting.
- Install AFM gasket onto the back half of the adapter.

CAUTION: AFM gasket should be applied dry. No additional gasket sealing compound is required. Ensure that the adapter halves are free of oil residue.

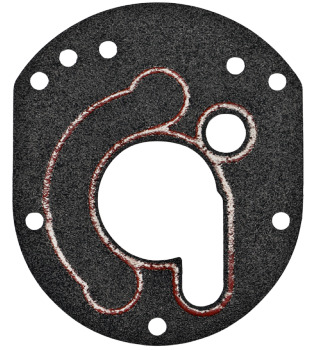

AFM gasket

- Place the front half of the adapter against the gasket and install Allen bolts loosely. If a thread lock compound is optional, please choose a medium strength and use it on the Allen bolts at this step.
- Evenly draw the two halves of the adapter together by gradually tightening the Allen bolts in an alternating criss-cross pattern (e.g., like tightening wheel lug nuts on a car).
- When the adapter halves have been evenly drawn together, firmly tighten the Allen bolts in the same alternating criss-cross pattern as the previous step.

SERVICE NOTE: Inspect adapter and screws for tightness at each oil filter change.

Part 3: Installing the mounting brackets

- Remove the oil cooler from the fan assembly and oil cooler mounting bracket. Retain M6x1.0x10mm bolts for reassembly.
CAUTION: If reinserting M6x1.0x10mm bolts into the oil cooler mounting bosses without the oil cooler mounting bracket, take care not to bottom out these bolts. Bottoming out can cause penetration of oil passageway and oil leak.
- Locate the voltage regulator on the motorcycle. Remove the nuts and washers from the voltage regulator mounting bolts and remove or reposition the voltage regulator to allow open access to the voltage regulator mounting bolts.

NOTE: Some models (generally 2005 and earlier) may have a "P" clip attached to the regulator foot on the air-cleaner side of the motorcycle. This "P" clip can be bent out

of the way of the installation of this kit or removed altogether.

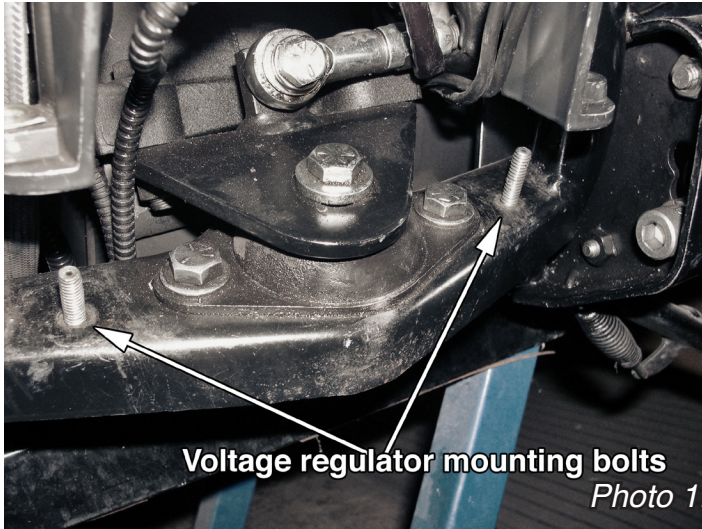

23. Using the 1/4-20x3/4" button head bolts included in the kit, install the voltage regulator riser brackets to the bottom of the voltage regulator mounting feet. The "open" side of the riser brackets should orient to face toward the horn side of the motorcycle when installed (to allow clearance for the oil hose).

TIP: Leave the riser brackets somewhat loose to allow for any necessary adjustment during the rest of the installation.

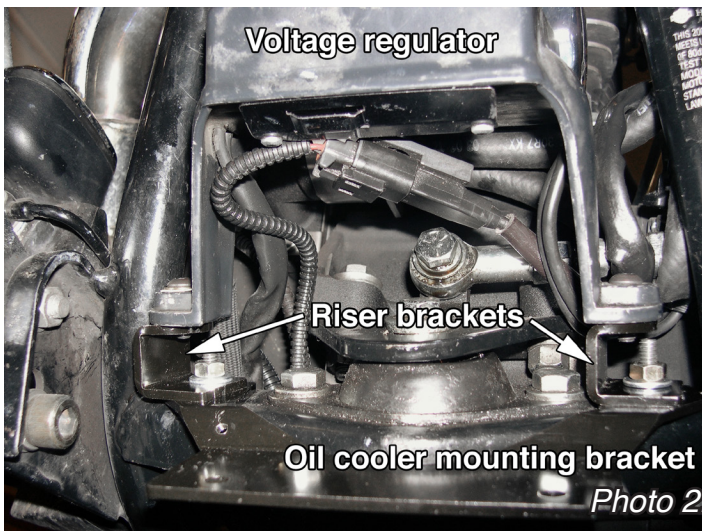

24. Install the oil cooler mounting bracket over the voltage regulator mounting bolts, taking care not to pinch any electrical wires.

25. Set the voltage regulator with riser brackets

installed down over the regulator mounting bolts and on top of the oil cooler mounting bracket installed in the previous step.

26. Use the 1/4" flat washers and the 1/4-20 nuts supplied in the kit to fasten and secure the riser brackets and oil cooler mounting bracket.

27. Fully tighten the 1/4-20x3/4" button head bolts holding the voltage regulator to the riser brackets.

Part 4: Fan wiring

28. Install the included convoluted wire cover over the fan wiring harness by inserting wiring into the split. If the wire cover is too long, then it may be trimmed with scissors.

29. Install the fan wiring harness by connecting the female disconnect onto either prong of the automatic fan switch.

30. Route the fan wiring harness under the right side (air cleaner side) of the motorcycle along the frame.

31. Locate the rear brake light switch under the frame and behind your right boot heel as you would sit on the motorcycle. Remove the connector from the "hot" side of the brake light switch.

32. Install the "piggyback" dual-connector end of the fan wiring harness onto the "hot" side of the brake light switch.

33. Reinstall the brake light switch connector onto the exposed prong of the "piggyback" dual-connector of the fan wiring harness.



TIP: A liberal coating of dielectric grease spread on the terminals before making electrical connections will help to prevent terminal connection corrosion.

34. Ensure that all installed wiring is clear of the exhaust pipe and use the zip-ties included in the kit to secure the connected fan wiring harness to the motorcycle's frame.



35. Install the fan power lead onto the remaining open prong of the automatic fan switch.

36. Using the #8-32x1/4" Phillips head grounding screw included in the kit, attach the fan ground lead wire's ring terminal to the oil cooler mounting bracket.

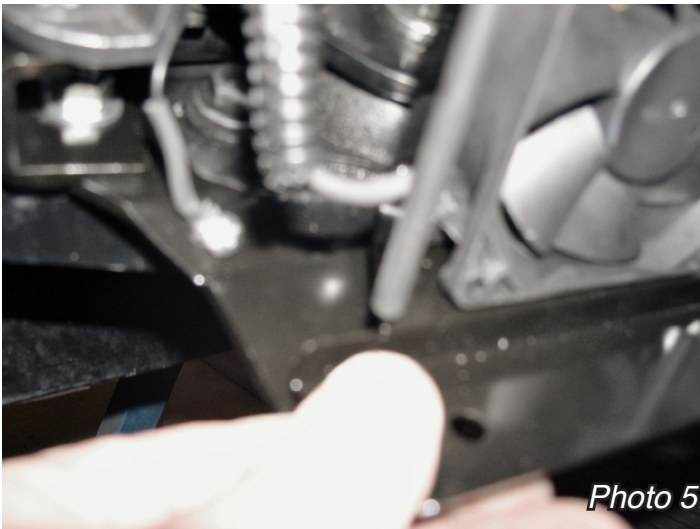

Part 5: Oil cooler mounting

37. Install the fan shroud assembly and oil cooler using the M6x1.0x10mm bolts removed earlier. Fasten securely.

TIP: Use of a medium strength vibration resistant thread locker is recommended for the installation of oil cooler to mounting bracket and regulator mounting bolts.

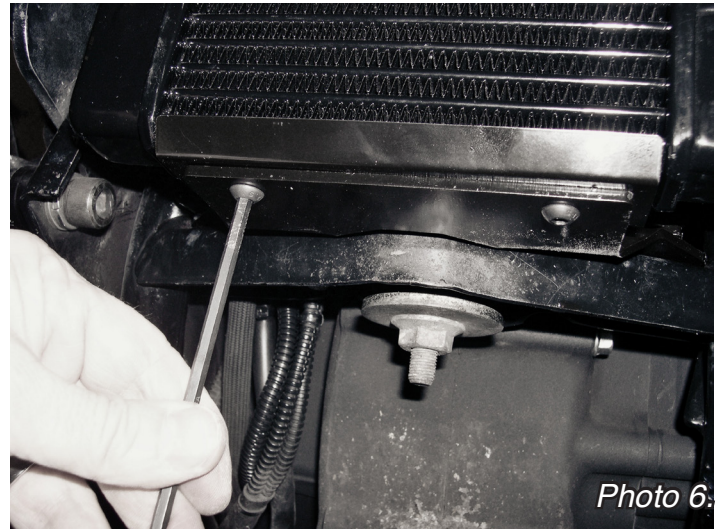

Part 6: Installing the oil lines

38. Cut the provided oil hose into two lengths and install the oil hoses onto the hose fittings on the oil cooler. Secure hose over the fittings with the 7/8" black hose clamps included in the kit so the hose cannot pull over the barb on the fitting. The flow orientation of the oil cooler is non-directional, so either hose fitting will allow proper flow as an inlet or an outlet.



TIP: Install 7/8" black hose clamps loosely onto hoses before installing hoses onto oil cooler nipples. A touch of oil on oil cooler nipples allows the hoses to push on easily.

39. Measure, cut, route, and attach the oil hoses to the oil filter adapter. Secure hose over the fittings using the 7/8" black hose clamps onto the oil filter adapter inlet and outlet as detailed in the previous step.

NOTE: It may be necessary to rotate hose clamps to ensure hose clamps do not interfere with oil filter installation.

CAUTION: Take care to make gentle bends in oil hose routing from oil cooler to adapter. Sharp bends may collapse under heat load and cause restriction to oil flow.

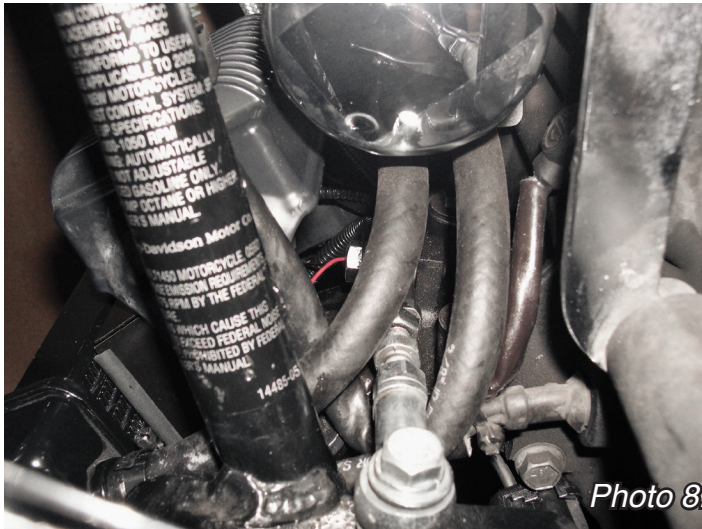

Photo 8.

40. Install oil filter onto the threaded stem of the oil filter adapter. Tighten per factory/service manual recommendations.

Part 7: Final inspection

41. Inspect the oil hoses to ensure there are no tight bends that may restrict oil flow and that they are not contacting any moving parts. If necessary secure the new hoses to the frame with plastic zip-ties.

42. Refill the engine with the correct amount and type of oil. Check the oil level per factory/ser-

vice manual recommendations.

43. Start the engine and let it idle. Check all oil hose connections for any leakage. Tighten any hose clamps that may be leaking.

NOTE: Over-tightened hose clamps may cut into oil lines and cause oil leaks.

44. After installation completion and engine warm-up, shut the engine down and recheck the oil level. Correct the oil level if necessary, but do not over-fill.

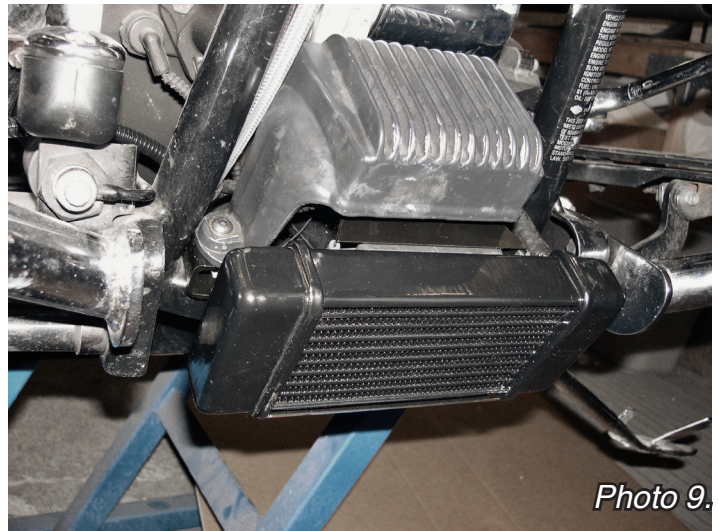

Photo 9.

SERVICE & UPGRADE ITEMS AVAILABLE	
PART NO.	DESCRIPTION
GK4600	Gasket service kit for Jagg offset oil filter adapter. Includes: AFM gasket and large o-ring for Jagg 4700 offset oil filter adapter
TS180	The TS180 automatic fan switch actuates at a lower temperature to turn on a fan sooner.
TS190	The TS190 automatic fan switch is a direct replacement for the fan switch included in the kit.
FA8025-1	Jagg WeatherTek magdrive fan. Direct replacement for the fan included in the kit.
21-SSN06-B	Stainless steel braided oil hose. High performance 3/8"(-06) Nitrile rubber oil hose with stainless steel braided jacket
08-0069	Oil filter strap wrench. Simply one of the easiest oil filter wrenches to use. Engineered to access oil filter for removal around almost any obstacle. Use with 3/8-inch drive ratchet extension. Takes up virtually no space in the toolbox or the saddlebag.