



INSTALLATION INSTRUCTIONS

Part # 750-1290

IMPORTANT INFORMATION

This Jagg oil cooler must be installed following these instructions. Read the easy-to-follow instructions fully prior to starting the installation of the oil cooler kit. Correct installation is the only way to ensure proper operation of the oil cooler kit.

QTY.	KIT CONTENTS
1	Jagg Lowmount Softail oil cooler assy.
1	Jagg 4700 offset oil filter adapter assembly
1	Regulator spacer bracket
3 ft	Jagg 30R7spec black oil hose
4	7/8" black worm-drive hose clamps
2	1/4" spacer
2	1/4-20 Allen head screw
2	1/4-20 nut with Nylok insert
1	Jagg anti-rotation device
2	Bolts: 10-24 x 1-3/8" cap head, black
1	Stock-to-Jagg oil filter nipple
1	Zip-tie

TOOLS NEEDED
Strap wrench or oil filter removal tool
Phillips head screwdriver
7/8" socket
1" deep-well socket
5/32" Allen wrench
7/16" Allen wrench (if removing a stock H-D oil cooler)
Hose cutter or sharp knife

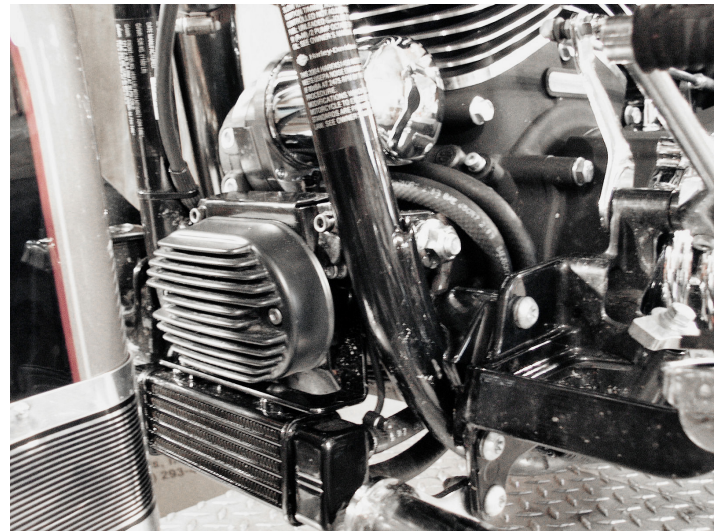
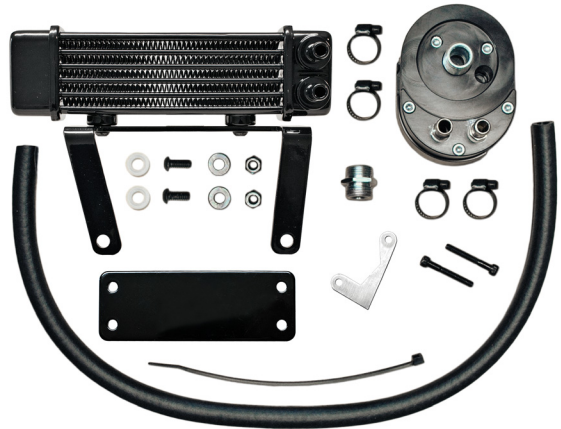

BASIC SYSTEM INSTALLATION GUIDELINES

- Route oil hose to avoid any hot surfaces or moving parts. Ensure all bends are smooth, with no sharp turns that may restrict oil supply to the engine.
- Oil cooler is designed to mount as detailed in these instructions. Any modifications may lead to decreased performance or item failure.
- When cutting oil hoses, always use a sharp knife, single-edge razor blade, or hose cutter. Make a straight, clean cut at 90° to the oil hose. This will ensure a proper fit where the oil hose attaches to its connection.
- Over tightening hose clamps may cause oil leaks.

CAUTION: ALLOW MOTORCYCLE TO COOL BEFORE ATTEMPTING INSTALLATION OR RISK SERIOUS INJURY.

Part 1: Install Jagg offset oil filter adapter

The Jagg offset oil filter adapter is used to access the oil supply for the installation of a Jagg oil cooler. The adapter features a built-in automatic thermostat to allow oil to by-pass the oil cooler, simply being filtered and returned to the engine, until the bike warms up to operating temperature. Once the bike reaches operating temperature, the thermostat will close the adapter's by-pass hole, sending hot, filtered oil to the oil cooler, and delivering cool, clean oil to the engine.

Oil flow direction from adapter: oil feeds the oil cooler from the fitting on the left side and returns to the fitting on the right side, as viewed from front with oil filter adapter fittings at bottom.

1. Remove spin-on oil filter, and clean the filter mounting surface thoroughly.
2. If removing and upgrading a factory Harley-Davidson oil cooling system, uninstall the stock oil filter adapter by removing the flanged oil filter nipple that holds the adapter in place using a 7/16" Allen wrench. Locate the stock-to-Jagg oil filter nipple (shown at right) included in the kit. Install by inserting the orange-painted end into the port where the stock oil filter stem was removed. Using a 7/8" socket, tighten until the hex is flush against the oil filter housing.
3. Disassemble the Jagg offset oil filter adapter by removing the five Allen head bolts from the front face of the adapter using a 5/32" Allen wrench. Then remove the front half of the adapter (the portion with hose fittings attached).
4. With the longer/offset end of the adapter at the top, place the back half of the adapter (the portion with the flat rubber o-ring) over the threaded oil filter stem and tighten the included 1" lock-nut to finger-tight. The adapter's flat sealing rubber o-ring should face in, toward the stock oil filter housing, and be free of de-



Stock-to-Jagg
oil filter nipple

- bris. (Do not apply oil to this o-ring.)
5. Locate part 4600AR-C Jagg anti-rotation device. Installation of this device will ensure the Jagg 4700 offset oil filter adapter will not rotate during future oil filter removal.
 6. Place the anti-rotation device against the face of the front half of the adapter in the orientation shown below.
 7. Insert the two black 10-24 Allen head bolts included with the anti-rotation device through the appropriate holes on the oil filter adapter as shown at right.
 8. Place the front half of the adapter over the already-installed back half and rotate the entire adapter to the left until the anti-rotation device makes contact with the engine case.
 9. Remove the front half of the adapter and hold the back half of the adapter in its current orientation. Using a 1" deep-well socket securely tighten the 1" lock-nut so the back half of the adapter will not rotate and the sealing o-ring is tight against the stock filter mount. This may require a prying force applied against the adapter to allow tightening while retaining the chosen orientation.
 10. Install AFM gasket onto the back half of the adapter.



4600AR-C Jagg
anti-rotation device

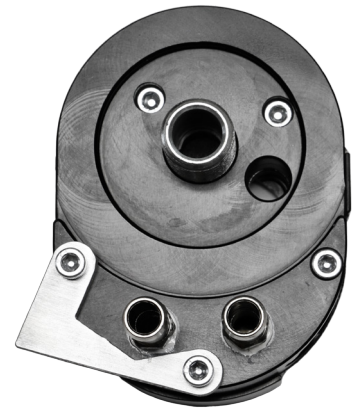

Anti-rotation device installed

CAUTION: AFM gasket should be applied dry. No additional gasket sealing compound is required. Ensure that the adapter halves are free of oil residue.

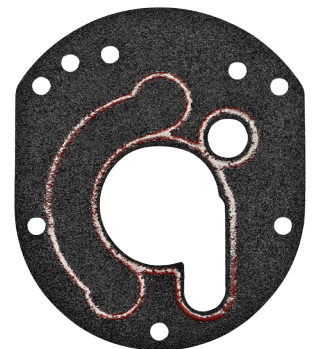

AFM gasket

11. Place the front half of the adapter against the gasket and install Allen bolts loosely. If a thread lock compound is optioned, please choose a medium strength and use it on the Allen bolts at this step.
12. Evenly draw the two halves of the adapter together by gradually tightening the Allen bolts in an alternating criss-cross pattern (e.g., like tightening wheel lug nuts on a car).
13. When the adapter halves have been evenly drawn together, firmly tighten the Allen bolts in the same alternating criss-cross pattern as the previous step.

SERVICE NOTE: Inspect adapter and screws for tightness at each oil filter change.

Part 2: Oil cooler mounting

14. Locate the voltage regulator on the motorcycle. Remove the voltage regulator Allen head mounting screws and retain for future use (see Installation photo 1).



Installation photo 1

15. Unclip the wire retainers from their posts on the regulator backing plate.
16. Insert the bottom of the regulator backing plate bracket through the oil cooler mounting bracket, taking care not to pinch the regulator wires (see Installation photo 2).
 - TIP:** Unfasten the regulator wiring from the retaining clip in the backing plate.

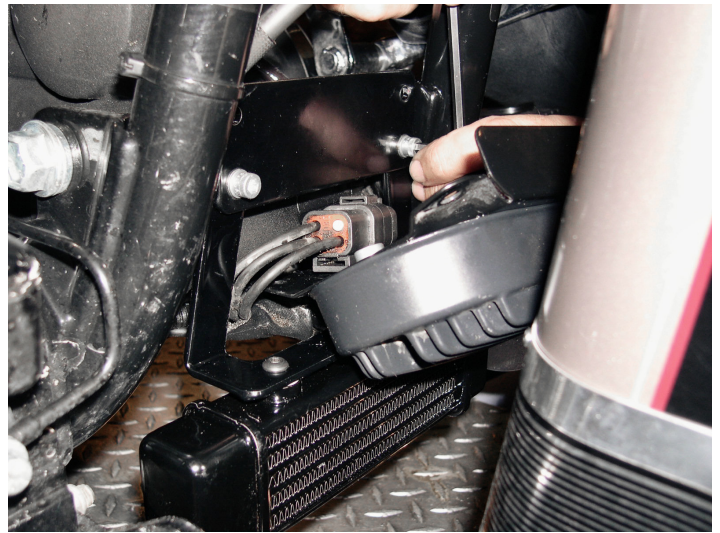

Installation photo 2

17. Locate the included regulator spacer bracket. Orient the lower holes in the regulator spacer bracket to line up with the holes in the oil cooler mounting bracket and remount both items to the original voltage regulator bracket mounting holes in the block. Fasten these items with the Allen head screws removed in step 14 (see Installation photo 2).
18. Reattach the voltage regulator to the top holes in the supplied regulator spacer bracket using the 1/4" spacers, 1/4-20 screws, and 1/4-20 Nylok nuts included in the kit.
19. Cable-tie the wires under the regulator together using the zip-tie included in the kit.

CAUTION: The regulator ground wire will have been detached during installation. Ensure reinstallation of the regulator ground wire.

Part 3: Oil cooler plumbing

20. Cut the provided oil hose into two lengths and install the oil hoses onto the hose fittings on the oil cooler. Secure hose over the fittings with the 7/8" black hose clamps included in the kit so the hose cannot pull over the barb on the fitting. The flow orientation of the oil cooler is non-directional, so either hose fitting will allow proper flow as an inlet or an outlet.
 - TIP:** Install 7/8" black hose clamps loosely onto hoses before installing hoses onto oil cooler nipples. A touch of oil on oil cooler

nipples allows the hoses to push on easily.
 21. Measure, cut, route, and attach the oil hoses to the oil filter adapter. Secure hose over the fittings using the 7/8" black hose clamps onto the oil filter adapter inlet and outlet as detailed in the previous step.

NOTE: It may be necessary to rotate hose clamps to ensure hose clamps do not interfere with oil filter installation.

CAUTION: Take care to make gentle bends in oil hose routing from oil cooler to adapter. Sharp bends may collapse under heat load and cause restriction to oil flow.

22. Install oil filter onto the threaded stem of the oil filter adapter. Tighten per factory/service manual recommendations.

Part 3: Final inspection

23. Inspect the oil hoses to ensure there are no tight bends that may restrict oil flow and that they are not contacting any moving parts. If necessary secure the new hoses to the frame with plastic zip-ties.

24. Refill the engine with the correct amount and type of oil. Check the oil level per factory/service manual recommendations.

25. Start the engine and let it idle. Check all oil hose connections for any leakage. Tighten any hose clamps that may be leaking.

NOTE: Over-tightened hose clamps may cut into oil lines and cause oil leaks.

26. After installation completion and engine warm-up, shut the engine down and recheck the oil level. Correct the oil level if necessary, but do not over-fill.

SERVICE & UPGRADE ITEMS AVAILABLE	
PART NO.	DESCRIPTION
GK4600	Gasket service kit for Jagg offset oil filter adapter. Includes: AFM gasket and large o-ring for Jagg 4700 offset oil filter adapter
21-SSN06-B	Stainless steel braided oil hose. High performance 3/8"(-06) Nitrile rubber oil hose with stainless steel braided jacket
08-0069	Oil filter strap wrench. Simply one of the easiest oil filter wrenches to use. Engineered to access oil filter for removal around almost any obstacle. Use with 3/8-inch drive ratchet extension. Takes virtually no space in the toolbox or the saddlebag.
22-HF06-SI (silver) 22-HF06-BK (black)	Jagg hose finishers with integrated worm-drive hose clamps dress up the terminal ends of your oil hose to resemble high-performance racecar compression fittings without the installation hassle. 7/8" integrated hose clamps, suitable for 3/8" (-06) plain or braided oil hose. Available in black or silver anodized finish.
22-HS06-SI (silver) 22-HS06-BK (black)	Jagg hose separators keep your oil lines separated, provide extra structure, and look trick! Pair with hose finishers for a complete, finished look. Machined from billet aluminum and anodized either bright silver or black, these items install in a snap.