

**Performance Series 2-Channel  
Amplifier Kit For Connection To The  
Jensen HD1BT Radio As Installed Into  
1998-2013 Harley® Davidson Ultra/  
Street/Electra Glide Fairings**

**#JMAA-2000HC-JHD1**

**Installation  
and Operation  
Instructions**

## Product Description

This exciting new J&M Performance Series fairing speaker amplifier kit has been designed specifically for use in the 1998-2013 Harley® Ultra/Street/Electra Glide fairing, with the Jensen #HD1BT radio installed.

This is a full range class D amplifier and is spec'd at 100watts RMS per channel, both channels driven, continuous into a 2 ohm load @ 14.4vdc.

Amplifier mounts to the top of the custom made stainless steel bracket system.

Custom made plug-n-play wiring harnesses/RCA-RCA adapters are included with this amplifier kit, top quality heavy gauge power/ground wires are used for the fused battery connection, along with all necessary mounting hardware & complete installation/ operation instructions.

Amplifier itself measures 6 ½" X 4 ¾" X 1 ¾".

## Installation Instructions

1. Remove the outer fairing shell, seat, and fuel tank.
2. By following along the factory wiring harness, route the amplifier power harness from the fairing, under the fuel tank, and on to the battery. (removal of the fuel tank is necessary for proper installation)
3. After first disconnecting the negative battery cable from the battery, connect the positive (red) lead from the amplifier power harness directly to the positive post of the battery. Then connect the negative (black) lead from the power harness to the same bolt/stud on the frame (forward of the battery) that the negative battery cable is connected to. Then reconnect the negative battery cable to the battery. **(Figure A)** Do not connect the negative (black) lead from the amplifier to the negative post of the battery.
4. Remove both the left and right forward radio mounting bolts. Loosen but do not remove both the left and right rearward mounting bolts. **(Figure B)**
5. Position the J&M Amp/Bracket assembly above the radio and slide into position. (Remove tie-straps and re-position the factory wiring harness as needed to allow the amplifier to fit into place properly) **(Figure C)**
6. Replace the forward radio mounting bolts and then tighten all (4) of the mounting bolts. **(Figure D)**
7. Make Amplifier/Speaker connections according to diagram. **(Figure E)**
8. Test the system for proper operation before reassembling the fairing, realizing that full sound quality and fidelity will not be heard until the outer fairing shell is completely reinstalled.

Fig. A

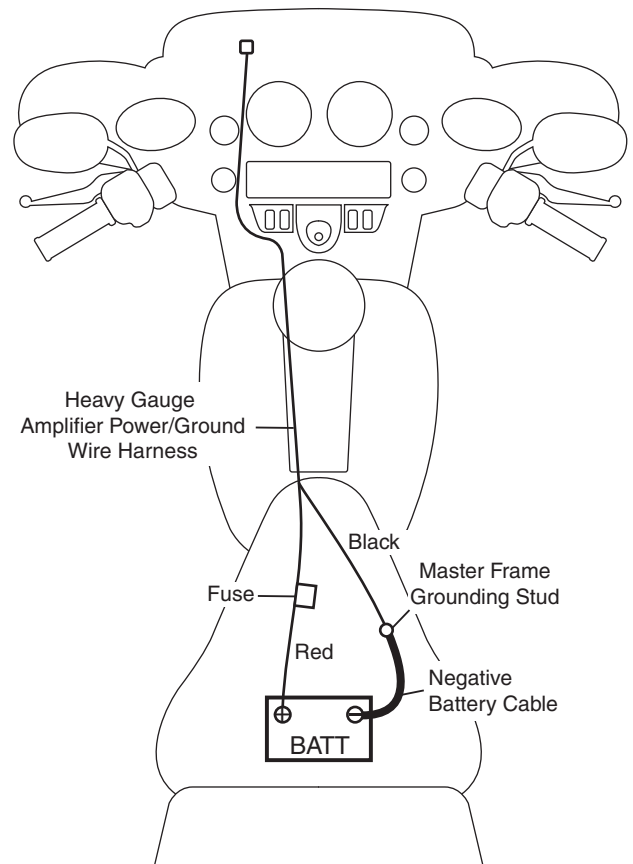

Fig. B

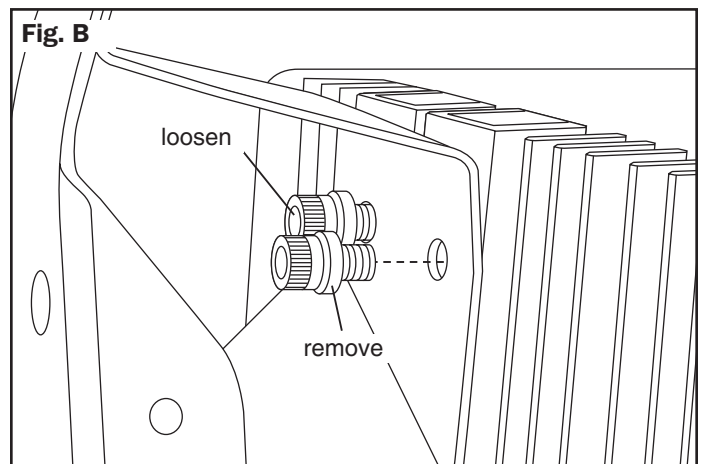

Fig. C

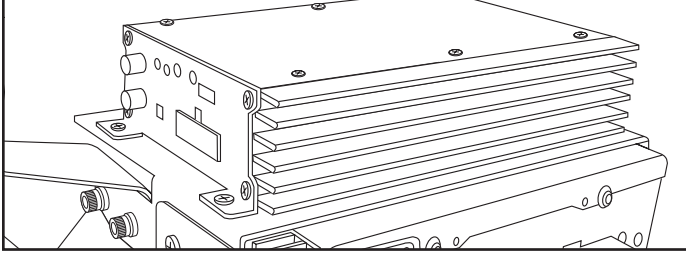

Fig. D

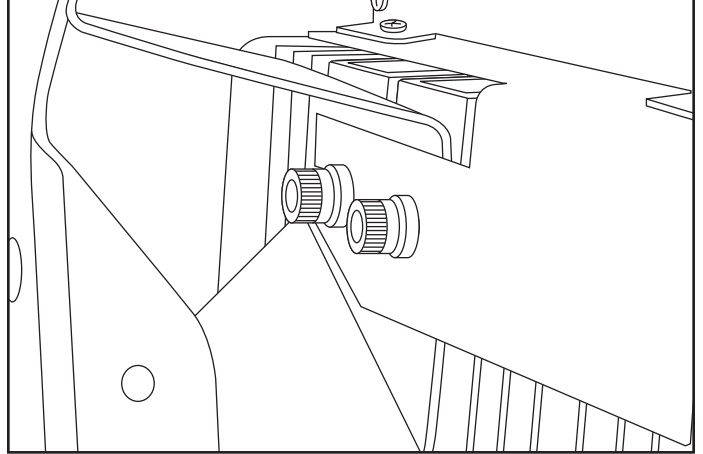
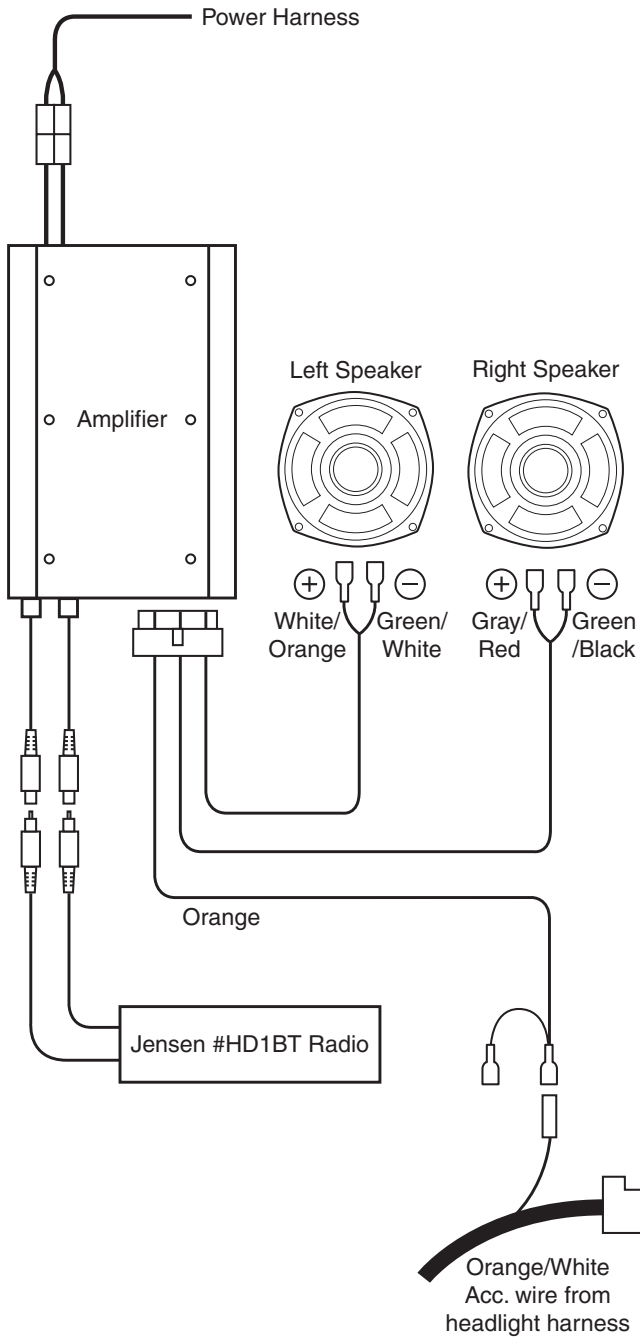

Fig. E



### Specifications

#### JMAA-2000

#### Full Range Class D Amplifier

Output Power (RMS)	
Stereo @ 2ohms	2 x 100 watts
Frequency Response -3dB	10Hz - 22kHz
Channel Separation	>50dB
Input Sensitivity	0.2 - 10v

Thank you for the confidence you have shown in J&M Corporation by purchasing one of our innovative products.

