

**350W ROKKER® XXR
Amplifier Kit For 2015-19
Harley® RoadGlide/
Ultra/Ultra LTD. Fairing**

#JAMP-350HR15

**Installation
and Operation
Instructions**

Product Description

2-ch 350w fairing speaker amplifier kit for 2014-2019 Harley® StreetGlide or Ultra with stock Harley 4.3 Std, 6.5GT or new GTS touch-screen radio, NO SPECIAL FLASH needed.

Full range class D audio amplifier, spec'd at 175watts RMS per channel X2, (350w total) into 2-ohm load @ 14.4vdc.

Amplifier mounts to custom made stainless steel 2-piece bracket system, to provide solid and secure mounting inside the StreetGlide or Ultra fairing.

ROKKER XXR amplifiers are dialed in for this specific StreetGlide/Ultra speaker configuration, to provide maximum highway performance. (Updated amplifier gain/frequency settings as of 09-15/2018)

Custom made plug-n-play wiring harnesses are included, along with heavy gauge power/ground wires for the fused battery connection, all necessary mounting hardware & complete installation/operation instructions.

Amplifier itself measures 7 ¼" X 4 ¾" X 1 ¾".

Installation Instructions

1. Remove the outer fairing shell, seat, and fuel tank.
2. By following along the factory wiring harness, route the amplifier power harness from the fairing, under the fuel tank, and on to the battery. (Removal of the fuel tank is necessary for proper installation)
3. After first disconnecting the negative battery cable from the battery, connect the positive (red) lead from the amplifier power harness directly to the positive post of the battery.

Connect the negative (black) lead from the power harness to the same bolt/stud on the frame that the negative battery cable is connected to.

Then reconnect the negative battery cable to the battery. **(Figure A)**
Do not connect the negative (black) lead from the amplifier to the negative post of the battery.

4. Disconnect all plugs from the rear of the radio and then remove the radio itself by removing four mounting bolts. **(Figure B)**
5. Place the amplifier into the fairing upside down with the power/ground cable (Red and Black wires) facing towards rear of the bike.
6. Connect the amplifier main wiring harness to the amp before securing to the mounting bracket. Center the amp into position, place top bracket with J&M Logo facing up, align the screw holes and insert the four supplied screws and tighten securely. **(Figure C)**
7. Connect the main power cable and tuck wire down on the side of the amplifier so as not to interfere with the radio as it is reinstalled. Connect the RCA input harness to the amplifier.
8. Make Amplifier/Speaker connections as per diagram. **(Figure D)**
9. Re-install the factory radio.
10. Test the system for proper operation before reassembling the fairing, realizing that full sound quality and fidelity will not be heard until the outer fairing shell is completely reinstalled.

Fig. A

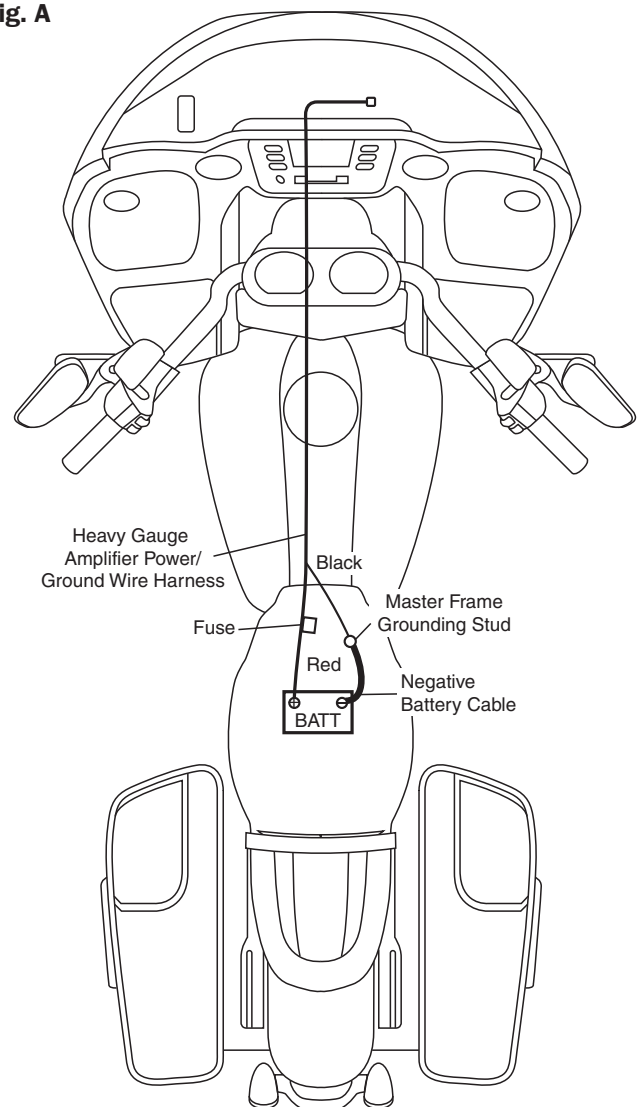

Fig. B

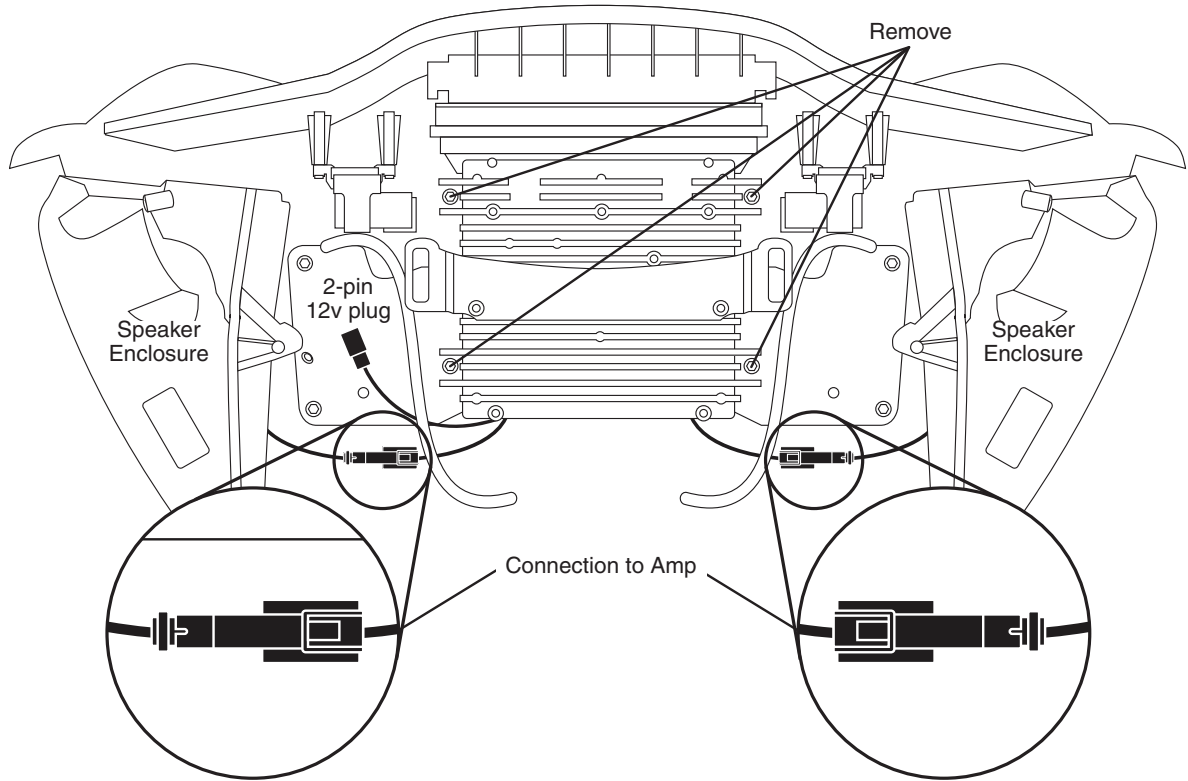

Fig. C

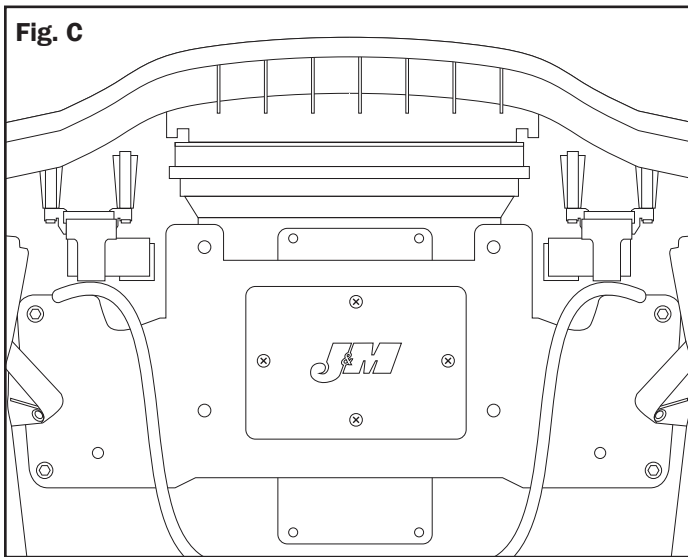
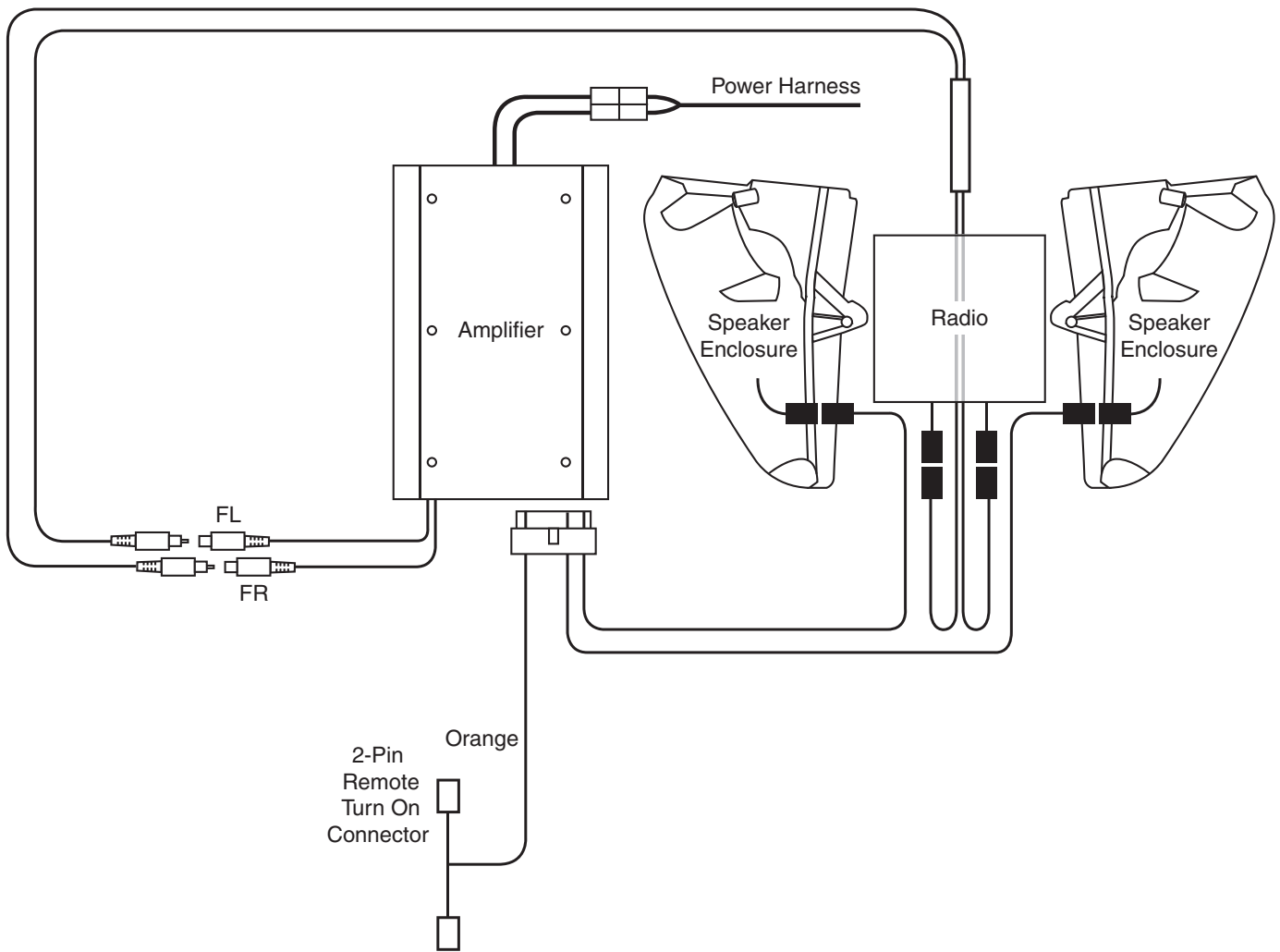

Fig. D



Specifications

ROKKER® XXR 350w RMS

Full Range Class D Amplifier

Output Power (RMS) @ 1% THD 1000Hz 14.4V
Stereo @ 2ohms 2 x 175 watts RMS Continuous
Frequency Response -3dB 20Hz - 31kHz Capable

S/N Ratio
Separation >88dB
Input Sensitivity .35V - 3.9V
Input Impedance 20K

Thank you for the confidence you have shown in J&M Corporation by purchasing one of our innovative products.

