



**ROKKER® XXR 350W 2-CH
Amplifier Kit For 2006-2013
Harley® RoadGlide Fairing**

#JAMP-350HR06

**Installation
and Operation
Instructions**

Product Description

This exciting new J&M ROKKER XXR 2-channel 350w fairing speaker amplifier kit has been designed specifically for use on the 2006-2013 Harley® RoadGlide with the Harley HK radio.

This is a full range class D audio amplifier and is spec'd at 175watts RMS per channel X2 channels, (350w total) driven continuous into a 2 ohm load @ 14.4vdc.

The ROKKER XXR amplifier's settings have been dialed in & optimized for this exact speaker configuration, to provide maximum highway performance from your Harley bagger audio system.

Amplifier mounts to the custom made stainless steel bracket system, to provide solid and secure mounting inside the RoadGlide fairing.

Custom made plug-n-play wiring harnesses are included with this amplifier kit, top quality heavy gauge power/ground wires are used for the fused battery connection, along with all necessary mounting hardware & complete installation/operation instructions.

Amplifier itself measures 7 1/4" X 4 3/4" X 1 3/4".

IMPORTANT NOTE: Some 1998 thru 2005 model Road-Glides require the replacement of the factory grill assembly/speaker adapter plates in order for the J&M 350w amp kit and/or 7.25 speaker kit to be installed. It will be necessary to remove the outer fairing and inspect the factory installed grill/ adapter assemblies to determine if they need to be replaced. The early style assemblies can be identified by the method of attachment to the inner fairing. If the screws attaching the speaker go completely through the grill/adapter and into the inner fairing mounting bosses you have the early style assemblies and they will need to be replaced with the later style factory grill/adapter assemblies and mounting hardware listed below. The later style grill/adapter utilizes independent hardware to attach it to the inner fairing then the speaker is attached to the grill/adapter with 4 additional screws. If you have the later style assemblies, the J&M 350w amp kit and/or 7.25 speaker kit will fit with no additional parts or hardware needed.

UPGRADE PARTS AND HARDWARE TO BE PURCHASED FROM J&M Corporation IF NEEDED

#RRPA-RGSPA LH & RH SPEAKER ADAPTER PLATE KIT

Installation Instructions

1. Remove the outer fairing shell, seat, and fuel tank.
 2. By following along the factory wiring harness, route the amplifier power harness from the fairing, under the fuel tank, and on to the battery. (removal of the fuel tank is necessary for proper installation)
 3. After first disconnecting the negative battery cable from the battery, connect the positive (red) lead from the amplifier power harness directly to the positive post of the battery. Then connect the negative (black) lead from the power harness to the same bolt/stud on the frame that the negative battery cable is connected to. Then reconnect the negative battery cable to the battery. **(Figure A)** Do not connect the negative (black) lead from the amplifier to the negative post of the battery.
 4. Remove both of the flange nuts from the right-side inner-fairing mounting studs. **(Figure B)**
- NOTE:** When installing the amplifier in conjunction with J&M's 7.25 speakers, it is necessary to install the speakers before installing the amplifier. This not only allows for easier speaker installation, but is required for proper positioning and adjustment of the amplifier/bracket assembly before securing the assembly to the inner fairing.
5. After first connecting the power harness to the amplifier, install the amplifier assembly into the inner fairing by placing the assembly between the inner fairing and the right-side storage pocket while positioning the slotted holes in the mounting bracket over the right-side inner-fairing mounting studs. Re-install the flange nuts loosely but do not tighten them at this time. **(Figure C)**

Fig. A

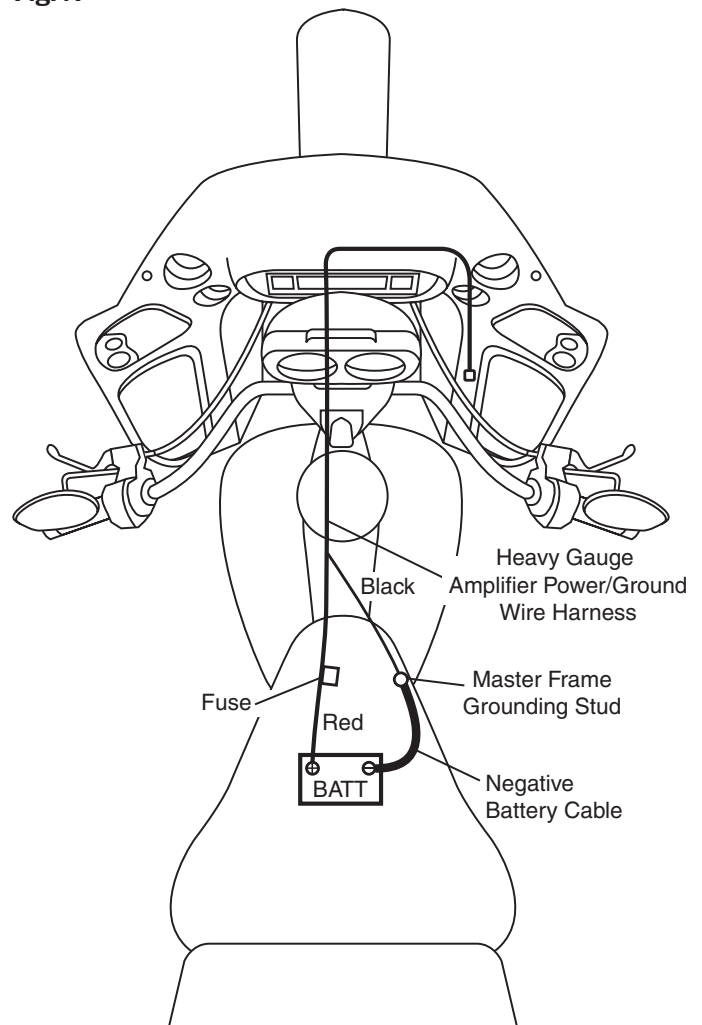

IMPORTANT NOTE: ROUTE BOTH THE AMPLIFIER POWER HARNESS AND THE FACTORY TURN SIGNAL WIRING HARNESS ABOVE THE AMPLIFIER BEING SURE NOT TO ALLOW THEM TO BECOME PINCHED BETWEEN THE AMPLIFIER AND THE FAIRING DURING INSTALLATION.

6. Position the amplifier/bracket assembly so that there is 1/8" of clearance or greater between the amplifier and the lower edge of the 7.25 speaker, then tighten the flange nuts securing the assembly to the inner fairing. **(Figure D)**
7. Make amplifier/speaker connections according to diagram. **(Figure E)**
8. Test the system for proper operation before reassembling the fairing, realizing that full sound quality and fidelity will not be heard until the outer fairing shell is completely reinstalled.

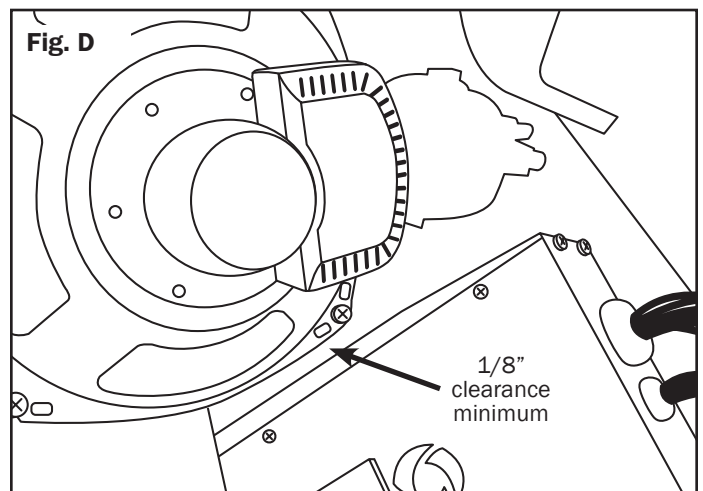
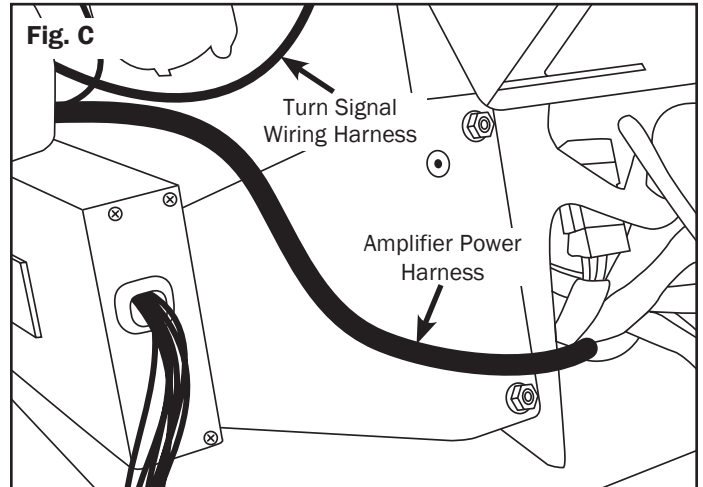
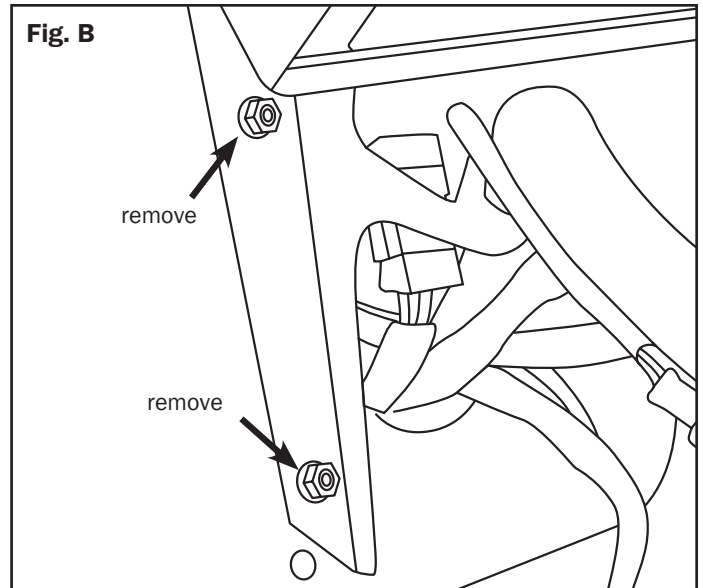
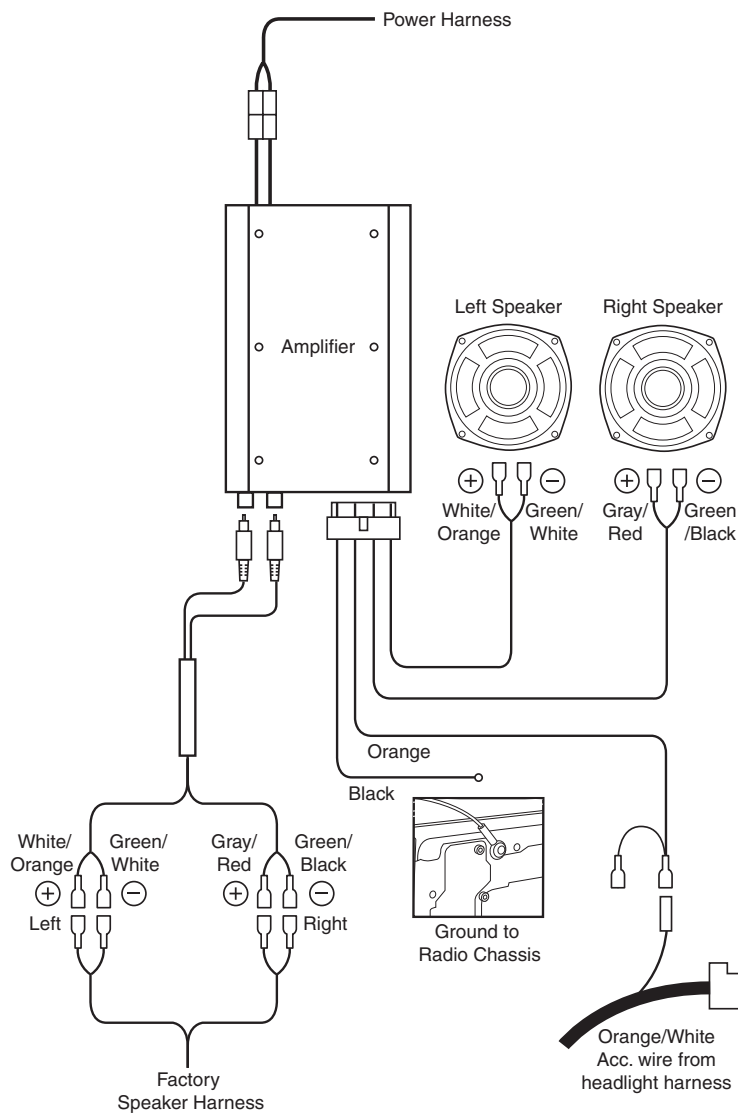

Fig. E



Specifications

ROKKER® XXR 350w RMS

Full Range Class D Amplifier

Output Power (RMS) @ 1% THD 1000Hz 14.4V
 Stereo @ 2ohms 2 x 175 watts RMS Continuous
 Frequency Response -3dB 20Hz - 31kHz Capable

S/N Ratio
 Separation >88dB
 Input Sensitivity .35V - 3.9V
 Input Impedance 20K

Important Programming Note: The amplifier gain & frequency response adjustments have been pre-set at our factory for this specific Harley Davidson audio system application, using speakers with an impedance of 2-ohms, to provide maximum performance at highway speeds. Should speaker impedance load change, alternate adjustments can be made by removing the small sticker that is placed over the amplifier's input gain control screw.



Thank you for the confidence you have shown in J&M Corporation by purchasing one of our innovative products.