

**Flexpower® Passive In-Fairing
AM-FM-WB Antenna for
2014-18 Harley Davidson®
Ultra or Streetglide**

#FPA-HCFM14-P

**Installation
and
Instructions**

Product Description

J&M's new Passive FLEXPOWER® hide-a-way AM/FM/WB antenna is THE BEST hide-a-way antenna on the market today, for ALL THREE reception bands of AM, FM and WB, to help you eliminate altogether the rear mounted antenna on your 2014-2018 Harley Ultra or StreetGlide.

This new passive version (no 12v connection required) provides all of the great reception performance of our original design, but with the correct "FAKRA" style plug on the end of the cable, for direct connection to the 2014 Harley radio (either version).

Over the years we have learned that proper tuning and adequate stinger capture area is far more important to reception quality for an in-fairing (hidden) antenna, then trying to artificially amplify a less than ideal signal.

This unique in-fairing antenna is manufactured complete at our shop in Tucson Arizona USA using only high-grade copper coaxial cable & stinger wire, for maximum durability and performance.

Installation Instructions

1. Remove the windshield and outer fairing shell.
2. Unplug your stock antenna cable from the radio and plug the J&M antenna connector into the radio in its place. **(Figure A)**
3. Route the antenna lead-wire upward along the left side of the inner fairing, across the top and into the upper right hand corner of the inner fairing. **(Figure B)**

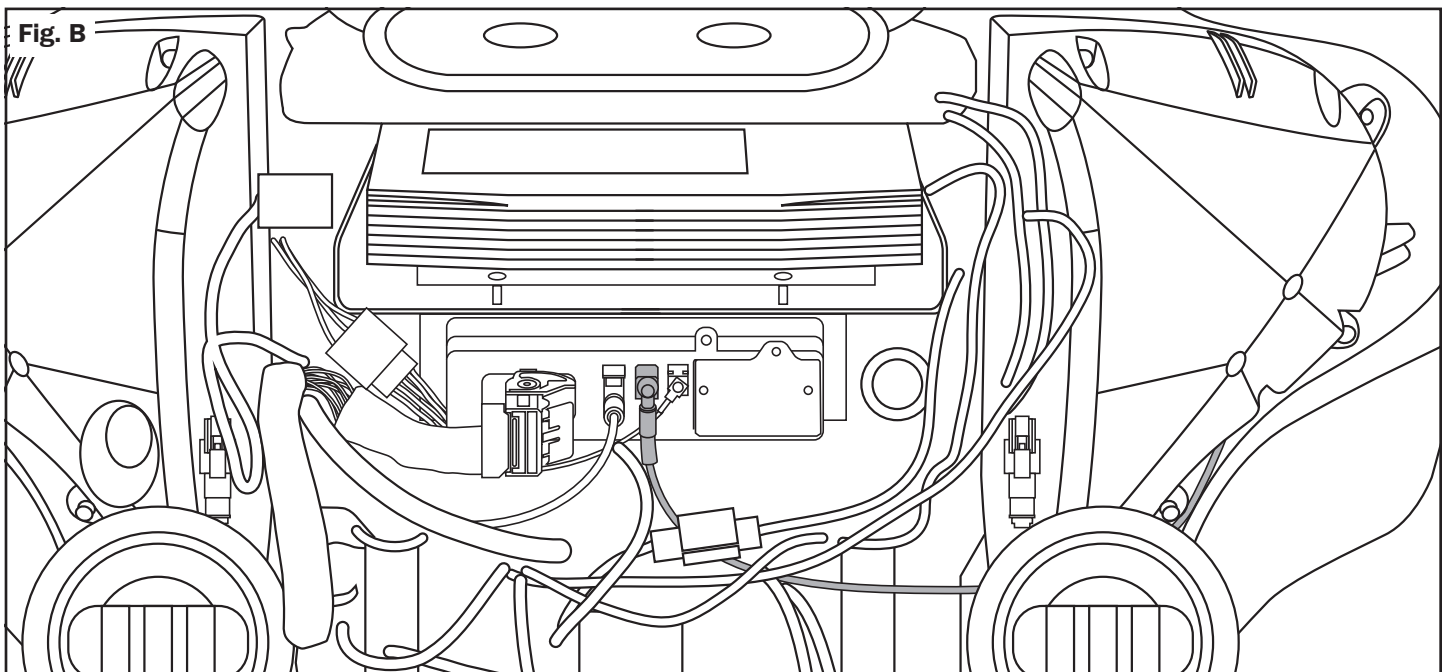
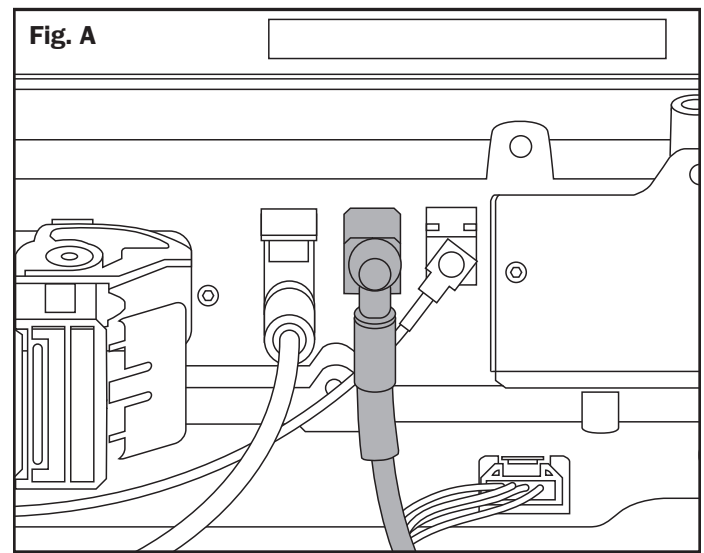

Thank you for the confidence you have shown by purchasing one of J&M's innovative products.

