

## **Mounting Instructions** **Driving lamps**



**Rallye 3000, 3000 Celis, 3003**



**Kit includes**

**Rallye 3000**

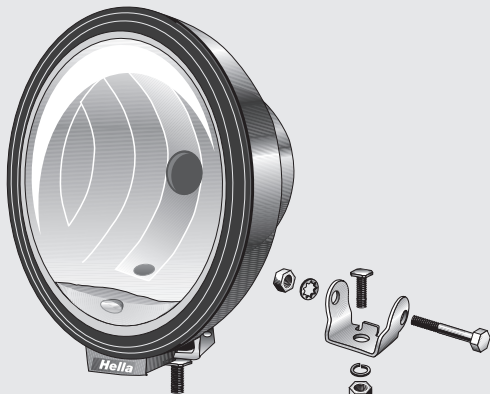

**Rallye 3000  
Celis**



**Volumen del suministro**

**Rallye 3003**

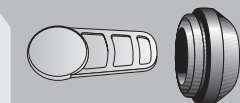
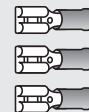
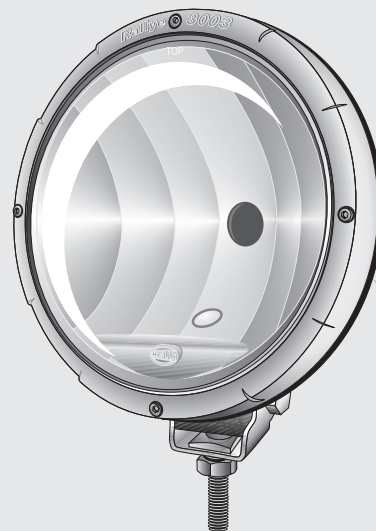

## Tools required

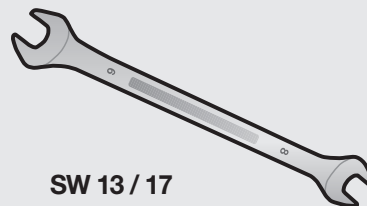
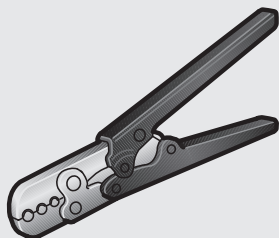
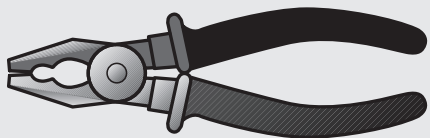

SW 13 / 17



3 mm

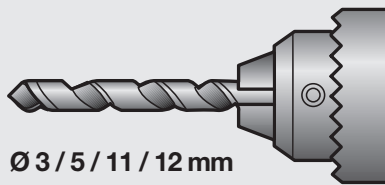
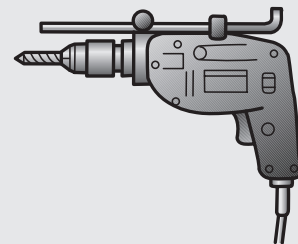

Ø 3 / 5 / 11 / 12 mm

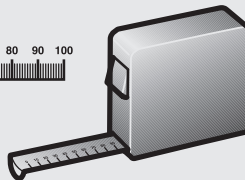

## Mounting

### Rallye 3000

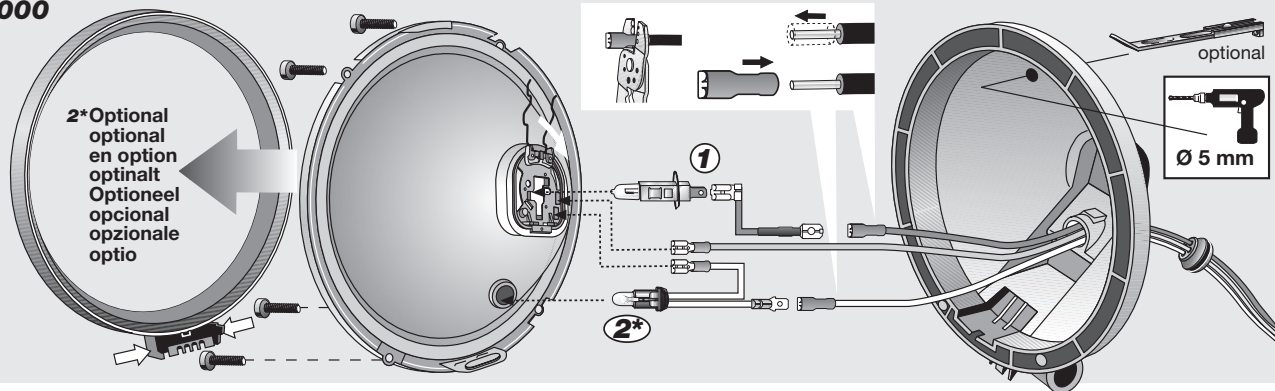

### Rallye 3000 Celis

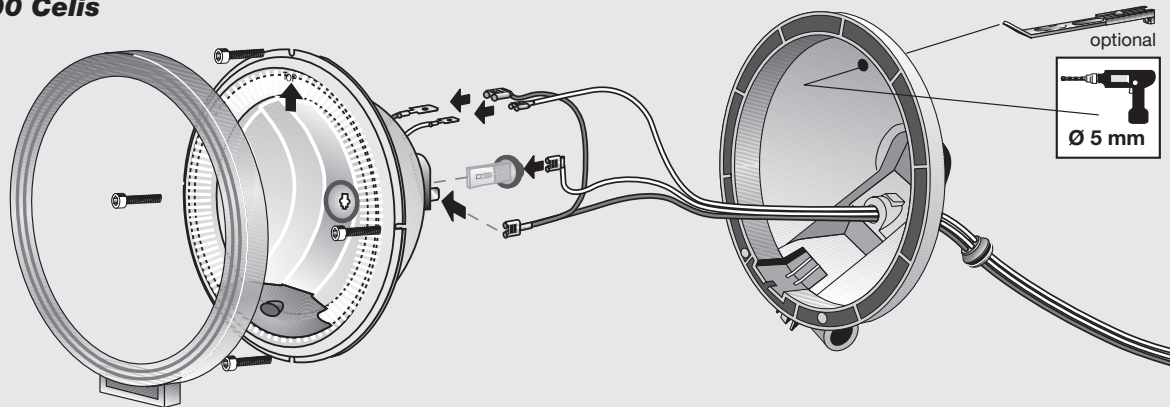

## Electrical connection

### Rallye 3000

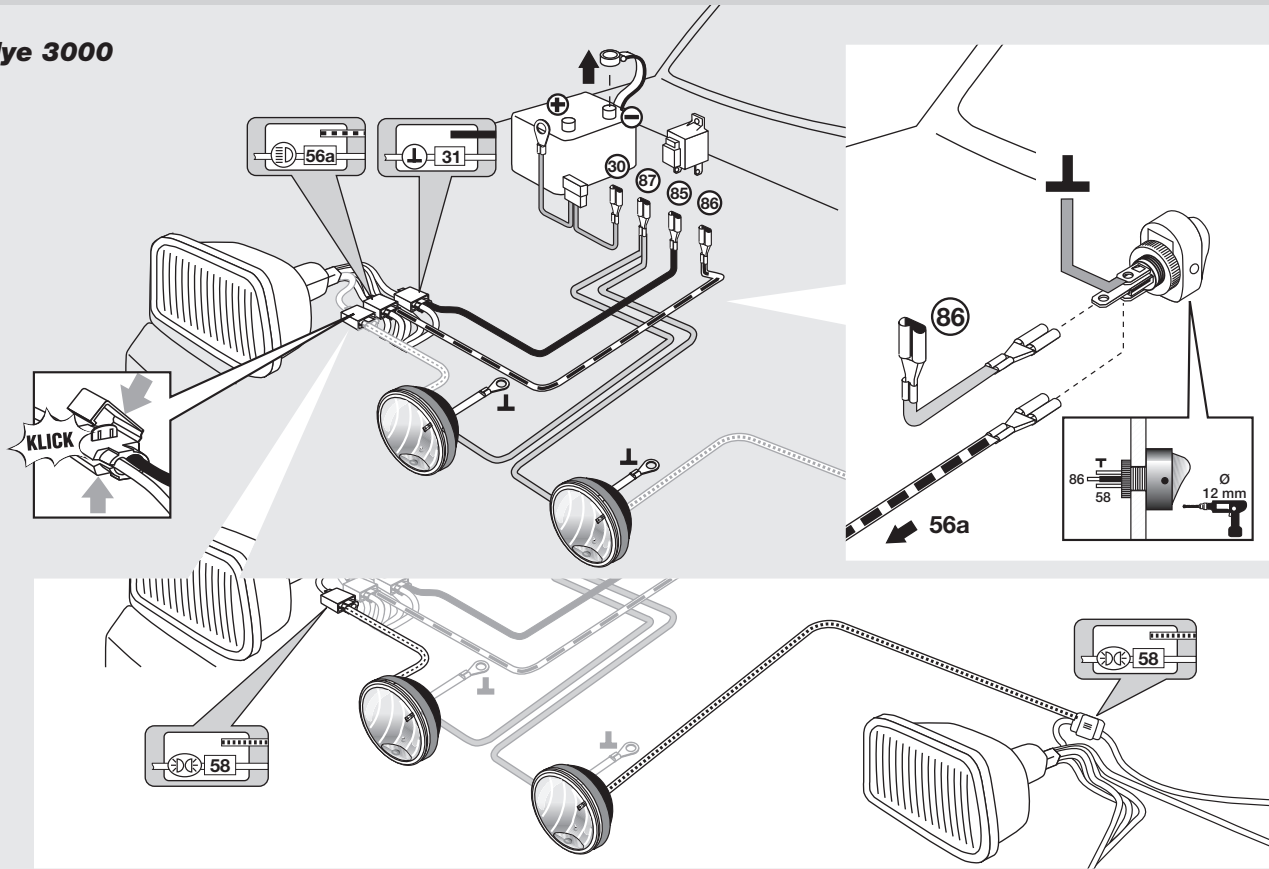

**Mounting**  
**Rallye 3003**

**A**

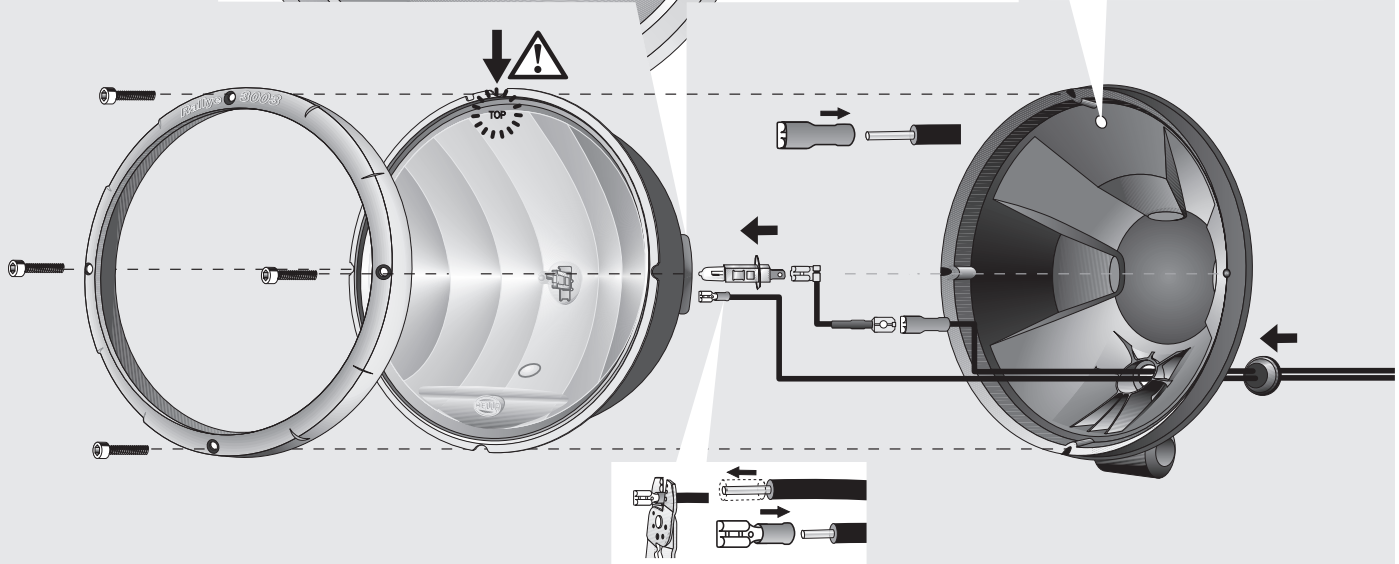
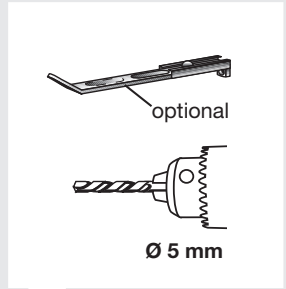
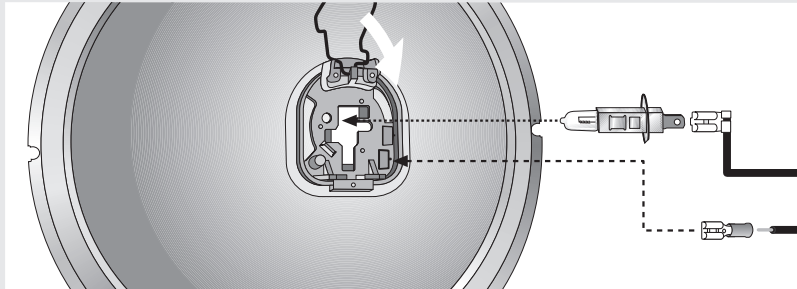

**Mounting**  
**Rallye 3003**

**B**

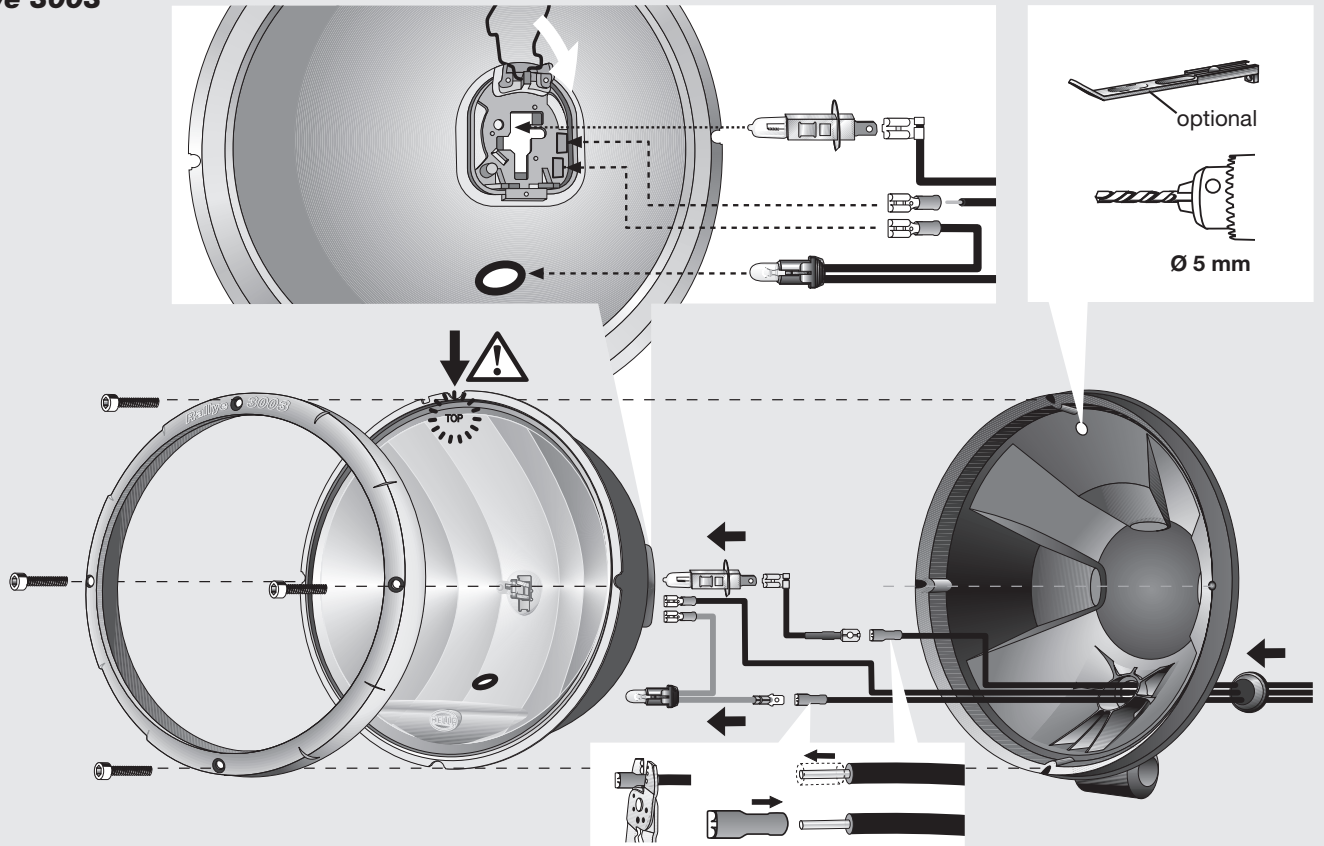

## Electrical connection

### Rallye 3003

I

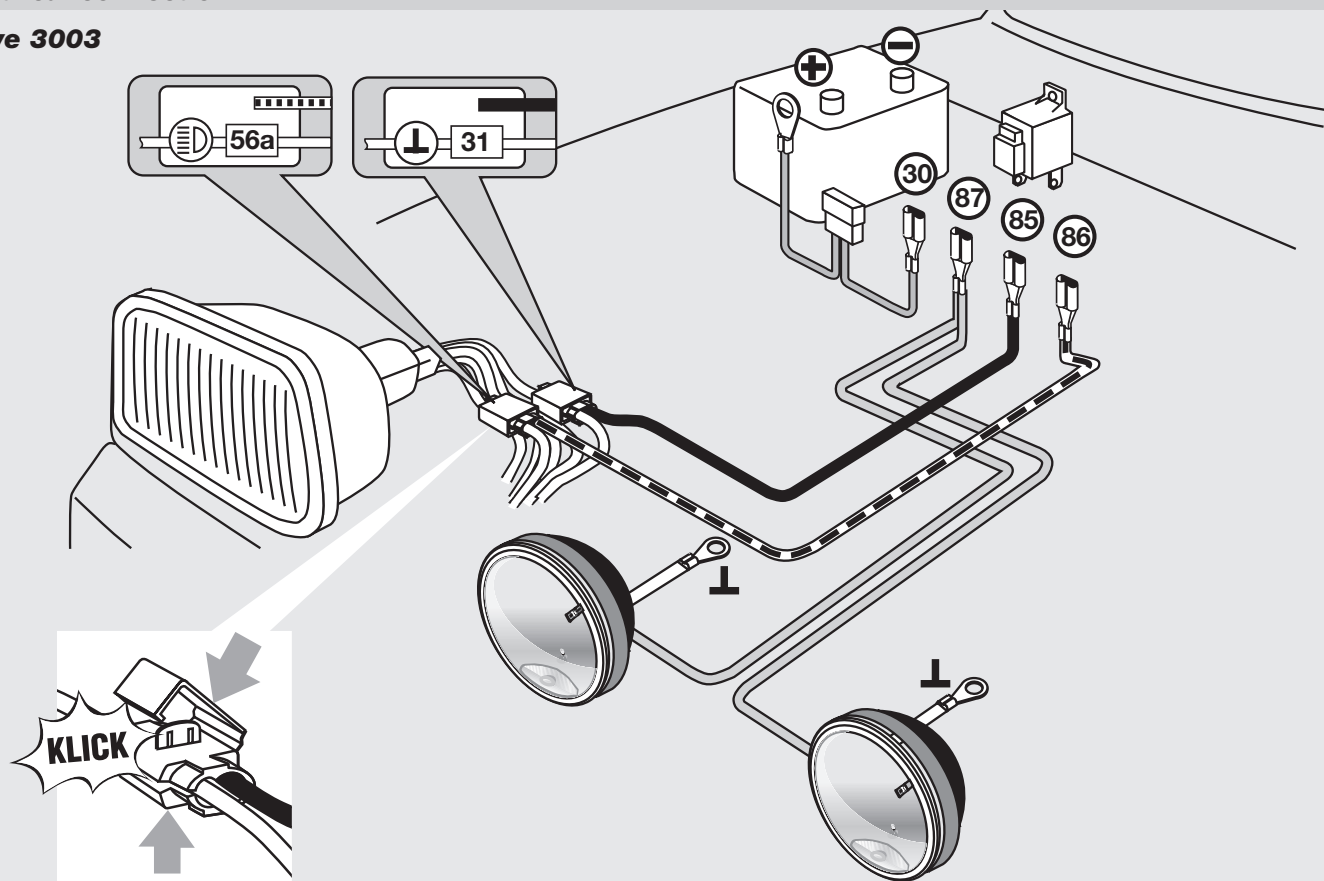



## Electrical connection

### Rallye 3003

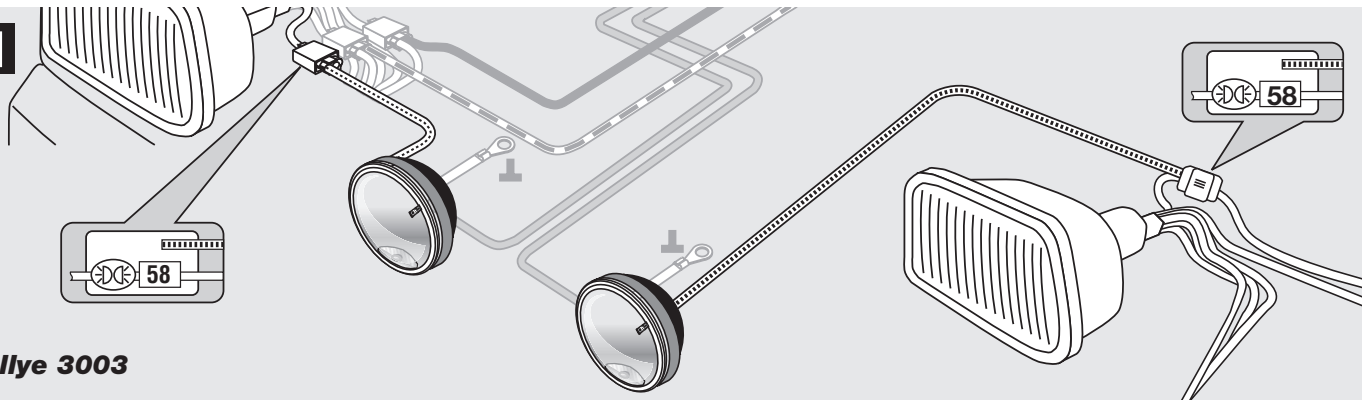
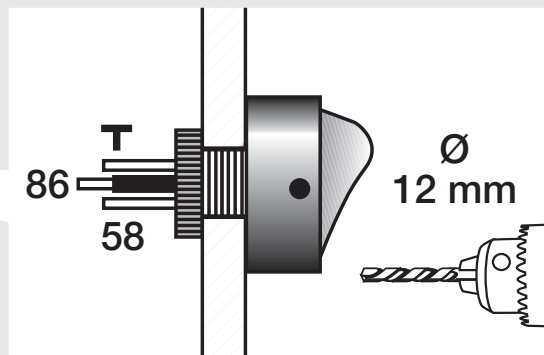
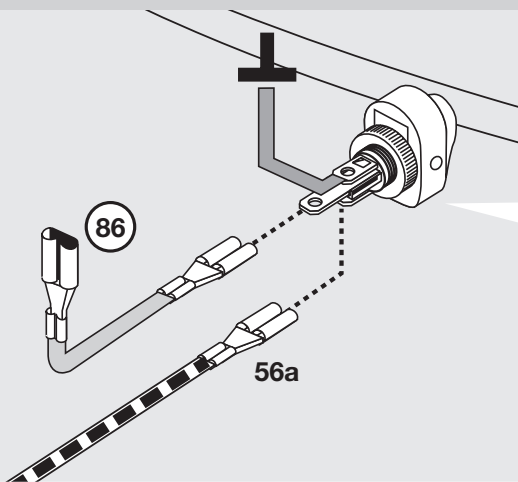

### Rallye 3003

## Accessories

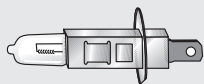

12 V-55 W:  
8GH 002 089-131

24 V-70 W:  
8GH 002 089-251

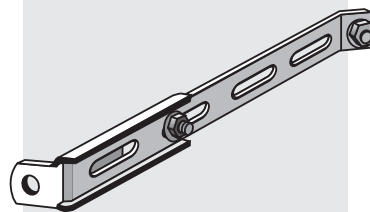
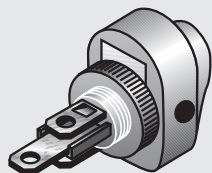

8HG 116 741-801

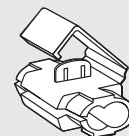

8KV 705 123-813



12 V:  
8GP 003 594-121

24 V:  
8GP 003 594-251

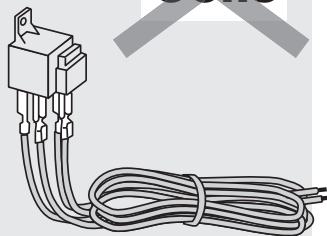

~~Celis~~

12 V:  
8KA 002 309-811

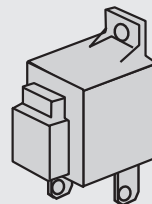

12 V:  
4RA 003 510-641

24 V:  
4RA 003 510-651



~~ECE~~

Rallye 3000:  
8XS 142 700-001

Rallye 3003:  
8XS 168 664-001

## ENGLISH

### Important:

Before starting fitting work, make sure there will still be sufficient air flow to the radiator grille (engine cooling). Attach both headlamps above the bumper.

## Fitting measurements: Rallye 3000, 3000 Celis

In Germany, all the additional fitting measurements shown in the sketches below must be observed when fitting auxiliary driving lamps with an integrated position light. If these mandatory fitting requirements are not

observed or the use of an additional pair of position lights is not permitted (e.g. in CH, A), the position light must not be operated. In this case, the cables to the position lights have to be disconnected. There are no special regulations for

the attachment of auxiliary driving lamps. The maximum attachment height of 4 m must not be exceeded. The legal regulations in individual countries must be taken into account.

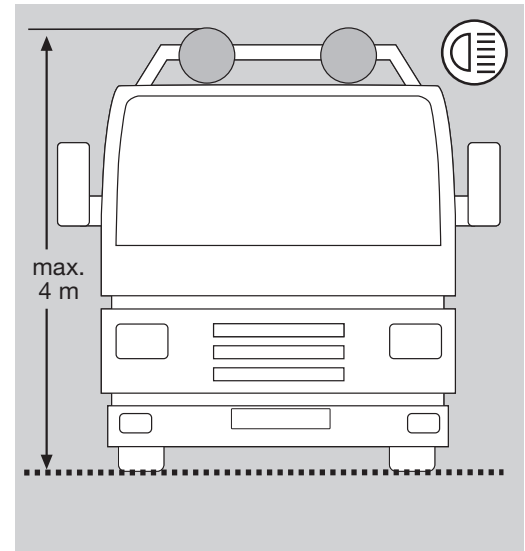
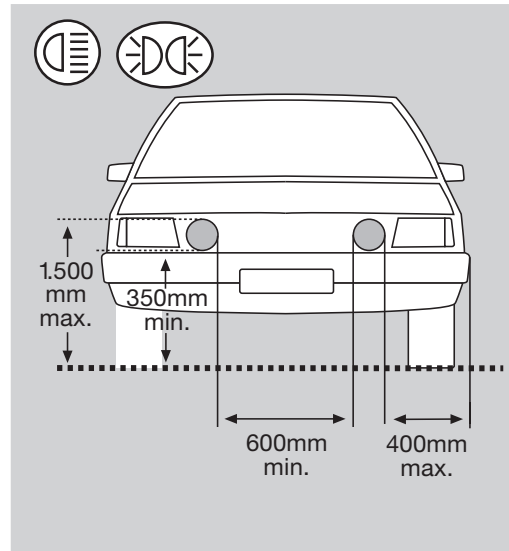

## ENGLISH

Headlamps must not vibrate or jut above the bonnet and must be attached symmetrically.

Choose a straight surface for the fitting position and mark the attachment points.

## Fitting: Rallye 3000, 3000 Celis: Page 4

Pre-drill with the 3 mm bit and then drill through using the 11 mm bit. Seal the drilled metal parts with corrosion protection agent.

Pre-fit the bracket. Open the housing and insert the bulb.

Do not touch the bulb with

your bare fingers! Use a tissue or similar. Put the housing together. Screw the bracket and housing together and route the cables carefully.

Screw the headlamps to the vehicle (using a two-point bracket if necessary).

## ENGLISH

Install the relay with the connection terminals facing downwards and protected against splashing. If required and permitted by legal regulations, install a switch on the dashboard. Route and connect the cables according to the circuit diagram. When wired according to circuit diagram **I** the auxiliary

## Electrical connection: Rallye 3000, 3000 Celis: Page 5

lamps are switched on together with the existing driving lamps. According to circuit diagram **III** the auxiliary lamps are switched on addition to the existing headlamps via a separate switch. According to circuit diagram **III** the CELIS® position lamps are connected and switched on together with the

parking light. Test the lighting system. Fasten the supply cables securely in place.

**Have the driving lamps adjusted at a workshop or service station. Only properly adjusted lamps provide optimum illumination.**  
**The use of the enclosed**

**protective caps (enclosed where applicable) is not permissible in areas governed by German Traffic Laws. However, it is permissible to use protective grilles.**

## ENGLISH

## Fitting: Rallye 3003: Page 6/7

Headlamps must not vibrate or jut above the bonnet and must be attached symmetrically. Choose a straight surface for the fitting position and mark the

attachment points. Pilot-drill with the 3 mm bit and then drill through using the 11 mm bit. Seal the drilled metal parts with corrosion protection agent.

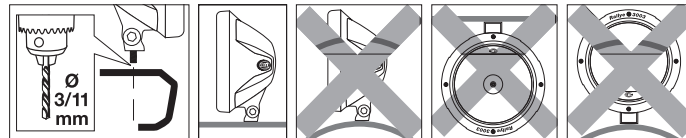

### Version A without position light.

If position light is definitely not required, remove the position light socket and rubber ring and press open the sealing lug provided.

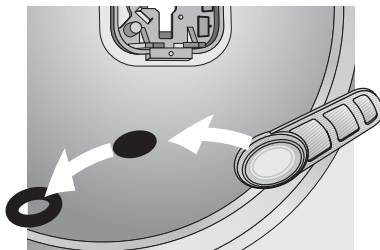

Insert the connection cable (2-wire) through the rubber seal and into the housing. Strip the cable and connect using two blade connectors. Fully insulated blade connectors for the H1 bulb.

Press the rubber seal in tightly to ensure watertightness. Insert the bulb and lock in place. Push the blade connectors on.

### Version B with position light.

In addition to version A, insert the connection cable (3-wire).

Connect the additional cable using fully insulated blade connectors. Pull the socket for the position light

out of the reflector, insert the bulb in the socket and press this back into the reflector again.

### Final assembly

Put the housing together. Screw the bracket and housing together and route the cables carefully. Screw the headlamps to the

vehicle (using a two-point bracket if necessary). Align the headlamps and tighten all screws. To guarantee an optimum beam pattern, make sure that the **“TOP”** marking

on the headlamp insert is always facing the top.



### Note!

Do not touch the bulb with your bare fingers! Use a tissue or similar.

## ENGLISH

## Electrical connection: Rallye 3003: Page 8/9

Install the relay with the connection terminals facing downwards and protected against splashing. If required and permitted by legal regulations, install a switch on the dashboard. Route and connect the cables according to the

circuit diagram. When wired according to circuit diagram **I** the auxiliary lamps are switched on together with the existing driving lamps. According to circuit diagram **II** the auxiliary lamps are switched on addition to the existing

headlamps via a separate switch. According to circuit diagram **III** the CELIS® position lamps are connected and switched on together with the parking light. Fasten the supply cables securely in place.

**Have the driving lamps set by a specialist garage or at a service station.**

**Only correctly set headlamps ensure optimum light.**

### Another tip:

- Always keep headlamp lenses clean. Dirt can swallow up to 80% of light power. You drive safely when you can see and be seen well. Do you carry spare

bulbs and fuses in your vehicle?

- Correctly re-install all the removed parts. If you have any questions or installation problems, please call the Hella Service,

wholesaler, or return to your garage.

- Outside normal working hours, an answering machine will record your inquiries and requests and Customer Services will then get back to you.

Ask your dealer for the complete Hella brochure or write to:

**Hella KGaA  
Hueck & Co.  
59552 Lippstadt/  
Germany**