

Congratulations on your purchase of the popular M6 Chain Tensioner for Harley Davidson Big Twin Motorcycles ('07 - Up) and '06 Dyna Models. Some of the benefits you'll expect with the M6 Chain Tensioner installed in your primary case are: automatically self-adjusts the tension on the primary chain, provides constant and even tension improving your transition in gear shifting, reduces shifting noise, and creates a much smoother ride, as well as extends the life of your primary chain.

*The M6 truly is, a performance product that performs!*

## FOR '07 - UP & '06 DYNA MODELS

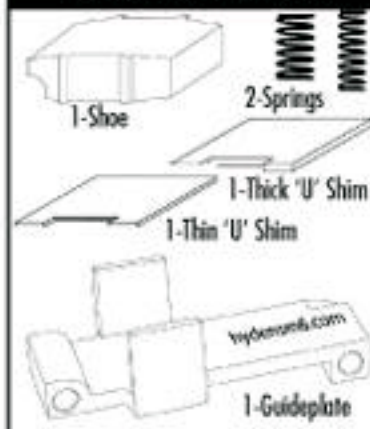

### NOTES & EXCEPTIONS

- ∞ It is possible a new chain will reach the 3/8" measurement without using any shims.
- ∞ The M6 does not require any special brand of primary fluid. It has been proven that the primary fluid currently in your bike will be acceptable with our M6 and its components.
- ∞ When adding shims, always add the "thin" shim first, remeasure the spring compression, and add additional thicknesses as needed.
- ∞ If you should notice a "whirling" sound from the primary, it is merely the chain gliding over our nylon shoe as the links seat themselves. This sound usually disappears within the first 500 miles.
- ∞ Once your chain has seated itself into the shoe and the rollers have made contact, there is usually an additional 1/16" added to the spring compression measurement.



*"Feel the difference"*

### STEP 1

Put your bike in neutral. Drain your oil and remove the engine's primary case cover.



### STEP 2

Remove the factory primary chain tensioner, along with any spacers that may be included on the back side. Keep the two stock bolts for installation of the M6.



### STEP 3

Place the smaller spring inside the larger spring and place them in the hole in the bottom of the shoe. With the smooth surface facing up and the circular cutout facing forward, on the SHOE place the shoe and springs into the guideplate and slide it into place under the primary chain. (Installation note: It may be necessary to start on the clutch side of the primary case and slide the M6 forward, or to the center, and into final location.)



### STEP 4

Using the two stock mounting bolts from the factory unit, mount the M6 tensioner to the inner primary. Torque the bolts to spec as per your model owner's manual. Measure for the 3/8" spring compression area, from the *bottom of the SHOE* to where the springs are setting on the guideplate. If this measurement is too loose, you will need to add a shim under the springs. Continue this process until the 3/8" measurement is reached. It is possible a new chain will reach the 3/8" measurement without using any shims. If you need more than the supplied shims, this may indicate that your primary chain is worn and should be replaced.



**NOTE:** The 3/8" is measured from the bottom of the shoe to the resting point of the springs on the guideplate, or shims.

### STEP 5

Re-assemble the engine's primary case and add fluid as recommended by Harley Davidson. We suggest that you replace the gaskets, if necessary. Check the unit for wear every 20,000 miles depending on your riding style...and always use clean primary fluid.



**NOTE:** At some point in time you will have chain "stretch" and will need to add an additional shim. Save your extra shims and instruction sheet for future use. Please call us if you need replacements.