

# GTK150 TWEETER KIT

## KIT CONTENTS

- 2 - GTK150 1.5" 4 OHM TWEETER MODULES
- 2 - STR04-50 12DB CROSSOVERS
- 1 - INSTALLATION KIT



## INSTALLATION INSTRUCTIONS

1. TURN THE IGNITION SWITCH OFF.
2. REMOVE THE FRONT FAIRING COVER, NOTING WHICH HOLE EACH SCREW COMES FROM.  
**TIP:** REFER TO MANUFACTURER INSTRUCTIONS IF NECESSARY, AND DON'T FORGET TO COVER YOUR FENDER.
3. CHOOSE YOUR MOUNTING LOCATION. REMOVE STOCK GAUGES OR GAUGE PLUGS AND REPLACE WITH GTK150 GAUGE TWEETERS.
4. MOUNT CROSSOVER WITH SUPPLIED HOOK AND LOOP ADHESIVE IN SUITABLE LOCATION SUCH THAT INPUT AND OUTPUT WIRES WILL REACH TWEETER WIRES AND SPEAKER WIRES.
5. CONNECT TWEETER WIRES TO CROSSOVER.
6. DISCONNECT SPEAKER WIRES FROM SPEAKERS TERMINALS.
7. REFERRING TO FIGURE 2, CONNECT CROSSOVER WIRES TO SPEAKER TERMINALS (A).  
**TIP:** IF SPEAKER WIRES WITH FACTORY CONNECTORS ARE NO LONGER AVAILABLE, (E.G. HAVE BEEN CUT) SPLICE WIRES INTO SOUND SYSTEM OUTPUT.
8. PLUG THE DISCONNECTED SPEAKER WIRES INTO THE INPUT SPADE CONNECTORS (B)
9. PERFORM A SYSTEM AUDIO TEST. TURN THE KEY TO THE ACCESSORY POSITION AND VERIFY THAT ALL COMPONENTS FUNCTION PROPERLY.
10. RE-INSTALL THE FAIRING COVER.  
**TIP:** REFER TO MANUFACTURER INSTRUCTIONS IF NECESSARY.

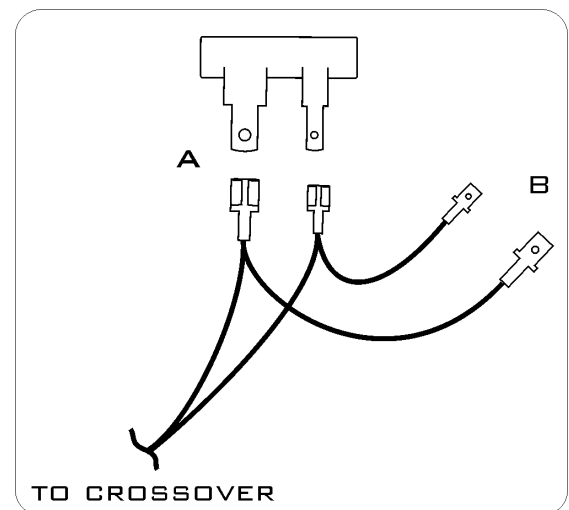

FIGURE 2