

# LOCK & DOCK

Lower Faring Door System, Harley Davidson FLH 2014 +

## Installation /Assembly Instructions

### To Install On Vehicle:

Install the Lock & Dock door assembly by removing the factory cover from the faring pocket and inserting the tabs into the slot as shown.

When opened, the door will hook in place and stay on the lower faring. The latch can be used with or without locking.

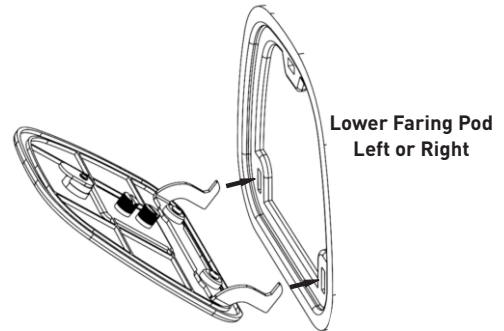

### To Install Other Accessories:

Remove the logo plate by unscrewing the thumb screws from the inside of the door assemblies. Keep the Thumb screws/O-rings for the installation of other accessories.

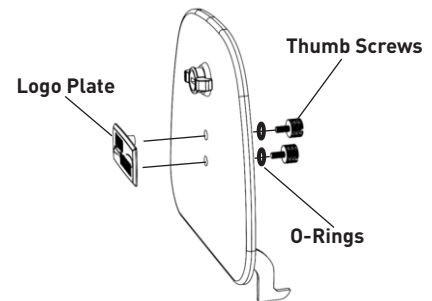

### Lock & Dock Cup Holder Installation:

To install the optional Lock & Dock Cup Holder assembly: First install the soft cup holder onto the cast parts by wrapping the flaps around the cup holder ring and fastening the snaps.

Now insert the cup holder posts into the Lock & Dock Door assembly and fasten with the thumb screws/o-rings.

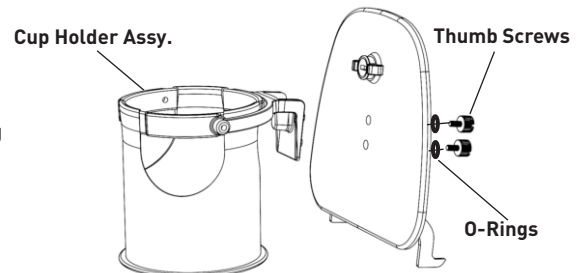

### Lock & Dock Challenge Coin Mount:

To install the optional Lock & Dock Challenge Coin Mount assembly:

First install the Challenge Coin (not included) into the base, then install the front on and secure with the set screw. **NOT: Do not over tighten the set screw. NOTE: Use double stick tape on back of coin if coin thickness is an issue for installation, use multiple layers as required.**

Now insert the Challenge Coin Mount posts into the Lock & Dock Door assembly and fasten with the thumb screws/o-rings.

