



Quick Detach Saddlebag Brackets

KEY CODE NUMBER _____
(Save this number for future key identification)

Applications Model VTX-C1BR Rev.11/23/15

Honda VTX -VTX C Model with Hondaline Backrest

Before you begin, read these instructions and check to be sure all parts are accounted for.

<u>Qty.</u>	<u>Part Description</u>
2	Easy Brackets (ID number 17, stamped on brackets)
2	Docking Plate
2	3/8 Docking Post Spacer Combination (front)
2	3/8 Docking Post (rear)
4	3/8 Polished SS Socket Head Bolt
8	3/8 x 1 Black Button Head Bolt
12	3/8 Nylon Locking Nut
8	3/8 Fender Washers
2	Key

Installation Instructions

1. Remove the backrest from the motorcycle. Complete disassembly of the backrest may be required for reattachment to the motorcycle.
2. Install the docking plate to the RH side of the backrest using the front docking post and rear docking post attached with (1) 3/8 polished SS button head bolt and (1) 3/8 nylon locking nut each. Torque to 12 ft. lbs. (See fig 1 and fig 2) **Note:** Install the docking plate with the white strips facing the fender on the top and to the rear. Center the middle hole in the plate so the 10 mm spacer will fit in the hole when you reattach the backrest to the motorcycle.
3. Repeat steps 1 and 2 on the LH side of the backrest. Reinstall the backrest on the motorcycle.
4. Install the EASY BRACKETS on the docking posts. (See fig 3) **Note:** Use the key provided to open the cam lock prior to installation on the docking posts. The key can not be removed until the cam lock is fully engaged under the docking post.
5. Hold the RH saddlebag against the EASY BRACKET. Position the saddlebag as desired noting the clearances from the seat, turn signals and any lower obstructions such as chain guards, axle nuts, and etc. Mark the outer edge of the bracket on the saddlebag. Remove the EASY BRACKET from the motorcycle.
6. Place the bracket on the saddlebag within the outline and drill the 4 holes for mounting.(See fig 4) Attach the bracket to the saddlebag using the (4) 3/8 x 1 black button head bolts, (4) 3/8 fender washers and (4) 3/8 Nylon locking nuts (**All 4 mounting points MUST be utilized**). Install the completed RH saddlebag with EASY BRACKETS on the motorcycle. **Note: The cam lock must be fully engaged and the key removed to ensure the EASY BRACKETS are properly installed and ready for use.**
7. Repeat steps 4, 5 and 6 on the LH side of the backrest.

Notice to Consumer

Do NOT exceed 15 lbs. of total weight on the EASY BRACKET saddlebag removal system.

Neither the manufacturer nor the distributor or retailer of the EASY BRACKETS makes any express warranties of any kind with respect to the EASY BRACKETS. Any implied warranty does not cover defects caused by modification or alterations of the EASY BRACKETS or caused by physical abuse to or misuse of the EASY BRACKETS or its use and/or operation in a manner contrary to the accompanying instructions. Failure to install and/or use the EASY BRACKETS in the manner described by the accompanying instructions shall render all warranties, expressed and/or implied, void and release the manufacturer, distributor and retailer from any and all liability arising from the use of the EASY BRACKETS.

Do not return product without prior authorization.

SEE REVERSE SIDE FOR ILLUSTRATIONS

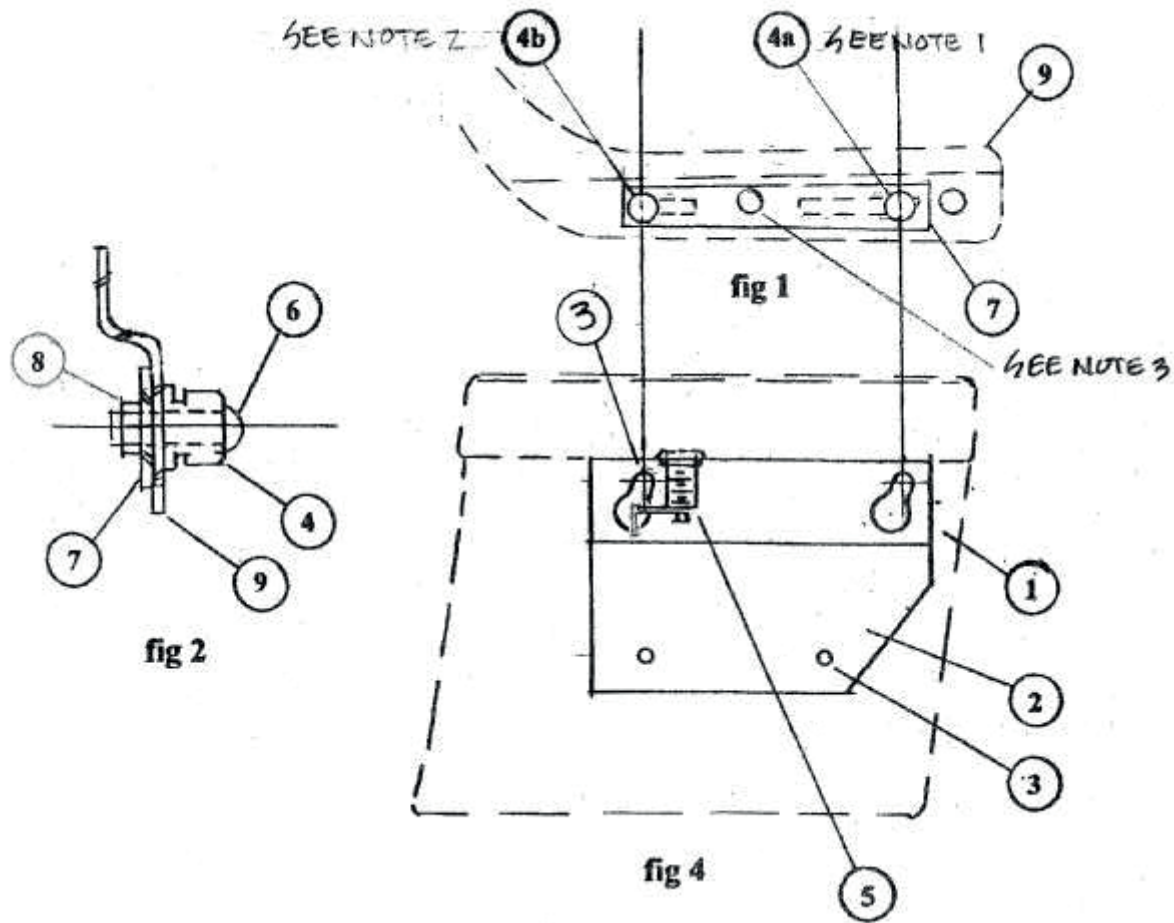

- 1 Saddlebag (by others)
- 2 EASY BRACKET
- 3 3/8" holes (total of 4) Use to mount EASY BRACKET to saddlebag. Locate large washer under nylock nut inside saddlebag.
- 4a Forwardmost docking post
- 4b Rearmost docking post
- 5 Cam lock. Cam lock must be fully engaged and barrel key removed to ensure brackets are properly installed and ready for use.
- 6 Docking post bolt. (sizes vary)
- 7 Docking Plate
- 8 Nylock nut
- 9 Backrest

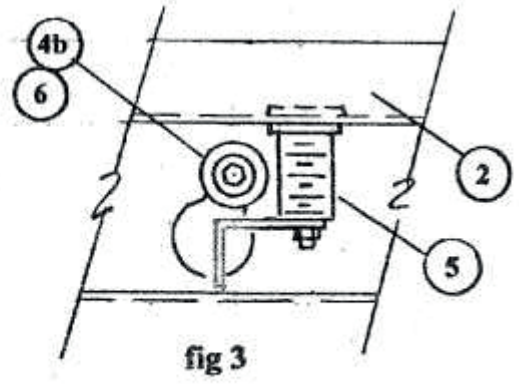

fig 3

NOTES:

1. FORWARD DOCKING POST IS LARGEST WITH SPACER THAT FITS INTO BACKREST SLOT.
2. REAR DOCKING POST IS SMALLEST AND DOES NOT FIT INTO BACKREST SLOT.
3. DOCKING PLATE MOUNTS BEHIND BACKREST WITH THE CENTER HOLE OVER BACKREST SPACER

VTX-C1BR



Hondaline Backrest

For kits VTX-C1BR and VTX-C1BR-1

Backrest not provided, must be purchased separately. The docking posts attach to the backrest. This kit comes with a special mounting plate for installation on the backrest.

