



### Quick Detach Saddlebag Brackets

**KEY CODE NUMBER** \_\_\_\_\_  
(Save this number for future key identification)

**Applications Model VTX-C1BR-1** Rev.11/23/15  
Honda VTX -VTX C Model with Hondaline Backrest

Before you begin, read and understand these instructions and check to be sure all parts are accounted for.

<b><u>Qty.</u></b>	<b><u>Part Description</u></b>
2	Easy Brackets (ID number 17, stamped on brackets)
2	Docking Plate
2	3/8 Docking Post Spacer Combination (front)
2	3/8 Docking Post (rear)
4	3/8 Polished Button Head Bolt
8	3/8 x 1 Black Button Head Bolt
8	3/8 Nylon Locking Nut
8	3/8 Fender Washers
2	Key

### **Installation Instructions**

1. Remove the backrest from the motorcycle. **Note:** To avoid movement of the fender during removal of the backrest, loosen the front fender bolts first. Do not remove. Next remove the rear fender bolts and tip the backrest forward to allow reinstallation of the rear fender bolts. Finally remove the front fender bolts, remove the backrest and temporarily reinstall the front fender bolts. Reverse this procedure during reinstallation of the backrest.
2. Install the docking plate to the inside of the RH backrest using the front docking post, the rear docking post, the 3/8" polished button head bolts and the docking plate. Do not tighten the bolts until the backrest is reinstalled on the motorcycle. Center the middle hole in the plate so the 10 mm bolt and spacer will fit in the hole when you reattach the backrest to the motorcycle.
3. Repeat steps 1, and 2 on the LH side of the backrest. Reinstall the backrest on the motorcycle. Tighten the 3/8" bolts at the docking posts. Torque to 12 ft. lbs.
4. Install the EASY BRACKETS on the docking posts. **Note:** Use the key provided to open the cam lock prior to installation on the docking posts. The key can not be removed until the cam lock is fully engaged under the docking post.
5. Hold the RH saddlebag against the EASY BRACKET. Position the saddlebag as desired noting the clearances from the seat, turn signals and any lower obstructions such as chain guards, axle nuts, and etc. Mark the outer edge of the bracket on the saddlebag. Remove the EASY BRACKET from the motorcycle.
6. Place the bracket on the saddlebag within the outline and drill the 4 holes for mounting. Attach the bracket to the saddlebag using the (4) 3/8 x 1 black button head bolts, (4) 3/8 fender washers and (4) 3/8 Nylon locking nuts (**All 4 mounting points MUST be utilized**). Install the completed RH saddlebag with EASY BRACKETS on the motorcycle. **Note: The cam lock must be fully engaged and the key removed to ensure the EASY BRACKETS are properly installed and ready for use.**
7. Repeat steps 4, 5, and 6 on the LH side of the backrest.

### **Notice to Consumer**

**Do NOT exceed 15 lbs. of total weight on the EASY BRACKET saddlebag removal system.**

Neither the manufacturer nor the distributor or retailer of the EASY BRACKETS makes any express warranties of any kind with respect to the EASY BRACKETS. Any implied warranty does not cover defects caused by modification or alterations of the EASY BRACKETS or caused by physical abuse to or misuse of the EASY BRACKETS or its use and/or operation in a manner contrary to the accompanying instructions. Failure to install and/or use the EASY BRACKETS in the manner described by the accompanying instructions shall render all warranties, expressed and/or implied, void and release the manufacturer, distributor and retailer from any and all liability arising from the use of the EASY BRACKETS.

**Do not return product without prior authorization.**

**SEE REVERSE SIDE FOR ILLUSTRATIONS**

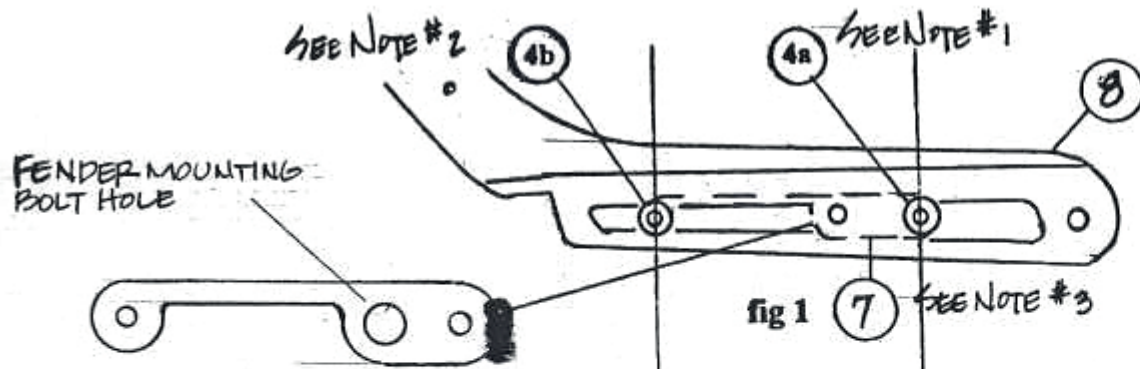

NOTE POSITION OF DOCKING PLATE BEHIND BACKREST

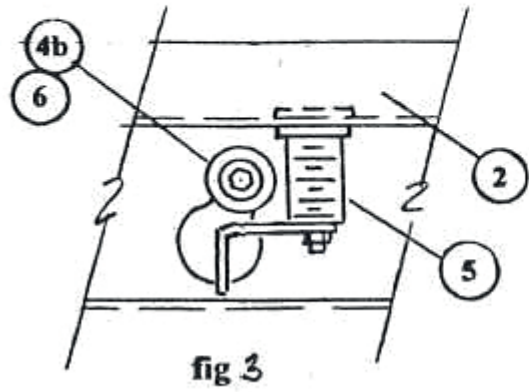
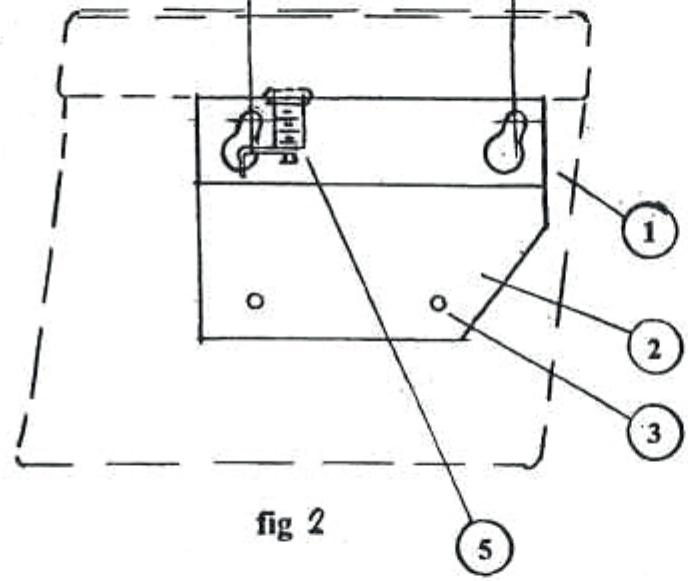

- 1 Saddlebag (by others)
- 2 EASY BRACKET
- 3 3/8" holes (total of 4) Use to mount EASY BRACKET to saddlebag. Locate large washer under nylock nut inside saddlebag.
- 4a Forwardmost docking post
- 4b Rearmost docking post
- 5 Cam lock. Cam lock must be fully engaged and barrel key removed to ensure brackets are properly installed and ready for use.
- 6 Docking post bolt. (sizes vary)
- 7 DOCKING PLATE
- 8 BACKREST

NOTES

1. FORWARD DOCKING POST IS LARGEST AND THE REAR SPACER FITS IN THE BACKREST SLOT
2. REAR DOCKING POST IS SMALLEST AND DOES NOT FIT INTO THE SLOT
3. DOCKING PLATE MOUNTS BEHIND THE BACKREST WITH THE CENTER HOLE ALIGNED OVER THE BACKREST SPACER.

VTX-CIBR-1



### Hondaline Backrest

For kits VTX-C1BR and VTX-C1BR-1

Backrest not provided, must be purchased separately. The docking posts attach to the backrest. This kit comes with a special mounting plate for installation on the backrest.

