



Quick Detach Saddlebag Brackets

KEY CODE NUMBER _____
(Save this number for future key identification)

Applications Model VC1700-R1CBR Rev.11/20/15

Kawasaki Vulcan 1700 Classic with Cobra backrest

Before you begin, read and understand these instructions and check to be sure all parts are accounted for.

<u>Qty.</u>	<u>Part Description</u>
2	Easy Brackets (ID number 6, stamped on brackets)
4	Docking Post
4	8mm SS Socket Head Bolt
4	8mm SS Button Head Bolt
6	Small SS Spacers
2	Large SS Spacers
8	3/8 x 1 Black Button Head Bolts
8	3/8 Nylon Locking Nuts
8	3/8 Fender Washers
2	Keys

Installation Instructions Note: It is recommended to use Loctite on all bolt installations.

1. This kit comes with (4) new spacers, (2) small and (2) large, to replace the spacers between the Cobra side rails and the fender. These replacement spacers are necessary to create a proper alignment for the Easy Bracket docking posts. Also included are (4) small spacers to be used between the backrest side plate and the vertical backrest bars.
2. First loosen the two side bolts that hold the backrest pad in place so the backrest can flex easier. Next remove the backrest from the RH side plate by removing the two bolts. While holding the backrest, remove the bolts at the LH side plate.
3. Remove the side plate on the RH side of the motorcycle. Remove one side plates at a time to avoid movement of the fender. The Cobra spacers and screws will not be reused for this application. Next reinstall the side plate with the Easy Bracket docking post. At the front hole, place a small spacer between the fender rail and the side plate. Place a docking post on the 8mm SS socket head bolt and insert through the side plate and spacer. Leave the bolt loose and repeat at the rear hole using a large spacer. Leave this bolt loose as well. Repeat the procedure on the LH side of the motorcycle.
4. Now we are ready to reinstall the backrest. The backrest will attach to the side plates using (4) small spacers and (4) SS button head bolts. The spacers will be installed between the side plate and the vertical backrest riser with the bolts installed from outside the side plate. Leave all bolts loose at this time. If you have the Cobra luggage rack it will be installed between the backrest riser and the spacers. Moving from one side to the other and from one bolt to another, tighten all bolts to approximately 15 foot pounds. Tighten the bolts holding the pad to the backrest.
5. Install the EASY BRACKETS on the docking posts. **Note:** Use the key provided to open the cam lock prior to installation on the docking posts. The key can not be removed until the cam lock is fully engaged under the docking post.
6. Hold the RH saddlebag against the EASY BRACKET. Position the saddlebag as desired noting the clearances from the seat, turn signals and any lower obstructions such as chain guards, axle nuts, and etc. Mark the outer edge of the bracket on the saddlebag. Remove the EASY BRACKET from the motorcycle.
7. Place the bracket on the saddlebag within the outline and drill the 4 holes for mounting. Attach the bracket to the saddlebag using the (4) 3/8 x 1 black button head bolts, (4) 3/8 fender washers and (4) 3/8 Nylon locking nuts (**All 4 mounting points MUST be utilized**). Install the completed RH saddlebag with EASY BRACKETS on the motorcycle. **Note: The cam lock must be fully engaged and the key removed to ensure the EASY BRACKETS are properly installed and ready for use.**
8. Repeat steps 5, 6 and 7 on the LH side of the motorcycle.

Notice to Consumer

Do NOT exceed 15 lbs. of total weight on the EASY BRACKET saddlebag removal system.

Neither the manufacturer nor the distributor or retailer of the EASY BRACKETS makes any express warranties of any kind with respect to the EASY BRACKETS. Any implied warranty does not cover defects caused by modification or alterations of the EASY BRACKETS or caused by physical abuse to or misuse of the EASY BRACKETS or its use and/or operation in a manner contrary to the accompanying instructions. Failure to install and/or use the EASY BRACKETS in the manner described by the accompanying instructions shall render all warranties, expressed and/or implied, void and release the manufacturer, distributor and retailer from any and all liability arising from the use of the EASY BRACKETS.

Do not return product without prior authorization.

SEE REVERSE SIDE FOR ILLUSTRATIONS

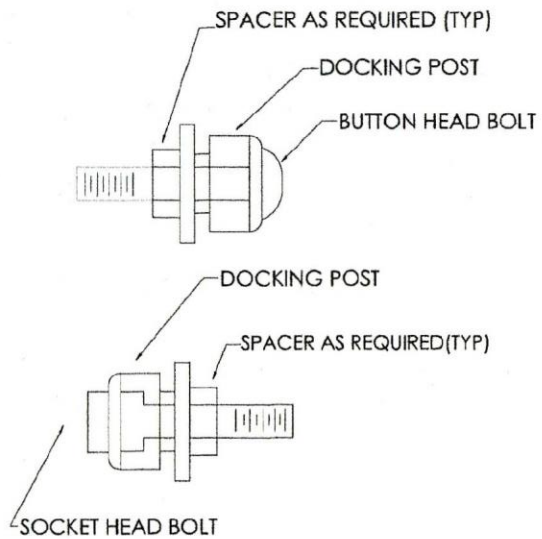

TYP BOLT/DOCKING POST

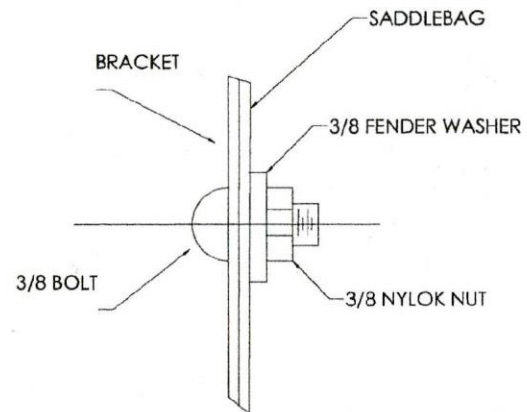

DETAIL B

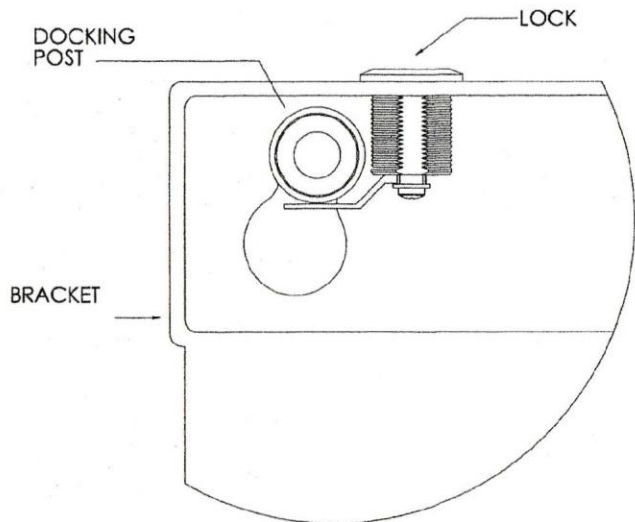

DETAIL A

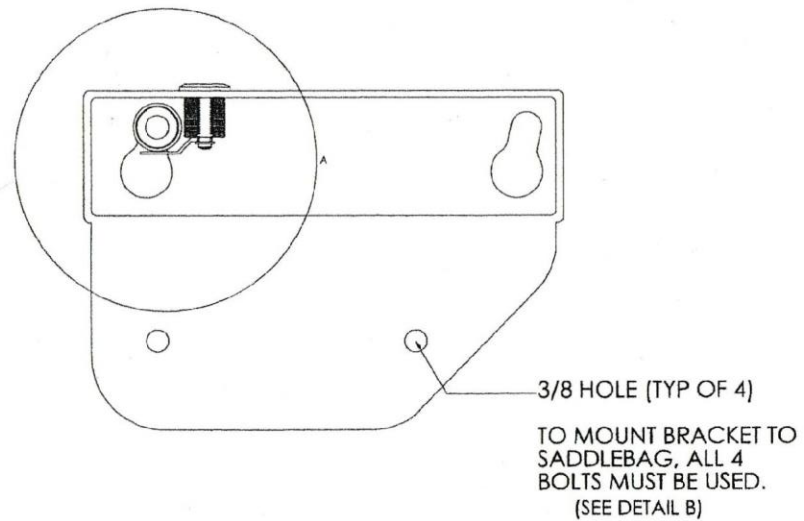

TYPICAL DETAILS