



## TURN SIGNAL RELOCATION KIT for Harley Davidson

**DYNAS: FXDWG & FXDF**

**SOFTAILS: FXST, FXSTC, FXSTB, FXSTS, FLSTSB**

### Applications

**Model: TSDWG-01 & TSDWG-02**

**Model: TSFXST-01 & TSFXST-02**

Before you begin, read these instructions and check to be sure all parts are accounted for.

<u>Qty.</u>	<u>Part Description</u>
2	Relocation Bracket
2	5/16" Hex Head Bolt
4	5/16" Flat Washers
2	5/16" Lock Washer
4	1/4" SS Button Head Bolt
4	1/4" Flat Washers
4	1/4" Nylock Nut

### Installation Instructions

**Note:** It is highly recommended a licensed technician be consulted prior to beginning installation of the turn signal relocation kit.

1. Remove the turn signals from the motorcycle. If the turn signals are mounted to the motorcycle with a single post standoff, a wing style standoff will need to be purchased. HD part number 68480-93. See reverse side for Turn Signal Connector Removal instructions.
2. Install the relocation brackets and the license plate and frame to the license plate mount using the 1/4" SSBH bolts, flat washers and nylon lock nuts. If not already done, the top holes in the plastic license plate mount will need to be drilled. The brackets are located on the outside of the plastic license plate mount and under the license plate and frame. See illustration reverse side.
3. Install the turn signals to the relocation brackets at the hole closest the bend using the provided 5/16" hex head bolts, (2) flat washers and (1) lock washer each. The wires will be routed through the front hole of the brackets. Reconnect the wires to the motorcycle. The wires must be properly secured under the fender to avoid any contact with the wheel.

### Notice to Consumer

Neither the manufacturer nor the distributor or retailer of the Turn Signal Relocation Kit makes any express warranties of any kind with respect to the Turn Signal Relocation Kit. Any implied warranty does not cover defects caused by modification or alterations of the Turn Signal Relocation Kit or caused by physical abuse to or misuse of the Turn Signal Relocation Kit or its use and/or operation in a manner contrary to the accompanying instructions. Failure to install and/or use the Turn Signal Relocation Kit in the manner described by the accompanying instructions shall render all warranties, expressed and/or implied, void and release the manufacturer, distributor and retailer from any and all liability arising from the use of the Turn Signal Relocation Kit.

**Do not return product without prior authorization.**

**SEE REVERSE SIDE FOR ILLUSTRATIONS**



## TURN SIGNAL RELOCATION KIT INSTALLED HD DYNA (SOFTAILS SIMILAR)

### Turn Signal Connector Removal

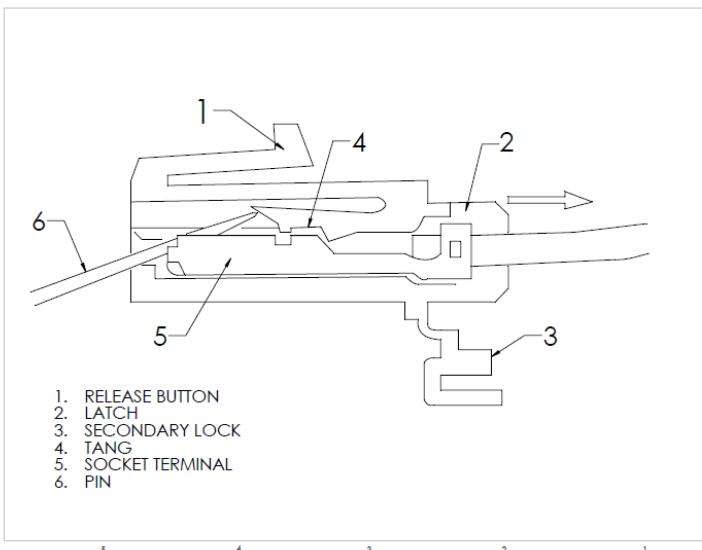

1. After removal of the tail light lens, disconnect the turn signal connector from the electrical terminal by depressing the Release button. (1)
2. Open the Secondary lock. (3) Note the wire color locations for correct reconnection.
3. Using a Pin or small screw driver (6) release the Tang (4) from the Socket terminal (5) while gently pulling the wire from the connector.
4. Reverse the procedure for reconnection.