



### Quick Detach Saddlebag Brackets

**KEY CODE NUMBER** \_\_\_\_\_  
(Save this number for future key identification)

### Applications Model CHF-R2DB

Rev 4/7/17

2014 and Later Indian Chief Classic / 2016 and Later Dark Horse with OEM Detachable Backrest (Not Provided)

Before you begin, read and understand these instructions and check to be sure all parts are accounted for.

| <u>Qty.</u> | <u>Part Description</u>                           |
|-------------|---|
| 2           | Easy Brackets (ID number 27, stamped on brackets) |
| 2           | Smaller Docking Posts                             |
| 2           | Larger Docking Posts                              |
| 4           | 8mm Polished SS Socket Head Bolt                  |
| 8           | 3/8 x 1 Black Button Head Bolt                    |
| 8           | 3/8 Nylon Locking Nut                             |
| 8           | 3/8 Fender Washers                                |
| 2           | Keys  |

### Installation Instructions **Note: It is recommended to use Loctite on all bolt installations.**

1. After installation of the backrest (not provided) remove the backrest and then remove the fender bolts at the backrest mounting hardware from the RH side of the fender. **Note:** Remove and replace (1) bolt at a time to avoid movement of the fender.
2. Using the shorter 8mm polished SS socket head bolt and the docking post with the narrow collar, mount the docking post to the outside of the front backrest mount and using the longer 8mm polished SS socket head bolt mount the docking post with the wider collar on the outside of the rear backrest mount. (note: base of the docking posts will fit into the backrest mounting spools) Torque to 17 ft. lbs.
3. Repeat steps 1 and 2 on the LH side of the fender.
4. Install the EASY BRACKETS on the docking posts. **Note:** Use the key provided to open the cam lock prior to installation on the docking posts. The key can not be removed until the cam lock is fully engaged under the docking post.
5. Hold the RH saddlebag against the EASY BRACKET. Position the saddlebag as desired noting the clearances from the seat, turn signals and any lower obstructions such as chain guards, axle nuts, and etc. Mark the outer edge of the bracket on the saddlebag. Remove the EASY BRACKET from the motorcycle.
6. Place the bracket on the saddlebag within the outline and drill the 4 holes for mounting. Attach the bracket to the saddlebag using the (4) 3/8 x 1 black button head bolts, (4) 3/8 fender washers and (4) 3/8 Nylon locking nuts (**All 4 mounting points MUST be utilized**). Install the completed RH saddlebag with EASY BRACKETS on the motorcycle. **Note: The cam lock must be fully engaged and the key removed to ensure the EASY BRACKETS are properly installed and ready for use.**
7. Repeat steps 4, 5, and 6 on the LH side of the fender.

### Notice to Consumer

**Do NOT exceed 15 lbs. of total weight on the EASY BRACKET saddlebag removal system.**

Neither the manufacturer nor the distributor or retailer of the EASY BRACKETS makes any express warranties of any kind with respect to the EASY BRACKETS. Any implied warranty does not cover defects caused by modification or alterations of the EASY BRACKETS or caused by physical abuse to or misuse of the EASY BRACKETS or its use and/or operation in a manner contrary to the accompanying instructions. Failure to install and/or use the EASY BRACKETS in the manner described by the accompanying instructions shall render all warranties, expressed and/or implied, void and release the manufacturer, distributor and retailer from any and all liability arising from the use of the EASY BRACKETS.

**Do not return product without prior authorization.**

**SEE REVERSE SIDE FOR ILLUSTRATIONS**

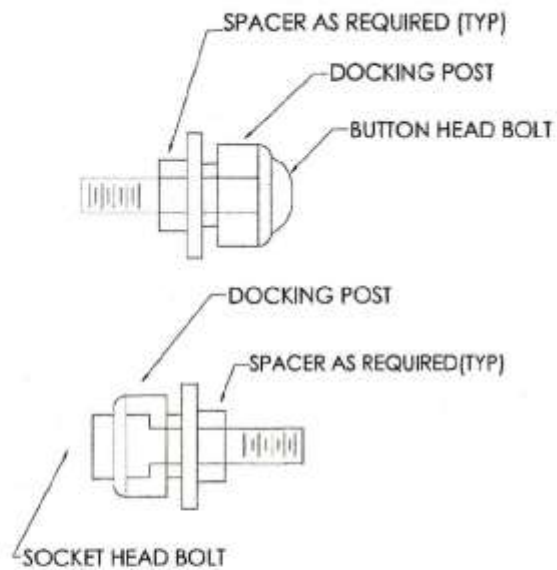

TYP BOLT/DOCKING POST

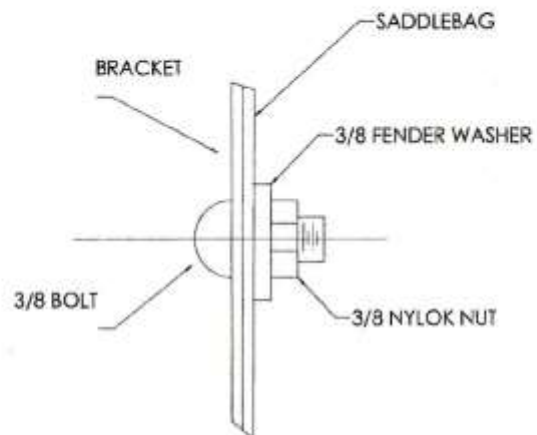

DETAIL B

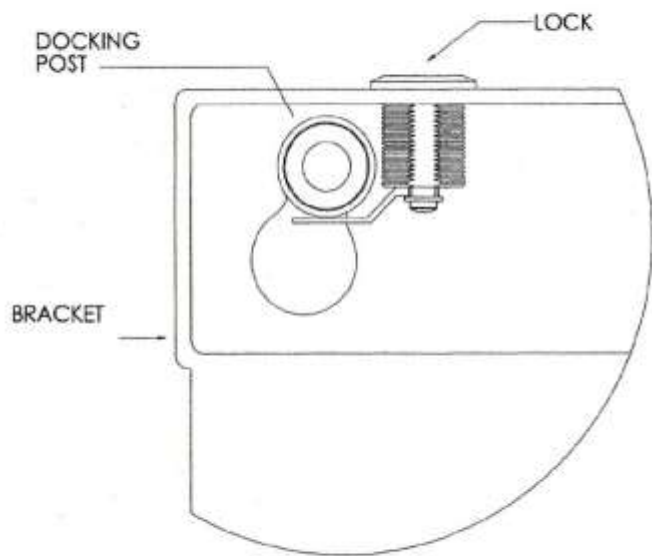

DETAIL A

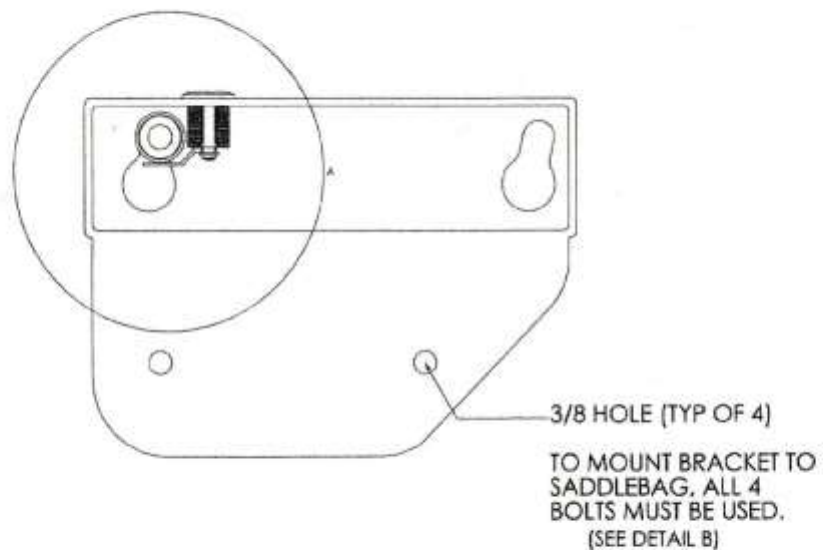

TYPICAL DETAILS