

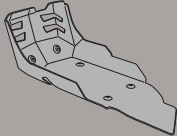







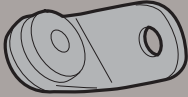

RP5103

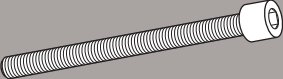
OIL CARTER PROTECTOR

BMW F800GS (2008-2012)

N°	Description	Features	Code	Quantity	
1	Oil Carter Protector			1	
2	Support		GL2134	1	
3	Support		GL2027	1	
4	Screw	TE M8x12	-	4	
5	Screw	TEF M6x30		2	
6	Screw	TCEI M8X110		1	
7	Bolt	Auto Bloccante Flangiato M6		2	
8	Spacer	Ø16x17 Rib. Ø10x10 foro 6.5mm	V623	2	
9	Washer	Zigrinata Ø8	814RONZ	5	
10	Washer	Ø6x18	-	2	
11	Fairleader	Z268		2	
12	Silent Block			4	

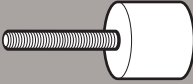
RP5103

OIL CARTER PROTECTOR

BMW F800GS (2008-2012)

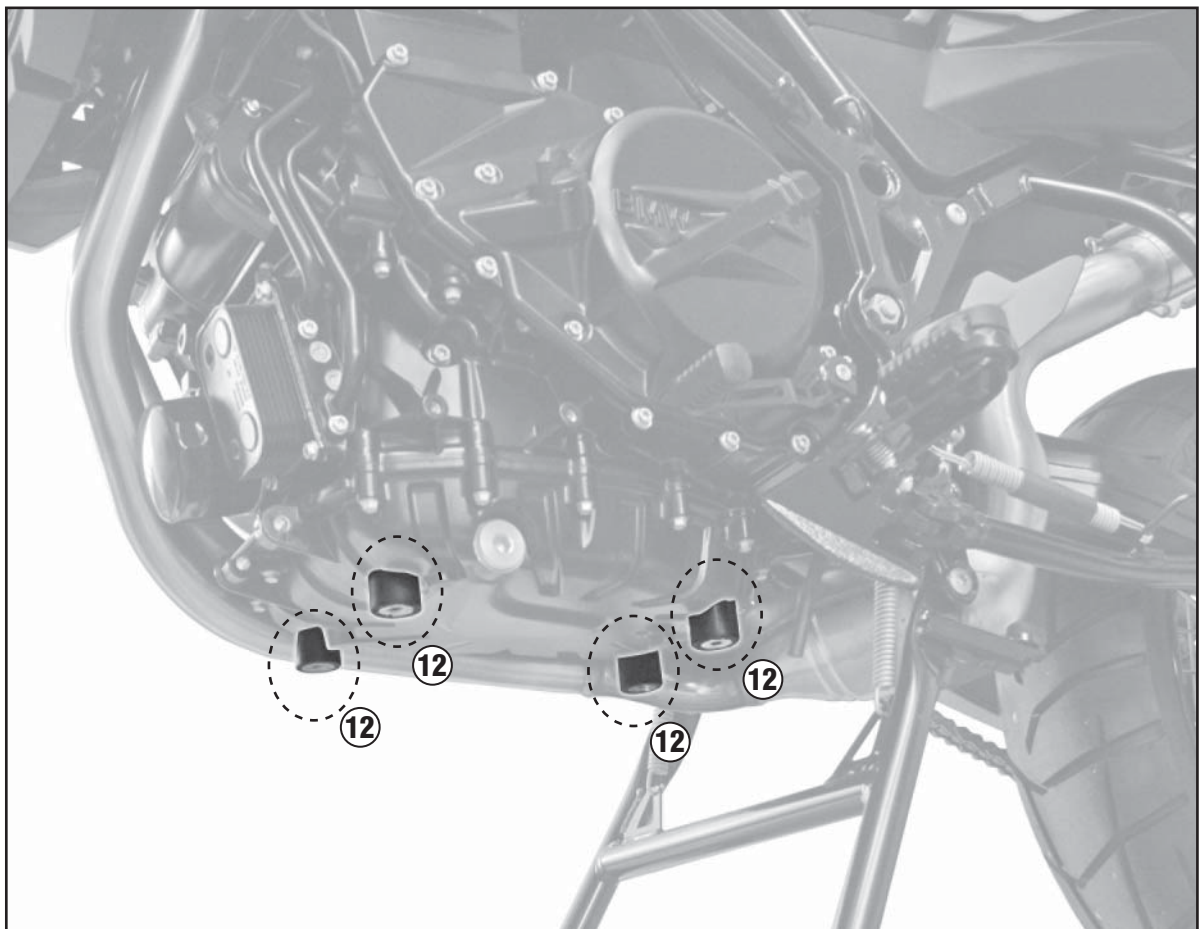
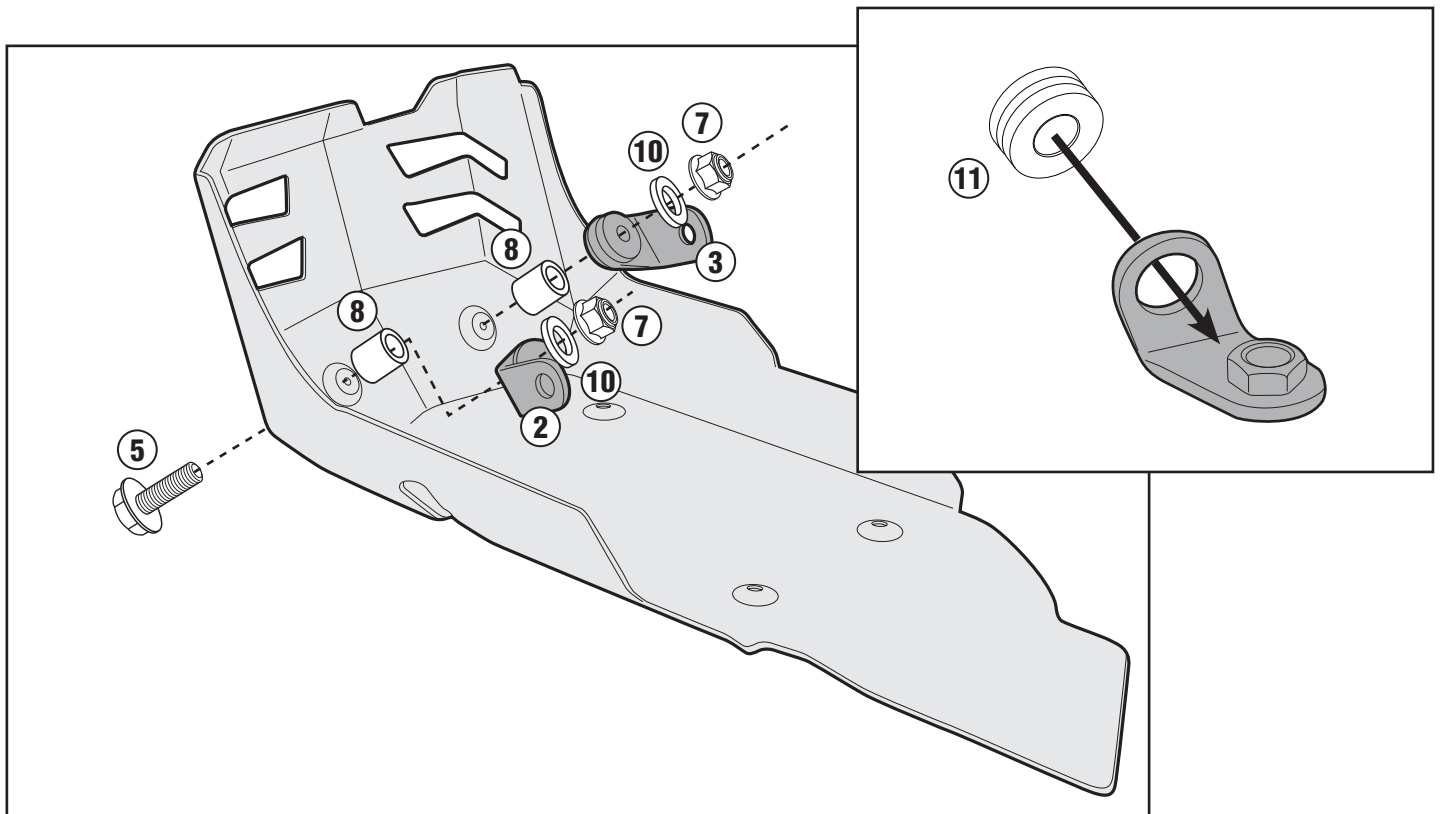

RP5103

OIL CARTER PROTECTOR

BMW F800GS (2008-2012)

