



4-Stroke Header Installation Instructions

Thank you for choosing FMF as your performance aftermarket exhaust. We have spent countless hours of R&D and testing to ensure you receive the highest quality product on the market today.

All FMF products are developed using the most current technology available for design and manufacturing. Every exhaust is made 100% at the Flying Machine Factory in Southern California. We use only the highest quality American materials for function and durability.

Since 1973, FMF has been bringing you the very best in bolt on performance. Our products are specifically engineered to broaden your existing powerband and give you an all around power increase with substantial weight savings. Bolt on FMF and **FEEL THE POWER!**

ATTENTION

This product is designed for closed course use only unless otherwise stated and not intended to meet emission regulations for use on public lands, roads, or access routes - consult with local jurisdictions.

Please read all instructions thoroughly before installation. Failure to follow all installation instructions will void any warranty implied or otherwise. FMF Racing is not responsible for problems due to improper installation and/or improper use.

Before you begin installing this product, we recommend wearing safety glasses and mechanics gloves. You must know how to remove and replace your stock exhaust in order to install this FMF product otherwise have it installed by a professional mechanic. Keep all stock parts from your existing system as some components may be necessary to install your new FMF exhaust depending on the application.

Parts Supplied

- (1) FMF Header
- (1) applicable hardware kit

Tools Required

various wrenches
contact cleaner
High Temp silicone

Removal and Pre-Installation

1. Make sure engine is completely cool prior to installation and the vehicle is in stable position.
2. Remove the muffler (see instructions for removing muffler or refer to your service manual).
3. Remove hardware attaching stock header to the exhaust port. Note the stock mounting hardware will be necessary to mount the FMF header for most applications.
4. Gently remove the header. On some models, you may need to remove other components to access the header. Keep the existing exhaust port gasket as it will be reused if in good condition (minimal cracks, no tears) otherwise replace with a new gasket.
5. Using contact cleaner, clean the exhaust port or flange where the header connects. Allow to dry then lightly coat with a bead of high temp silicone for an improved seal.

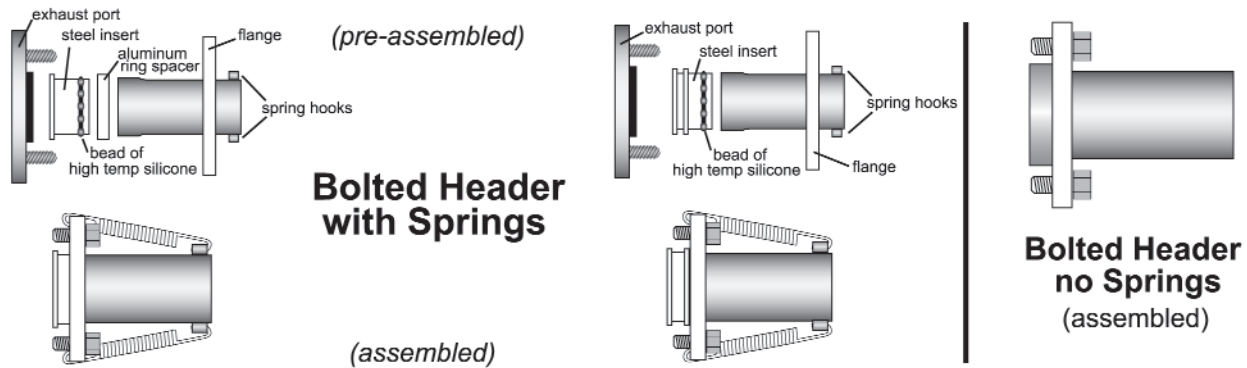

Installation

6. Align the FMF header into position and re-install following the applicable illustration above. Do not tighten at this time. Note: Use a spring puller tool to install the exhaust springs where applicable. Springs are attached after the mounting hardware has been installed.
 7. Using contact cleaner, clean the slip-fit section of the header where the muffler midpipe connects. Allow to dry then lightly coat with a bead of high temp silicone for an improved seal.
 8. Install the muffler at this time, using the instructions provided, but do not fully tighten mounting hardware.
 9. Make sure the header and muffler are in neutral positions and not binding. Slowly tighten all mounting fasteners and clamps to manufacturer's specifications, starting from the header and working to the muffler.
 10. Inspect the complete exhaust to make sure there is no contact with the frame, shock spring, engine, body panels, or any cables, hoses, or wiring. The exhaust system should only be in contact with the exhaust port and mounting points. Confirm all controls operate in accordance with the manufacturer's specifications.
- Note: Depending on application the kick starter may need to be rotated back to prevent contact with header. Also, it may be necessary to adjust the water hose from the waterpump to the radiator by rotating it to provide adequate clearance between the hose and header (minimum 1/4"). Loosen hose clamp at the waterpump just enough to allow hose to rotate then retighten once clearance is achieved. See illustration below.**
11. We recommend using high temp silicone for an improved seal. Please follow instructions for the silicone and allow sufficient time to dry before starting the engine.
 12. Start the engine and bring it up to operating temperature. Check for exhaust leaks.
 13. Let engine cool completely and retorque all mounting hardware to manufacturer's specifications.

