



Muffler insert installation and removal instructions

Please read all instructions thoroughly before installation. Failure to follow all installation instructions will void any warranty implied or otherwise. FMF Racing is not responsible for problems due to improper installation and/or improper use.

Before you begin installing this product, we recommend wearing safety glasses.

Tools Required

small flat blade screwdriver or pick
high temp silicone

Installation

1. Apply a small bead of high temp silicone to the muffler outlet where the muffler insert will be installed.
2. Carefully install the insert into the muffler making sure it is fully seated and the ring groove in the muffler outlet is visible.
3. Separate the ring coils and insert the end without the bent tab into the groove (fig. 2). Note: Be sure end of ring with bent tab is facing outward.
4. With the lower end of ring inserted into groove, slide screwdriver/pick counter-clockwise between the winds of the clip to seat completely into the groove (fig 3-4).
5. Clean the muffler canister then apply the spark arrestor decal to the top-rear of the canister.

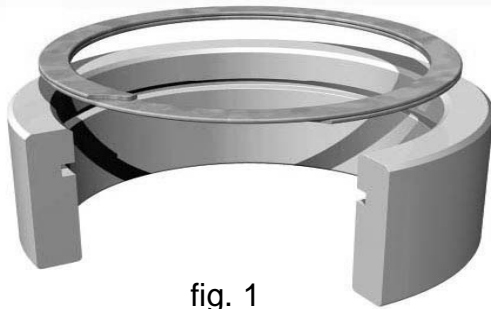

fig. 1

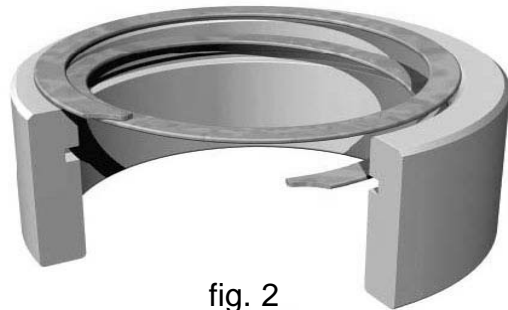

fig. 2

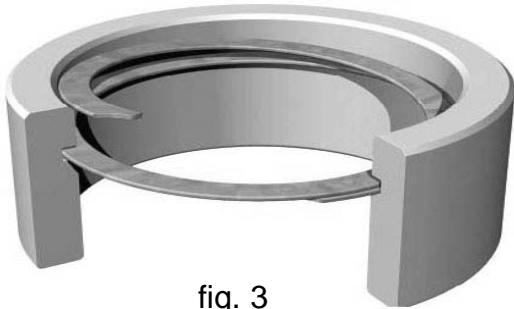

fig. 3

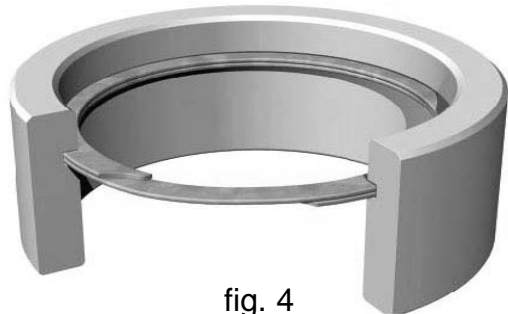

fig. 4

Removal

1. Insert a screwdriver or pick into the removal notch (fig 5).
2. Use the tool to pry out the first end of the ring.
3. With the end of the clip now above the groove (fig 3), slide the screwdriver/pick between the winds clockwise until the lower end of the clip is released from the groove (fig 1).



fig. 5