



OFF-ROAD / MOTARD HANDGUARDS

- Aluminum inner bar is wrapped in a plastic roost deflector which gives added protection from trees, brush and roost
- Comes complete with all necessary hardware to fit all 7/8" handlebars
- Optional hardware available for 1-1/8" and tapered bars
- Easy-to-mount design can be installed quickly

INSTALLATION

1. This kit will fit aluminum and steel 7/8" handlebars. For fitment on tapered and larger handlebars a larger bar clamp kit is required.
2. Depending on the configuration of the master cylinder, controls and other accessories may need to be loosened and repositioned to make room for the bar clamps.
3. Loosely fit the two-piece clamp onto the handlebar (*fig. 1*) to make adjustment easier as you install the handguards.
4. Assemble the bar end mount onto the handguard (*fig. 2*) and assemble the handguard onto the handlebar. For steel and aluminum thin wall handlebars with a large inside diameter, fit the plastic sleeve provided over the bar end mount.
5. Adjust to desired position, then tighten the clamps and bar end mounts.
6. Check for clearance of the levers and other controls. Tighten any controls that you may have loosened.

IMPORTANT! Check for throttle clearance and operation. The throttle should return normally and smoothly to the closed position. The throttle tube or grip should not contact the handguard. This could affect operation and cause injury or death.

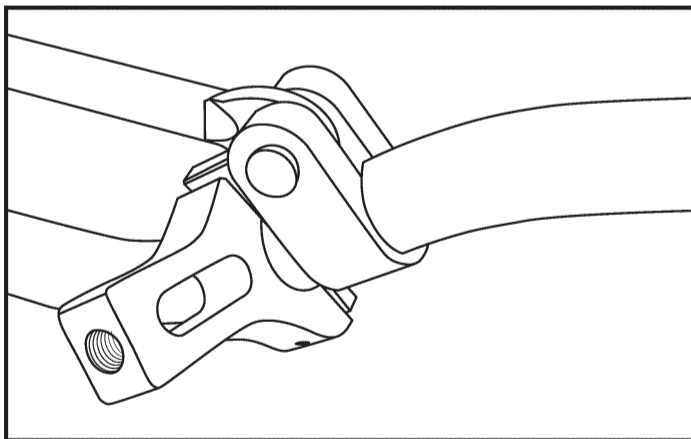

figure 1

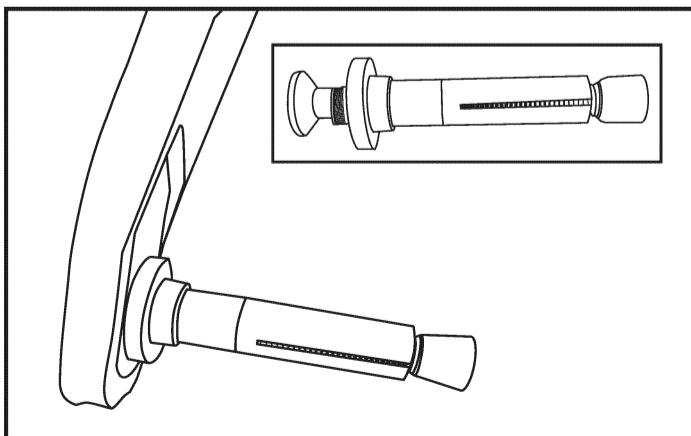

figure 2