



FEULING® THROTTLE POSITION SENSOR INSTALLATION INSTRUCTIONS



#9950



#9952

IMPORTANT NOTICE

THIS INSTALLATION SHOULD BE DONE BY AN EXPERIENCED MECHANIC WHO HAS ACCESS TO A FACTORY SERVICE MANUAL AND ALL REQUIRED TOOLS

CAUTION

INCORRECT INSTALLATION CAN CAUSE ENGINE DAMAGE NOT COVERED UNDER WARRANTY. FAILURE TO INSTALL COMPONENTS CORRECTLY CAN CAUSE ENGINE SEIZURE. ENGINE SEIZURE MAY RESULT IN SERIOUS INJURY TO MOTORCYCLE, OPERATOR, PASSENGER, AND/OR OTHERS.

CAUTION

IMPROPERLY TORQUED BOLTS MAY RESULT IN OIL LEAKS AND DISTORTION OF COMPONENTS. IF REPLACING THE ENGINES HEAD BOLTS OR STUDS ALWAYS USE NEW HEAD & BASE GASKETS

CAUTION

WHEN SERVICING THE FUEL SYSTEM, DO NOT SMOKE OR ALLOW OPEN FLAME OR SPARKS IN THE VICINITY. GASOLINE IS EXTREMELY FLAMMABLE AND HIGHLY EXPLOSIVE, WHICH COULD RESULT IN DEATH OR SERIOUS INJURY.

NOTICE

THE ECM MUST HAVE THE CORRECT CALIBRATION, FAILURE TO HAVE THE PROPER CALIBRATION IN THE ECM CAN RESULT IN SEVERE ENGINE DAMAGE.

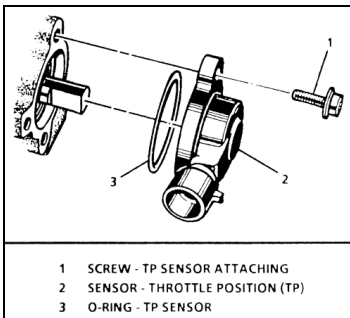

The throttle position sensor (TPS), is used to monitor the position of the throttle butterfly valve.

INSTALLATION

1. Refer to your owner's manual to locate and remove the main fuse.
2. Refer to the service manual for your motorcycle for removal/installation of the throttle body throttle position sensor replacement. .
3. Refer to the owner's manual to install the main fuse.
4. Recalibrate the ECM if needed prior to starting the vehicle.

IMPORTANT NOTICE:

Damage to Feuling® products from incorrect installation, calibration and or from excessive pinion shaft run out and or valve spring coil bind will void manufacturer's warranty.

WARRANTY:

All parts are guaranteed to the original purchaser to be free of manufacturing defects in materials and workmanship for a period of twelve (12) months from the date of purchase. Merchandise that fails to conform to these conditions will be repaired or replaced at FOP's option if the parts are returned to FOP by the purchaser within the (12) month warranty period. In the event warranty service is required, the original purchaser must notify FOP of the problem immediately. Some problems may be rectified by a telephone call and need no further action. A part that is suspect of being defective must not be replaced without prior authorization from FOP. If it is deemed necessary for FOP to make an evaluation to determine whether the part was defective, it must be packaged properly to avoid further damage, and be returned prepaid to FOP with a copy of the original invoice of purchase and a detailed letter outlining the nature of the problem, how the part was used and the circumstances at the time of failure. After an evaluation has been made by FOP and the part was found to be defective, repair, replacement or refund will be granted.

ADDITIONAL WARRANTY PROVISIONS:

FOP shall have no obligation in the event an FOP part is modified by any other person or organization, or if another manufacturer's part is substituted for one provided by FOP. FOP shall have no obligation if an FOP part becomes defective in whole or in part as a result of improper installation, improper break-in or maintenance, improper use, abnormal operation, or any other misuse or mistreatment. FOP shall not be liable for any consequential or incidental damages resulting from the failure of an FOP part, the breach of any warranties, the failure to deliver, delay in delivery, delivery in non-conforming condition, or any other breach of contract or duty between FOP and the customer. The installation of parts may void or otherwise adversely affect your factory warranty. In addition, such installation and use may violate certain federal, state and local laws, rules and ordinances as well as other laws when used on motor vehicles operated on public highways, especially in states where pollution laws may apply. Always check with federal, state, and local laws before modifying your motorcycle. It is the sole and exclusive responsibility of the user to determine the suitability of the product for his/her use, and the user shall assume all legal, personal injury risk and liability and all other obligations, duties and risks associated therewith. Our high performance parts, engines and motorcycles are intended for experienced riders only. Feuling Oil Pump Corporation reserves the right to change prices and/or discounts without notice and to bill at the prevailing prices at the time of shipments.

The words Harley®, Harley-Davidson® and H-D® and all H-D® part numbers and model designations are used in reference only. Feuling Oil Pump Corporation is in no way associated with, or authorized by Harley-Davidson Motor Co®. to manufacture and sell any of the engine parts described in this instruction sheet.

Find out more about air intake & filters we have.