

Instructions: PMB-01-5206

Electronic versions of these instructions and cut templates are available on our website.

1. This installation requires cutting the fender and air box/number plate. If you do not feel that you can safely cut the required plastic parts, have your dealer install the rack for you. Cut templates are included as a reference but addition trimming may be required to achieve a perfect fit. Double back foam tape may be used to help keep debris out of the trimmed plastic areas.

Here are a few techniques that can be used to make the necessary cuts:

- Heat a utility knife with a heat gun or propane torch and cut the plastic with the hot knife.
- Drill a hole or a series of holes in the plastic and then use a knife to trim out the remaining material
- Use a rotary tool with a high speed cutting insert.

2. We recommend using a removable thread locking agent on all bolts in this installation.
3. Remove the seat and side panels.
4. Remove the battery.
5. Disconnect the battery bracket from the fender; there are four bolts on the bottom side of the rear fender.
6. Remove the rear fender. There are six bolts to remove. Remove wiring connectors from lower electrical bracket.
7. Cut out the three plastic cut templates. Check that the template was printed to the correct scale by measuring the one inch square.
8. Line up template A on the bottom left side of the rear fender. Line up the small hole of the template with the small hole in the fender and the curved side of the template with the curves edges on the fender (Picture 1). Cut away cross hatched area of template from the fender.
9. Line up template B on the bottom right side of the rear fender. Line up larger circle with the fender mounting hole and the curved edge of the template with the outside edge of the fender (picture 2). Cut away the square cross hatched area of the template from the fender.
10. Line up template C on the corner of the rib located on the underside of the left side panel (picture 3). Cut away the square cross hatched area of the template from the side panel rib.
11. Install bracket B (item 2) on the inside of the left sub frame rail. Install bracket C (item 4) on the inside of the right sub frame rail (picture 4).
12. Reinstall and wiring connectors to the lower electrical bracket on the rear fender. Reinstall rear fender using the four bolts on the underside of the fender.
13. Install bracket A (item 1) to the outside of the left sub frame rail using three M6 bolts (item 8) into bracket B (item 2) and one M6 bolt (item 11) into the rear fender mounting hole.
14. Reattach the battery bracket to the rear fender.
15. Reinstall the battery.
16. Remove the upper muffler bolt.

ITEM #	PART #	DESCRIPTION	QTY
1	01-5206-BRKT_A_revA	CARGO RACK SUBFRAME BRACKET LEFT	1
2	01-5206-BRKT_B_revA	CARGO RACK SUBFRAME CLAMP LEFT	1
3	01-5206-ARM_L_revA	CARGO RACK ARM LEFT	1
4	01-5206-BRKT_C_revA	CARGO RACK SUBFRAME CLAMP RIGHT	1
5	01-5206-BRKT_D_revA	CARGO RACK SUBFRAME BRACKET RIGHT	1
6	01-5206-ARM_R_revA	CARGO RACK ARM RIGHT	1
7	01-5206-TOP_revA	CARGO RACK TOP	1
8	70-2625	BOLT M6X25 SOCKET S/S	3
9	70-2630	BOLT M6X30 SOCKET S/S	2
10	70-1830	BOLT M8X30 BUTTON S/S	1
11	70-2616	BOLT M6X16 SOCKET S/S	1
12	70-1840	BOLT M8X40 BUTTON S/S	1
13	70-3616	BOLT M6X16 FLAT S/S	4

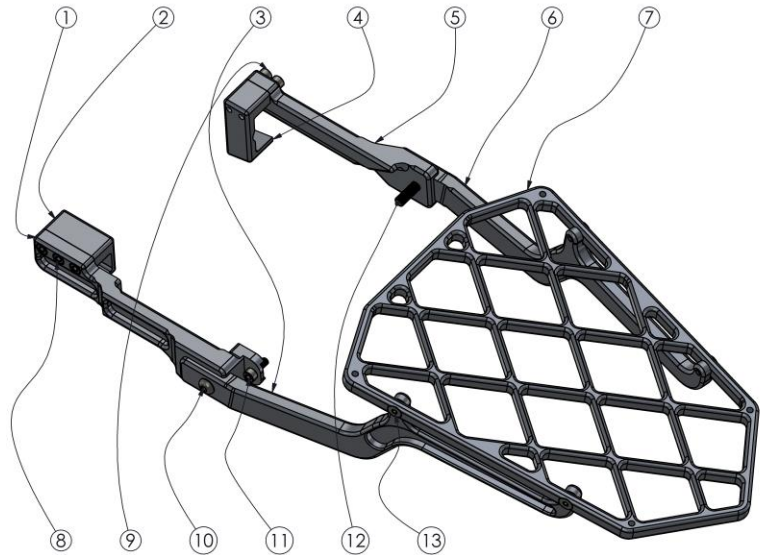

17. Install bracket D (item 5) to the outside of the right sub frame rail using two M6 bolts (item 9) into bracket C (item 4). Be sure the upper muffler bolt hole is aligned with the hole in bracket D (picture 5).
18. Install arm R (item 6) into bracket D (item 5) using one M8 bolt (item 12) into the upper muffler bolt hole.
19. Install arm L (item 3) into bracket A (item 1) using one M8 bolt (item 10).
20. Reinstall side panels and seat.
21. Install rack top (item 7) onto the arms (items 3&6) using four M6 bolts (item 13) (picture 6).
22. Your installation is now complete! After a short ride, check that all fasteners are still tight.

Picture 1

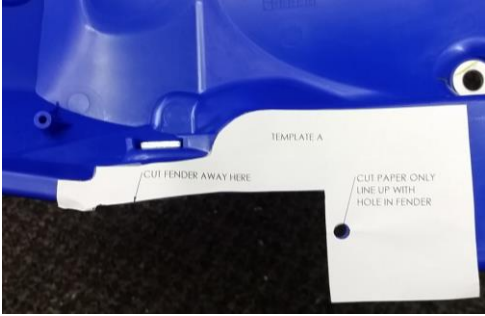

Picture 2



Picture 3



Picture 4



Picture 5



Picture 6



PMB-01-5206 CUT TEMPLATE

TEMPLATE A

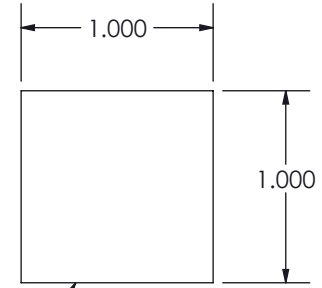
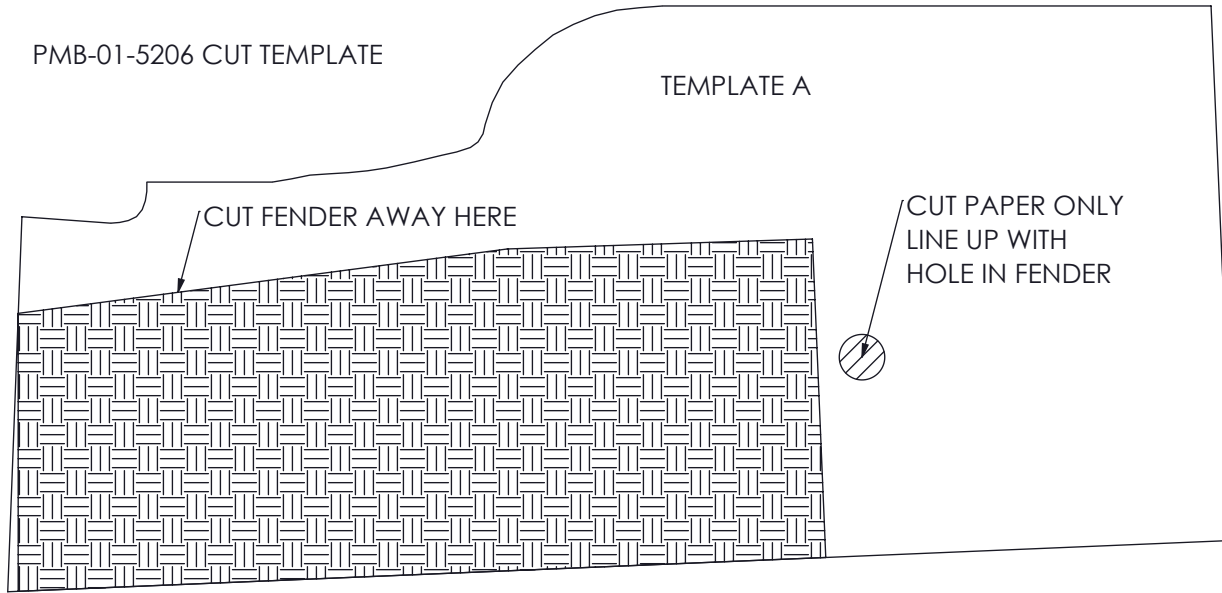

CHECK SCALING BY
MEASURING
1 INCH SQUARE

