

Instructions: ASS-FC-0508

1. Place the bike on a stand and secure it to prevent it from falling over during the installation procedure.
2. **A small amount of semi-permanent thread locking fluid (Blue Loctite #243 or equivalent) should be applied to all fasteners included with stabilizer kit. After a short test ride, check that all bolts are still tight.**

ITEM NO.	PART NUMBER	DESCRIPTION	QTY.
1	LK-CL237_revA	Frame Clamp	1
2	70-2620	BM6 x 20mm Bolt	2
3	LK-PL005_revA	Transfer Arm	1
4	VC1-10,9-M5-0,8-25-BLZ	M5 x 25mm bolt	1
5	LK-SP090_revA	Aluminum Pin Spacer	1
6a	LK-MS130_revA	Frame Clamp Tower (Underbar)	1
7a	LK-PN011_revC	Tower Pin (Underbar)	1
6b	LK-MS140	Frame Clamp Tower (Overbar)	1
7b	LK-PN012_revC	Tower Pin (Overbar)	1

3. Slide the transfer arm (Item 3) onto the stabilizer. The arm should fit snugly onto the stabilizer. **DO NOT** hammer the arm onto the stabilizer. If necessary, rock the arm back and forth into place. Secure the transfer arm to the stabilizer using the M5 bolt (Item 4).

4. Remove the number plate and set it aside.

5. **Underbar Mount Only:** Remove the 2 nuts under the triple-clamp that hold the handlebar clamps. (Figure 1)

6. Remove the top handlebar clamps and lay the handlebars on the front fender. (Figure 2)

7. Slide the back half of the frame clamp (Item 1) on to the frame. (Figure 3) It may be necessary to remove the bolt securing the fuel tank tab to the frame and the 4 bolts attaching the plastics to the fuel tank so the tank can be moved out of the way. After the frame clamp is in place, replace the fuel tank bolts.

8. Slide the front half of the frame clamp onto the frame.

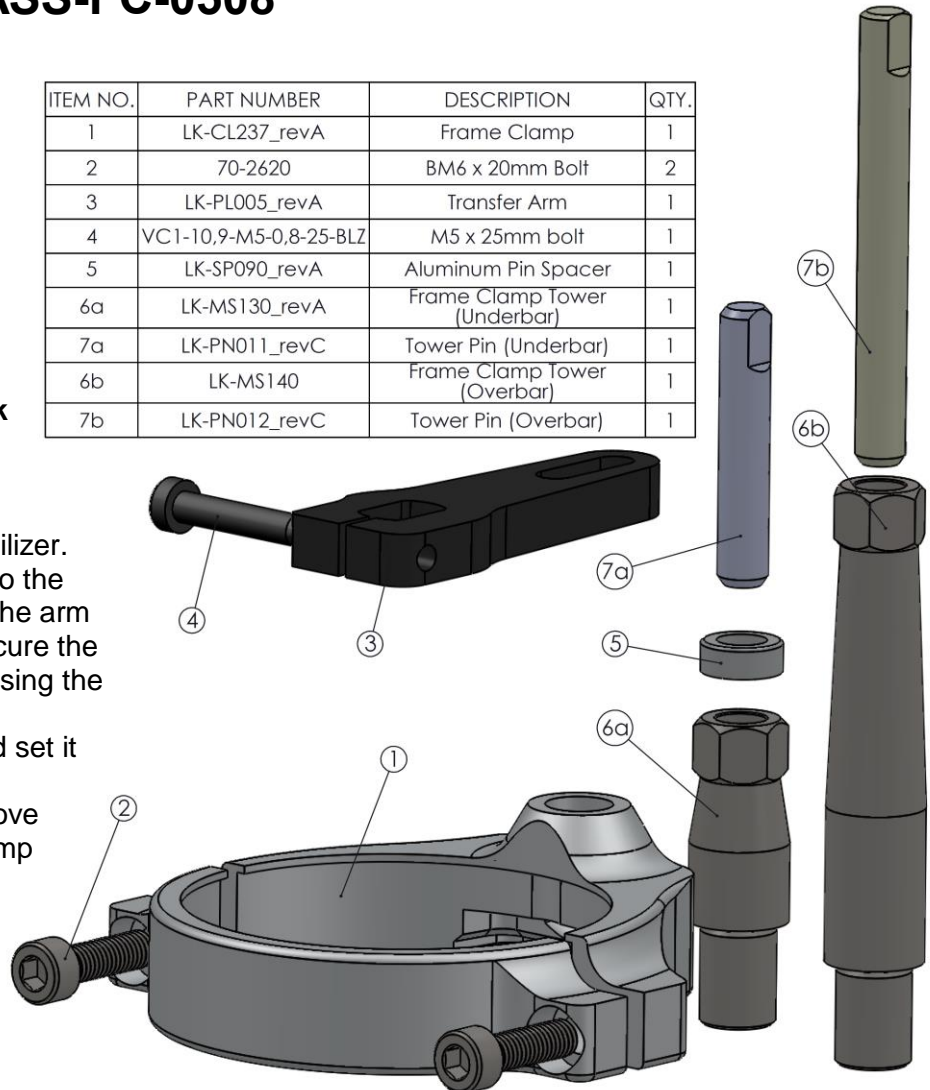

Figure 1: UNDERBAR MOUNT ONLY



Figure 2



Figure 3

9. Secure the two halves of the frame clamp using the two included M6 bolts (Item 2). (Figure 4) Make sure the frame clamp is centered on the frame.
10. Thread the frame clamp tower (Item 6) into the frame clamp and tighten.
11. Apply a light coat of grease to the tower pin (Item 7) and slide it into the frame clamp tower. Grease should also be applied to top of tower pin where it inserts into the transfer arm.
The aluminum spacer (Item 5) on the tower pin is adjustable! Gently tap on the top of the pin with a hammer to adjust height. The top of the tower pin should be flush with the top of the transfer arm. (Figures 5 & 6)

Underbar Stabilizer Installation:

Stop here and refer to instructions included with underbar mount for reassembly.

Overbar Stabilizer Installation:

Follow remaining steps.

12. Install handlebars and overbar mount. Make sure to maintain an even gap between the overbar mount and the handlebar risers when tightening bolts.
13. The overbar mount includes a sliding plate. Adjust the sliding plate so that the stabilizer knobs are centered over the center nut on the triple clamp. Set the stabilizer onto the mount with the tower pin in the slot on the transfer arm and secure the stabilizer to the mount with the 2 M6 bolts included with the stabilizer.
14. **Turn the handle bars both directions and verify that the bars turn to the steering stops. If not, remove the stabilizer from the overbar mount and move the sliding plate forward about 1/8". Reinstall the stabilizer and re-check the steering movement. Repeat if necessary until the handlebar turns to the steering stops in both directions.**



Figure 4



Figure 5



Figure 6