

Instructions: ASS-FC-0202

**Note: Some models may need the forks adjusted to allow for manufacture's recommendation on the distance from the top tripple clamp to the top of the fork tubes.**

1. Place the bike on a stand and secure it to prevent it from falling over during the installation procedure.
2. **A small amount of semi-permanent thread locking fluid (Blue Loctite #243 or equivalent) should be applied to all fasteners included with stabilizer kit. After a short test ride, check that all bolts are still tight.**
3. Slide the transfer arm (Item 3) onto the stabilizer. The arm should fit snugly onto the stabilizer. **DO NOT** hammer the arm onto the stabilizer. If necessary, rock the arm back and forth into place. Secure the transfer arm to the stabilizer using the M5 bolt (Item 4).
4. Remove the number plate and set it aside.
5. Remove the top handlebar clamps and lay the handlebars on the front fender.
6. Remove triple-clamp by loosening the two pinch bolts on each side and removing the center nut.
7. **Underbar Mount Only:** Remove the 2 bolts under the triple-clamp that hold the handlebar clamps.
8. Remove the fuel tank tab bolt and the plastic radiator shrouds.
9. Attach the frame clamp tab (Item 2) to the frame clamp (Item 1) using the M5x8mm bolts (Item 8)
10. Gently spread the frame clamp by sliding a flat screwdriver into the slot at the front of the clamp. With the clamp spread apart, slide it down onto the frame. Ensure that the frame clamp is fully seated on the frame. (Figure 1)
11. Reinstall the fuel tank tab bolt. Secure the frame clamp using the M6 bolt (Item 7). Ensure that the frame clamp does not slide up on the frame when tightening.
12. Slide the triple clamp spacer (Item 6) over the steering stem.(Figure 2)
13. Thread the frame clamp tower (Item 9) into the frame clamp and tighten Don't forget to use thread locking fluid on the tower threads.
14. Reinstall the plastic radiator shrouds.

Item #	PART #	DESCRIPTION	QTY
1	LK-CL193_revA	Frame mount clamp	1
2	LK-CL193-TAB_revA	Frame Clamp Tab	1
3	LK-PL005_revB	Control arm 71mm	1
4	VC1-10,9-M5-0,8-25-BLZ	M5 bolt, 25mm long (1")	1
5	LK-SP090_revA	Aluminum Pin Spacer	1
6	LK-SP124_revA	Triple Clamp Spacer	1
7	70-2625	BOLT M6X25 SOCKET S/S	1
8	70-1508	BOLT M5X8 BUTTON S/S	2
9a	LK-MS033_revB	Frame Clamp Tower (Underbar)	1
9b	LK-MS040_revB	Frame Clamp Tower (Overbar)	1
10a	LK-PN011_revC	Tower Pin (Underbar)	1
10b	LK-PN012_revC	Tower Pin (Overbar)	1

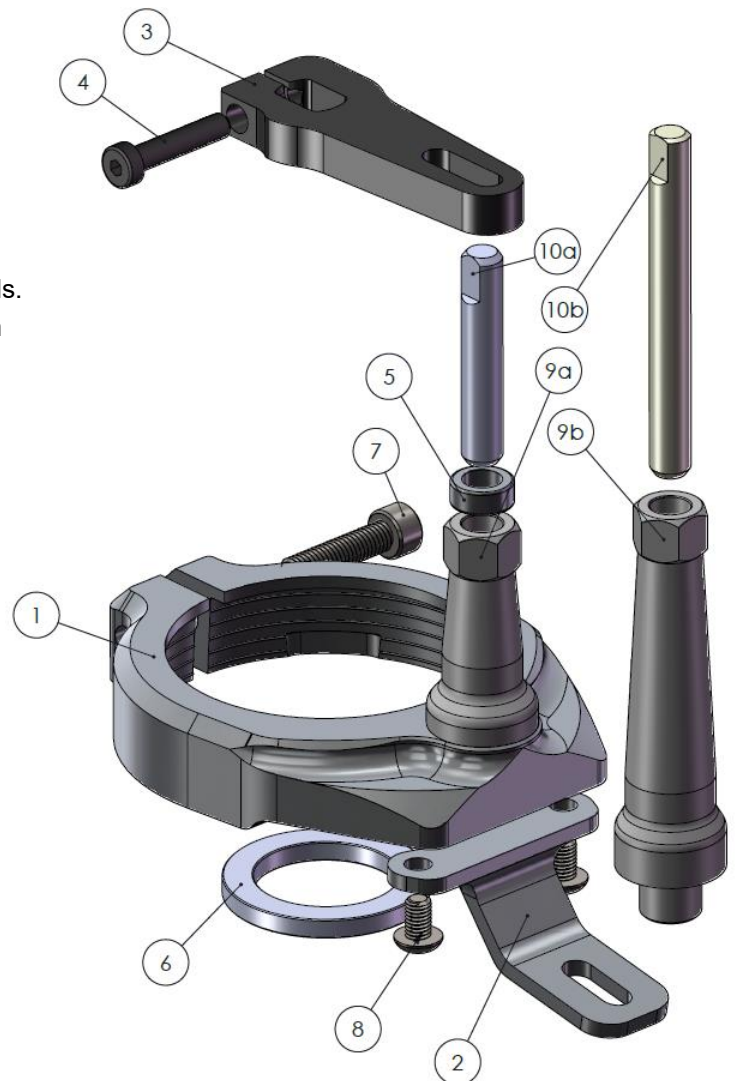



Figure 1



Figure 2

15. Apply a light coat of grease to the tower pin (Item 10) and slide it into the frame clamp tower. Grease should also be applied to top of tower pin where it inserts into the transfer arm. The aluminum spacer (Item 5) on the tower pin is adjustable! Gently tap on the top of the pin with a hammer to adjust height. The top of the tower pin should be flush with the top of the transfer arm. (Figures 3 & 4)

**Underbar Stabilizer Installation:**

Stop here and refer to instructions included with underbar mount for reassembly.

**Overbar Stabilizer**

**Installation:** Follow remaining steps.

16. Reinstall triple-clamp, leave off stock washer between triple clamp and center nut; torque the center nut to factory specifications and then torque pinch bolts to factory specifications.
17. Install handlebars and overbar mount. Make sure to maintain an even gap between the overbar mount and the handlebar risers when tightening bolts.
18. The overbar mount includes a sliding plate. Adjust the sliding plate so that the stabilizer knobs are centered over the center nut on the triple clamp. Set the stabilizer onto the mount with the tower pin in the slot on the transfer arm and secure the stabilizer to the mount with the two M6 bolts included with the stabilizer.
19. **Turn the handlebars both directions and verify that the bars turn to the steering stops. If not, remove the stabilizer from the overbar mount and move the sliding plate forward about 1/8". Reinstall the stabilizer and re-check the steering movement. Repeat if necessary until the handlebar turns to the steering stops in both directions.**
20. Installation is now complete. Check the tightness of bolts regularly and enjoy your new Fastway steering stabilizer!



Figure 3



Figure 4