

Instructions: ASS-FC-0105

NOTE: A small amount of semi-permanent thread locking fluid (Blue Loctite #243 or equivalent) should be applied to all fasteners included with stabilizer kit.

After a short test ride, check that all bolts are still tight.

1. Place the bike on a stand and secure it to prevent it from falling over during the installation procedure.
2. Slide the transfer arm (Item 3) onto the stabilizer. The arm should fit snugly onto the stabilizer. DO NOT hammer the arm onto the stabilizer. If necessary, rock the arm back and forth into place. Secure the transfer arm to the stabilizer using the M5 bolt (Item 2). Torque to 8 ft-lbs (11 Nm).
3. If applicable, remove the computer attached to the triple clamp and reinstall it using the two M6 bolts (item 10) and two spacers (item 11) between the computer bracket and triple clamp.
4. Inspect the stamped metal dust seal below the triple clamps. Use a small file to remove any lips or burrs from the dust seal.
5. Slide the front half of the frame clamp (Item 4) around the frame and into place. It may be easier to remove the number plate, but it is not necessary (Figure 1).
6. Slide the back half of the frame clamp (Item 4) onto the frame. It may be necessary to hit any high spots in the head tube weld with a file to achieve a quality fit (Figure 2). If preferred, use a rotary tool to remove material from the frame clamp in the area of weld irregularities.
7. Bolt the two halves of the frame clamp together using the two included M6 bolts (Item 1). Tighten bolts evenly. Torque to 12 ft-lbs (16 Nm). (Figure 3)
8. Thread the frame clamp tower (Item 6) into the frame clamp and tighten to 40 ft-lbs (54 Nm). (Figure 4)
9. Apply a light coat of grease to the tower pin (Item 7) and slide it into the frame clamp tower. Grease should also be applied to top of tower pin where it inserts into the transfer arm.
10. **The aluminum spacer (Item 5) on the tower pin is adjustable!** Gently tap on the top of the pin with a hammer to adjust height. The top of the tower pin should be flush with the top of the transfer arm (Figures 5 & 6).

ITEM NO.	PART NUMBER	DESCRIPTION	QTY.
1	70-2625	BOLT M6X25 SOCKET S/S	2
2	VC1-10,9-M5-0,8-25-BLZ	M5 bolt, 25mm long (1")	1
3	LK-PL129_revA	Control arm (DS)	1
4	LK-CL076_revG	Frame Mount Clamp	1
5	LK-SP090_revA	Aluminum Pin Spacer	2
6a	LK-MS030_revE	Frame Clamp Tower (Underbar)	1
7a	LK-PN011_revC	Tower Pin (Underbar)	1
6b	LK-MS040_revB	Frame Clamp Tower (Overbar)	1
7b	LK-PN012_revC	Tower Pin (Overbar)	1
10	70-2630	BOLT M6X30 SOCKET S/S	2
11	70-7001	SPACER 6X16X9 ALUMINUM	2

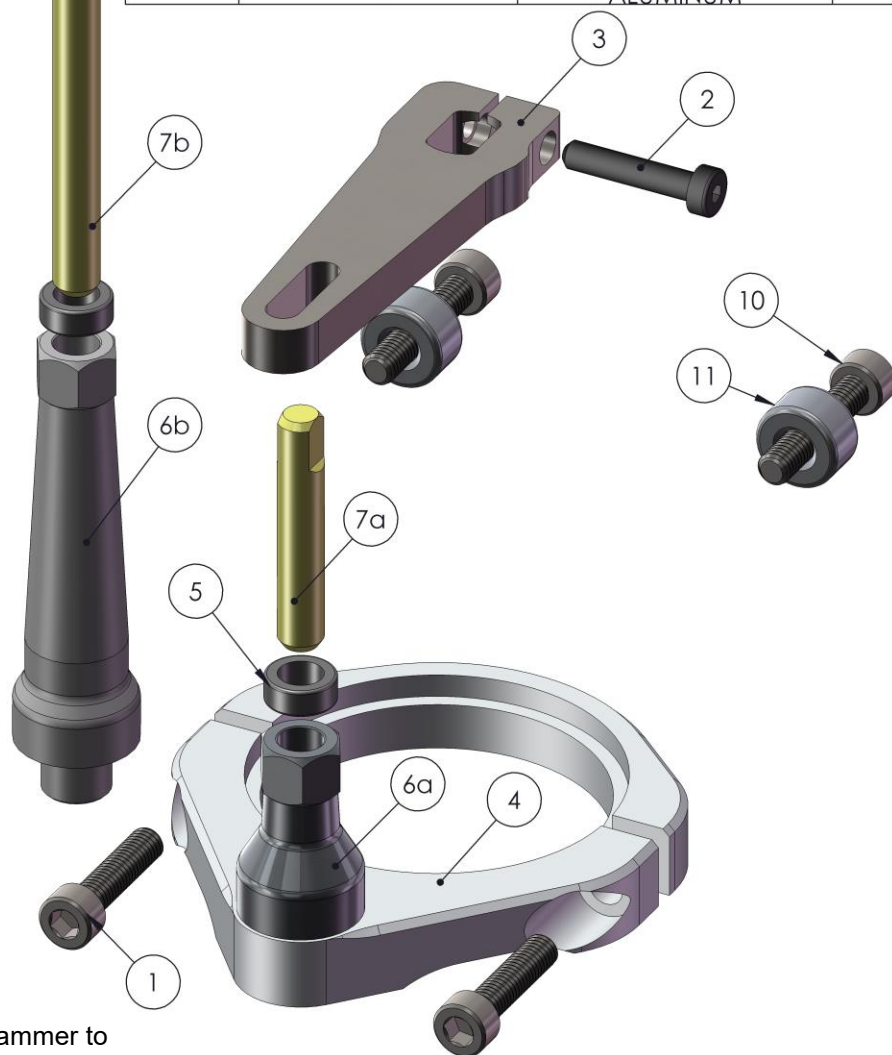



Figure 1



Figure 2



Figure 3

Underbar Stabilizer Installation:

Stop here and refer to instructions included with underbar mount.

Overbar Stabilizer Installation:

Follow remaining steps.

11. Install handlebars and overbar mount. Make sure to maintain an even gap between the overbar mount and the handlebar risers when tightening bolts. Torque all four bolts evenly to 25 ft-lbs (34 Nm) using an "X" pattern.
12. The overbar mount includes a sliding plate. Adjust the sliding plate so that the stabilizer knobs are centered over the center nut on the triple clamp. Torque the sliding plate bolts to 8 ft-lbs (11 Nm). Set the stabilizer onto the mount with the tower pin in the slot on the transfer arm and secure the stabilizer to the mount with the 2 M6 bolts included with the stabilizer. Torque both bolts to 12 ft-lbs (16 Nm).
13. **Turn the handle bars in both directions and verify that the bars turn to the steering stops. If not, remove the stabilizer from the overbar mount and move the sliding plate forward about 1/8". Reinstall the stabilizer and re-check the steering movement. Repeat if necessary until the handlebar turns to the steering stops in both directions.**



Figure 4



Figure 5



Figure 6