

Instructions: ASS-DM-0501

1. Install frame clamp using frame clamp instructions.
2. **A small amount of semi-permanent thread locking fluid (Blue Loctite #243 or equivalent) should be applied to all fasteners.**
3. Remove the stock handlebar risers from the triple-clamp.
4. Place the stabilizer mount (Item 4) on the triple-clamp.
5. Set the stabilizer on the mount and check that the transfer arm clears the center nut on the triple clamp. If not, place the 6mm spacers (Item 8) under the stabilizer mount.
6. Insert the M10 bolts from the underside of triple-clamp. Use the longer M10 bolts (Item 9) and washers (Item 1) if the spacers were placed under the stabilizer mount. Otherwise use the shorter M10 bolts (Item 7) and washers.
7. Set the handlebar clamps (Items 2&3) onto the stabilizer mount. The handlebar risers are reversible to allow for two handlebar positions (arrows pointing forward = forward handlebar offset). Remove the riser and move it to the other side to change offset.
8. Place the stabilizer on the stabilizer mount with the transfer arm to the side of the tower pin. Make sure the height of the tower pin is adjusted so that the top of the pin is flush with the top of the transfer arm. **See frame clamp instructions for details.** (Figure 1)
9. Install the stabilizer on the underbar mount using the M6 bolts included with the stabilizer.
10. Install handlebars and top clamps (Item 6) using the M8 bolts (Item 5). Make sure to maintain an even gap between the overbar mount and the handlebar risers when tightening bolts. (Figure 2)

ITEM NO.	PART NUMBER	DESCRIPTION	QTY.
1	LK-CL234	Handlebar Clamp	1
2	LK-CL235	Handlebar Clamp	1
3	LK-PL079_revB	Underbar Stabilizer Mount	1
4	LK-CL232_revB	Handlebar Top Clamp	2
5	LK-SP125_revX	6mm Spacer	2
6	VA1-12.9-M10-1,5-75	M10 x 75mm Bolt	1
7	RA6-M10,5-M20-2	M10 bolt washer	2
8	70-2825	BOLT M8x25 SOCKET S/S	4
9	VA1-12.9-M10-1,5-80	M10x80 Socket Head Cap Screw	2

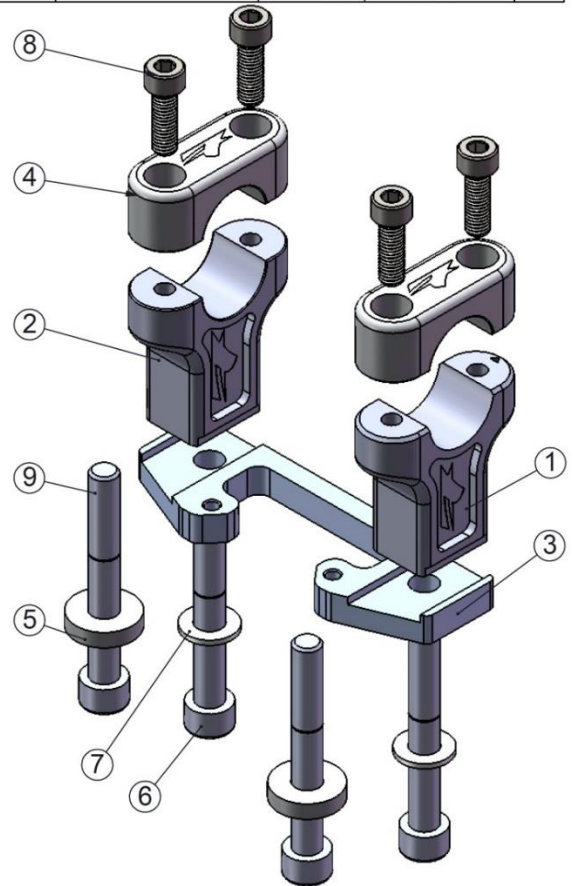

Figure 1



Figure 2