

Instructions: ASS-DM-0108

1. Install frame clamp using the frame clamp instructions.
2. A small amount of semi-permanent thread locking fluid (Blue Loctite #243 or equivalent) should be applied to all fasteners.
3. Remove the handlebar top clamps, handlebars, and stock handlebar risers.
4. Set the underbar stabilizer mount (Item 4) on the triple clamp. The holes in the mount should match the two sets of tapped holes in the triple clamp.
5. Install the handlebar risers (Items 5 & 6) in a position to suit the rider's preference. The risers are offset so that switching the left and right risers will offset the handlebars 4mm.
6. Attach the handlebar risers with the two M10 bolts (Item 2) and torque to 40Nm (29.5 lbf ft). (Figure 1)
7. Install handlebars and handlebar top clamps (Item 1) using the M8 bolts (Item 3). The gap between the handlebar top clamps and the handlebar risers should be equal from front to back when tightening bolts.
8. Install the stabilizer on the underbar mount. Make sure the height of the tower pin is adjusted so that the top of the pin is flush with the top of the transfer arm. **See frame clamp instructions for details.** (Figure 2)

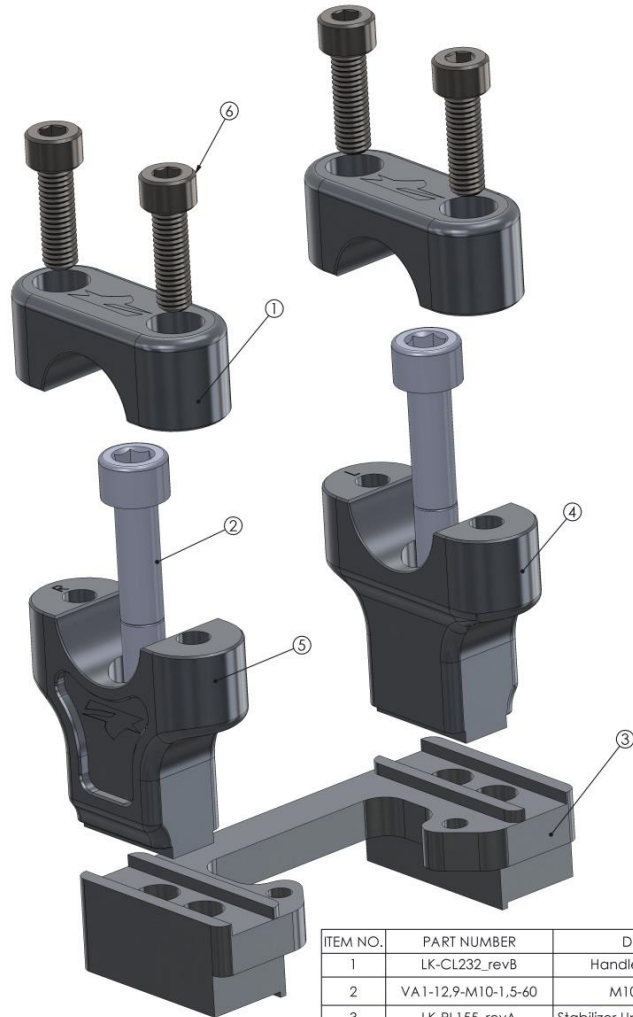

ITEM NO.	PART NUMBER	DESCRIPTION	QTY.
1	LK-CL232_revB	Handlebar Top Clamp	2
2	VA1-12,9-M10-1,5-60	M10 x 60mm Bolt	2
3	LK-PL155_revA	Stabilizer Under-bar Mount Plate	1
4	LK-CL230L_revB	UNDERBAR RISER	1
5	LK-CL230R_revB	UNDERBAR RISER	1
6	70-2825	BOLT M8x25 SOCKET S/S	4



Figure 1



Figure 2