

Instructions: 22-14-0001

1. Place the bike on a stand and secure it to prevent it from falling over during the installation procedure.
2. A small amount of semi-permanent thread locking fluid (Blue Loctite #243 or equivalent) should be applied to all fasteners.
3. If not already removed, remove the handlebar top clamps, handlebars, and stock handlebar risers (Figure 1). Retain the two stock M10 bolts that fasten the handlebar risers to the triple clamp.
4. Install the handlebar bottom clamp (Item 3) in a position to suit the rider's preference (Forward or backward offset). Utilize the stock M10 bolts to attach the bottom clamp. Torque the M10 bolts to factory specifications.
5. Install handlebar and handlebar top clamp (Item 2) using the M8 bolts (Item 1). The gap between the handlebar top clamps and the handlebar risers should be equal from front to back when tightening bolts. (Figure 2)

ITEM #	PART #	DESCRIPTION	QTY
1	70-2825	BOLT M8x25 SOCKET S/S	4
2	LK-CL263_revA	TOP CLAMP	1
3	LK-CL264_revA	BOTTOM CLAMP	1

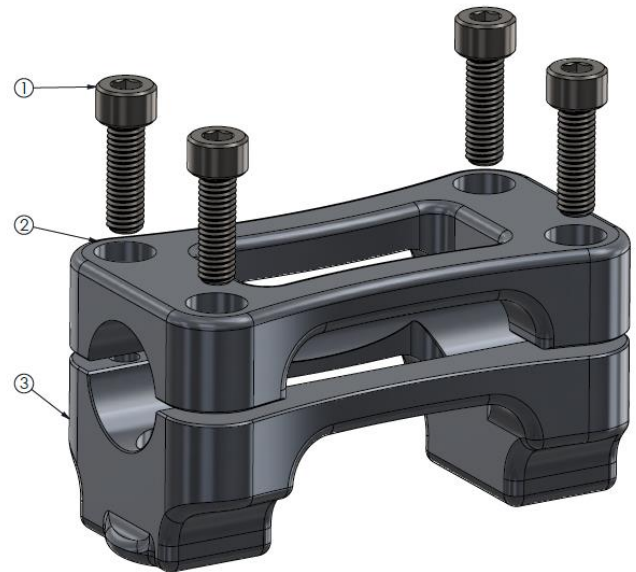

Figure 1. Depicts the stock handlebar riser and top clamp assembly.



Figure 2. Depicts the Fastway handlebar clamp installed.

Note: Some reference pictures are taken during initial prototyping and may not reflect the final color of certain components